

SERVICE MANUAL

AA-2D CHASSIS

<u>MODEL</u>	<u>COMMANDER</u>	<u>DEST.</u>	<u>CHASSIS NO.</u>
KV-32V26	RM-Y137A	US	SCC-K96B-A
KV-32V26	RM-Y137A	CND	SCC-K97A-A
KV-32V36	RM-Y137A	US	SCC-K96C-A
KV-32V36	RM-Y137A	CND	SCC-K97B-A
KV-34V36C	RM-Y137A	E	SCC-K98A-A
KV-35V36	RM-Y137A	US	SCC-K96G-A
KV-35V36	RM-Y137A	CND	SCC-K97F-A
KV-35V76	RM-Y137A	US	SCC-K96H-A
KV-37V36M	RM-Y137A	E	SCC-K98J-A

Note: Adjustment Manual for this model is published separately

	Adjustment Manual
Part No.	9-965-829-01

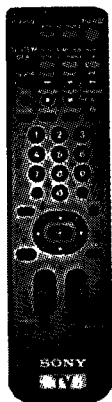

RM-Y137A



KV-32V36

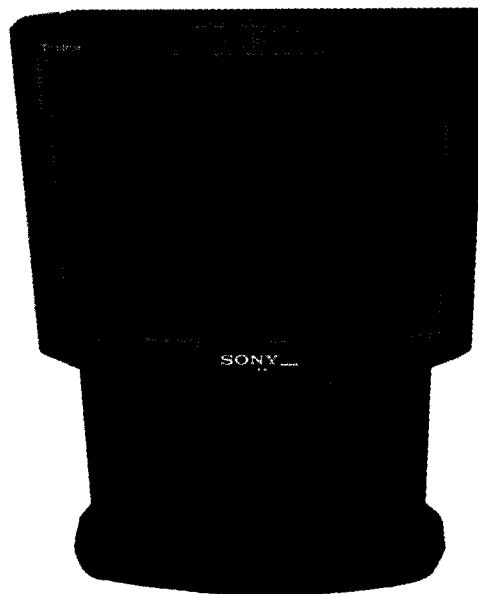

KV-35V76



996582701

TRINITRON® COLOR TV
SONY®

SPECIFICATIONS

For all models:

Television system	American TV standard
Channel coverage	VHF : 2-13 UHF : 14-69 CATV : 1-125
Antenna	75-ohm external antenna terminal for VHF / UHF
Picture tube	Hi-Black Trinitron® tube

For specific models:

	KV-32V26	KV-32V36	KV-34V36C	KV-35V36	KV-35V76	KV-37V36M
Screen Size (measured diagonally)	32 inch	32 inch	32 inch	35 inch	35 inch	35 inch
Power requirements	120V, 60Hz	120V, 60Hz	220V, 50/60Hz	120V, 60Hz	120V, 60Hz	120V, 60Hz
Number of inputs/outputs						
Video ⁽¹⁾	3	3	3	3	3	3
S video ⁽²⁾	1	2	2	2	2	2
Audio ⁽³⁾	3	3	3	3	3	3
Audio out ⁽⁴⁾	1	1	1	1	1	1
Monitor out ⁽¹⁾	1	1	1	1	1	1
TV out ⁽¹⁾	-	1	1	1	1	1
S-Link	●	●	●	●	●	●
Speaker output (W)	5W x 2	10W x 2	10W x 2	5W x 2	10W x 2	5W x 2
Power consumption (W) When in use (Max.) In Standby	190W 13W	210W, 2.75A 13W	210W 13W	215W, 2.80A 13W	225W, 2.90A 13W	215W, 2.80A 13W
Dimensions (W/H/D) (mm)	821 x 675.3 x 587 mm	821 x 675.3 x 587 mm	821 x 675.3 x 587 mm	920 x 730.8 x 641.8 mm	920 x 1207 x 713 mm	920 x 730.8 x 641.8 mm
(in.)	33 ¹ / ₂ x 27 ⁵ / ₈ x 24 in.	33 ¹ / ₂ x 27 ⁵ / ₈ x 24 in.	33 ¹ / ₂ x 27 ⁵ / ₈ x 24 in.	37 ⁵ / ₈ x 29 ⁷ / ₈ x 26 ¹ / ₈ in	37 ⁵ / ₈ x 49 ³ / ₈ x 28 ¹ / ₈ in	37 ⁵ / ₈ x 29 ⁷ / ₈ x 26 ¹ / ₈ in
Mass (kg) (lb)	70 kg 154 lbs 6oz	70 kg 154 lbs 6oz	70 kg 154 lbs 6oz	90 kg 198 lbs 7oz	130 kg 279 lbs 6oz	90 kg 198 lbs 7oz
Supplied accessories Remote commander (w/ 2 size AA (R6) batteries)	RM-Y137A	RM-Y137A	RM-Y137A	RM-Y137A	RM-Y137A	RM-Y137A

⁽¹⁾ 1 Vp-p, 75 ohms unbalanced, sync negative

⁽²⁾ Y: 1 Vp-p, 75 ohms unbalanced, sync negative C: 0.286 Vp-p (Burst signal), 75 ohms

⁽³⁾ 500 mVrms (100% modulation); Impedance: 47 kilohms

⁽⁴⁾ More than 408 mVrms at the maximum volume setting (variable)

More than 408mVrms (fix); Impedance: 5 kilohms

**** Design and specifications are subject to change without notice.**

Optional accessories

Connecting cables VMC-810S/820S, VMC-720M,
YC-15V/30V, RK-74A
TV Stand SU-32A (KV-32V26/32V36/34V36C only)
TV Stand SU-35A (KV-35V36/37V36M)
U/V mixer EAC-66

(●)® SRS (SOUND RETRIEVAL SYSTEM)

The (●) SRS (SOUND RETRIEVAL SYSTEM) is manufactured by Sony Corporation under license from SRS Labs, Inc. It is covered by U.S. Patent No. 4,748,669. Other U.S. and foreign patents pending.

The word "SRS" and the SRS symbol (●) are registered trademarks of SRS Labs, Inc.

SAFETY CHECK-OUT (US Model only)

After correcting the original service problem, perform the following safety checks before releasing the set to the customer:

1. Check the area of your repair for unsoldered or poorly-soldered connections. Check the entire board surface for solder splashes and bridges.
2. Check the interboard wiring to ensure that no wires are "pinched" or contact high-wattage resistors.
3. Check that all control knobs, shields, covers, ground straps, and mounting hardware have been replaced. Be absolutely certain that you have replaced all the insulators.
4. Look for unauthorized replacement parts, particularly transistors, that were installed during a previous repair. Point them out to the customer and recommend their replacement.
5. Look for parts which, though functioning, show obvious signs of deterioration. Point them out to the customer and recommend their replacement.
6. Check the line cords for cracks and abrasion. Recommend the replacement of any such line cord to the customer.
7. Check the B+ and HV to see if they are specified values. Make sure your instruments are accurate; be suspicious of your HV meter if sets always have low HV.
8. Check the antenna terminals, metal trim, "metallized" knobs, screws, and all other exposed metal parts for AC Leakage. Check leakage as described below.

LEAKAGE TEST

The AC leakage from any exposed metal part to earth ground and from all exposed metal parts to any exposed metal part having a return to chassis, must not exceed 0.5 mA (500 microampere). Leakage current can be measured by any one of three methods.

1. A commercial leakage tester, such as the Simpson 229 or RCA WT-540A. Follow the manufacturers' instructions to use these instructions.
2. A battery-operated AC milliammeter. The Data Precision 245 digital multimeter is suitable for this job.
3. Measuring the voltage drop across a resistor by means of a VOM or battery-operated AC voltmeter. The "limit" indication is 0.75 V, so analog meters must have an accurate low voltage scale. The Simpson's 250 and Sanwa SH-63Trd are examples of passive VOMs that are suitable. Nearly all battery operated digital multimeters that have a 2V AC range are suitable. (See Fig. A)

HOW TO FIND A GOOD EARTH GROUND

A cold-water pipe is guaranteed earth ground; the cover-plate retaining screw on most AC outlet boxes is also at earth ground. If the retaining screw is to be used as your earth-ground, verify that it is at ground by measuring the resistance between it and a cold-water pipe with an ohmmeter. The reading should be zero ohms. If a cold-water pipe is not accessible, connect a 60-100 watts trouble light (not a neon lamp) between the hot side of the receptacle and the retaining screw. Try both slots, if necessary, to locate the hot side of the line, the lamp should light at normal brilliance if the screw is at ground potential. (See Fig. B)

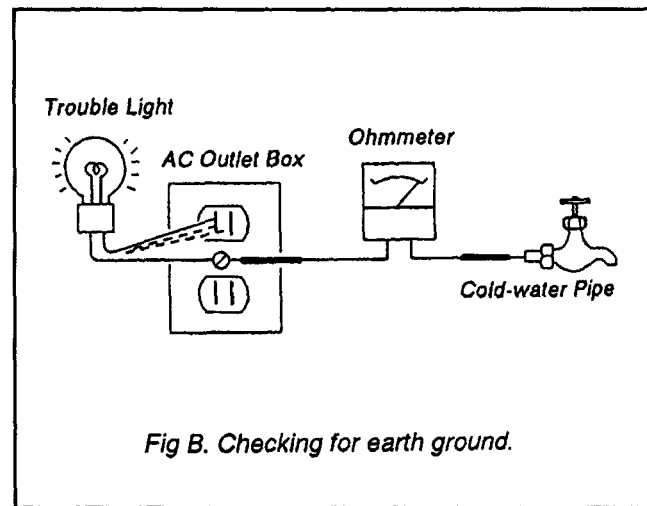
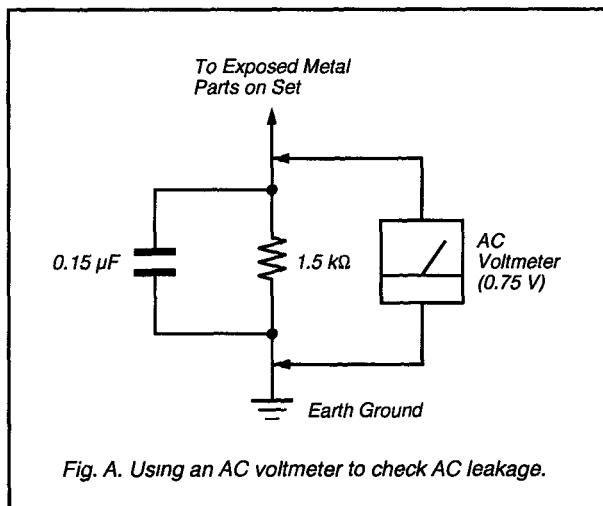

TABLE OF CONTENTS

<u>Section</u>	<u>Title</u>	<u>Page</u>	<u>Section</u>	<u>Title</u>	<u>Page</u>
1. GENERAL			2-3.	Cabinet Base Removal (35V76)	12
Welcome!		5	2-4.	Service Position	13
Connecting and Installing the TV		5	2-5.	Control Switch Removal	13
Connector Types		5	2-6-1.	Picture Tube Removal (32V26/32V36/34V36C)	14
Making Connections		5	2-6-2.	Picture Tube Removal(35V36/35V75/37V36M)	14
Installing the glass door		7	3. SAFETY RELATED ADJUSTMENTS		15
Adjusting the shelf		7	4. DIAGRAMS		
Basic Set up		7	4-1.	Block Diagram	17
Inserting Batteries		7	4-2.	Frame Schematic Diagram	21
Using the remote control/Select buttons		7	4-3.	Circuit Boards Location	25
Adjusting slides		7	4-4.	Printed Wiring Boards and Schematic Diagrams	25
On Line Help/Instructions		7	• P Board		26
Using your New TV		8	• SC Board		29
Setting up the TV automatically		8	• A Board		30
Watching the TV		8	• UV Board		39
Watching two programs at one time - PIP		8	• WA Board		44
Adjusting your SET UP (menus)		9	• HV Board		47
Learning menu selection		9	• WB Board		49
Using the VIDEO menu		9	• C Board		51
Using the AUDIO menu		9	• G Board		53
Using the TIMER menu		10	• AV Board		56
Using the SET UP menu		10	• HS, K Boards		59
Operating Video Equipment		10	4-5.	Semiconductors	61
Setting the manufacturer's code		10	5. EXPLODED VIEWS		
VCR manufacturer code numbers		10	5-1.	Chassis (KV-32V26/32V36/34V36C)	63
MDP manufacturer code numbers		10	5-2.	Picture Tube (KV-32V26/32V36/34V36C)	64
Operating a cable box DBS receiver		11	5-3.	Chassis (KV-35V36/35V76/37V36M)	65
Troubleshooting		11	5-4.	Picture Tube (KV-35V36/35V76/37V36M)	66
2. DISASSEMBLY			5-5.	Cabinet Base (KV-35V76)	67
2-1-1.	Rear Cover and Speaker Removal (32V26/32V36/34V36C)	12	6. ELECTRICAL PARTS LIST		68
2-1-2.	Rear Cover and Speaker Removal (35V36/35V76/37V36M)	12			
2-2.	Chassis Assy Removal	12			

CAUTION!

SHORT CIRCUIT THE ANODE OF THE PICTURE TUBE AND THE ANODE CAP TO THE METAL CHASSIS, CRT SHIELD, OR CARBON PAINTED ON THE CRT, AFTER REMOVING THE ANODE.

ATTENTION

APRES AVOIR DECONNECTE LE CAP DE L'ANODE, COURT-CIRCUITER L'ANODE DU TUBE CATHODIQUE ET CELUI DE L'ANODE DU CAP AU CHASSIS METALLIQUE DE L'APPAREIL, OU AU COUCHE DE CARBON PEINTE SUR LE TUBE CATHODIQUE OU AU BLINDAGE DU TUBE CATHODIQUE.

WARNING!!

AN ISOLATION TRANSFORMER SHOULD BE USED DURING ANY SERVICE TO AVOID POSSIBLE SHOCK HAZARD, BECAUSE OF LIVE CHASSIS. THE CHASSIS OF THIS RECEIVER IS DIRECTLY CONNECTED TO THE AC POWER LINE.

ATTENTION!!

AFIN D'EVITER TOUT RESQUE D'ELECTROCUTION PROVENANT D'UN CHÂSSIS SOUS TENSION, UN TRANSFORMATEUR D'ISOLEMENT DOIT ETRE UTILISÉ LORS DE TOUT DÉPANNAGE. LE CHÂSSIS DE CE RÉCEPTEUR EST DIRECTEMENT RACCORDÉ À L'ALIMENTATION SECTEUR.

SAFETY-RELATED COMPONENT WARNING!!

COMPONENTS IDENTIFIED BY SHADING AND MARK Δ ON THE SCHEMATIC DIAGRAMS, EXPLODED VIEWS AND IN THE PARTS LIST ARE CRITICAL FOR SAFE OPERATION. REPLACE THESE COMPONENTS WITH SONY PARTS WHOSE PART NUMBERS APPEAR AS SHOWN IN THIS MANUAL OR IN SUPPLEMENTS PUBLISHED BY SONY. CIRCUIT ADJUSTMENTS THAT ARE CRITICAL FOR SAFE OPERATION ARE IDENTIFIED IN THIS MANUAL. FOLLOW THESE PROCEDURES WHENEVER CRITICAL COMPONENTS ARE REPLACED OR IMPROPER OPERATION IS SUSPECTED.

ATTENTION AUX COMPOSANTS RELATIFS A LA SECURITE!!
--

LES COMPOSANTS IDENTIFIES PAR UNE TRAME ET PAR UNE MARQUE Δ SUR LES SCHEMAS DE PRINCIPE, LES VUES EXPLOSEES ET LES LISTES DE PIECES SONT D'UNE IMPORTANCE CRITIQUE POUR LA SECURITE DU FONCTIONNEMENT. NE LES REMPLACER QUE PAR DES COMPOSANTS SONY DONT LE NUMERO DE PIECE EST INDIQUE DANS LE PRESENT MANUEL OU DANS DES SUPPLEMENTS PUBLIES PAR SONY. LES REGLAGES DE CIRCUIT DONT L'IMPORTANCE EST CRITIQUE POUR LA SECURITE DU FONCTIONNEMENT SONT IDENTIFIES DANS LE PRESENT MANUEL. SUIVRE CES PROCEDURES LORS DE CHAQUE REMPLACEMENT DE COMPOSANTS CRITIQUES, OU LORSQU'UN MAUVAIS FONCTIONNEMENT SUSPECTE.

SECTION 1 GENERAL

The instructions mentioned here are partial abstracts from the Operating Instruction Manual. The page numbers shown reflect those of the Operating Instruction Manual.

Welcome!

Thank you for purchasing the Sony Trinitron® Color TV. This manual is written for the models listed below. Before reading, check the model number on the rear of your TV.

Model KV-27526 is used for illustration purposes. The screens displayed are for model KV-35V36. Differences in operation features are indicated in the text, for example, "KV-27526 only".

Model Number	Screen Size (inch) (diag.)	Lighting System	TV Connection	Channel No.	Remote Control
KV-27526	27"	•	•	3, 4, 5, 6, 7, 8, 9, 10, 11, 12, 13, 14, 15, 16, 17, 18, 19, 20, 21, 22, 23, 24, 25, 26, 27, 28, 29, 30, 31, 32, 33, 34, 35, 36, 37, 38, 39, 40, 41, 42, 43, 44, 45, 46, 47, 48, 49, 50, 51, 52, 53, 54, 55, 56, 57, 58, 59, 60, 61, 62, 63, 64, 65, 66, 67, 68, 69, 70, 71, 72, 73, 74, 75, 76, 77, 78, 79, 80, 81, 82, 83, 84, 85, 86, 87, 88, 89, 90, 91, 92, 93, 94, 95, 96, 97, 98, 99, 100	•
KV-27526C	27"	•	•	3, 4, 5, 6, 7, 8, 9, 10, 11, 12, 13, 14, 15, 16, 17, 18, 19, 20, 21, 22, 23, 24, 25, 26, 27, 28, 29, 30, 31, 32, 33, 34, 35, 36, 37, 38, 39, 40, 41, 42, 43, 44, 45, 46, 47, 48, 49, 50, 51, 52, 53, 54, 55, 56, 57, 58, 59, 60, 61, 62, 63, 64, 65, 66, 67, 68, 69, 70, 71, 72, 73, 74, 75, 76, 77, 78, 79, 80, 81, 82, 83, 84, 85, 86, 87, 88, 89, 90, 91, 92, 93, 94, 95, 96, 97, 98, 99, 100	•
KV-35V36	35"	•	•	3, 4, 5, 6, 7, 8, 9, 10, 11, 12, 13, 14, 15, 16, 17, 18, 19, 20, 21, 22, 23, 24, 25, 26, 27, 28, 29, 30, 31, 32, 33, 34, 35, 36, 37, 38, 39, 40, 41, 42, 43, 44, 45, 46, 47, 48, 49, 50, 51, 52, 53, 54, 55, 56, 57, 58, 59, 60, 61, 62, 63, 64, 65, 66, 67, 68, 69, 70, 71, 72, 73, 74, 75, 76, 77, 78, 79, 80, 81, 82, 83, 84, 85, 86, 87, 88, 89, 90, 91, 92, 93, 94, 95, 96, 97, 98, 99, 100	•
KV-35V36C	35"	•	•	3, 4, 5, 6, 7, 8, 9, 10, 11, 12, 13, 14, 15, 16, 17, 18, 19, 20, 21, 22, 23, 24, 25, 26, 27, 28, 29, 30, 31, 32, 33, 34, 35, 36, 37, 38, 39, 40, 41, 42, 43, 44, 45, 46, 47, 48, 49, 50, 51, 52, 53, 54, 55, 56, 57, 58, 59, 60, 61, 62, 63, 64, 65, 66, 67, 68, 69, 70, 71, 72, 73, 74, 75, 76, 77, 78, 79, 80, 81, 82, 83, 84, 85, 86, 87, 88, 89, 90, 91, 92, 93, 94, 95, 96, 97, 98, 99, 100	•
KV-37V36M	37"	•	•	3, 4, 5, 6, 7, 8, 9, 10, 11, 12, 13, 14, 15, 16, 17, 18, 19, 20, 21, 22, 23, 24, 25, 26, 27, 28, 29, 30, 31, 32, 33, 34, 35, 36, 37, 38, 39, 40, 41, 42, 43, 44, 45, 46, 47, 48, 49, 50, 51, 52, 53, 54, 55, 56, 57, 58, 59, 60, 61, 62, 63, 64, 65, 66, 67, 68, 69, 70, 71, 72, 73, 74, 75, 76, 77, 78, 79, 80, 81, 82, 83, 84, 85, 86, 87, 88, 89, 90, 91, 92, 93, 94, 95, 96, 97, 98, 99, 100	•

Precautions

Safety

- Operate the TV only on 120 V AC (except KV-29RS26C, 29V36C, 34RS26C, 34V36C).
- Operate the TV only on 220 V AC (KV-29RS26C, 29V36C, 34RS26C, 34V36C only).
- The plug is designed, for safety purposes, to fit in the wall outlet only one way. If you are unable to insert the plug fully into the outlet, contact your dealer (except KV-29RS26C, 29V36C, 34RS26C, 34V36C).
- If any liquid or solid object should fall inside the cabinet, unplug the TV immediately and have it checked by qualified personnel before operating it further.
- To prevent internal heat build-up, do not block the ventilation openings.
- Do not install the TV in a hot or humid place, or in a place subject to excessive dust or mechanical vibration.

For details concerning safety precautions, see the supplied leaflet, "IMPORTANT SAFEGUARDS".

Installing

- To prevent internal heat build-up, do not block the ventilation openings.
- Do not install the TV in a hot or humid place, or in a place subject to excessive dust or mechanical vibration.

Using This Manual

This manual is divided into four major sections. We recommend that you carefully review the contents of each section in the order provided to ensure that you fully understand the operation of your new TV.

- 1 Connecting and Installing the TV.** This section will guide you through your initial set up. It will show you how to connect your new components, connect to your antenna or cable, and connect any accessories.
- 2 Basic Set Up.** This section will teach you the basic skills needed to operate your new TV. It will show you how to operate special functions of the remote control.
- 3 Using your New TV.** This section will show you how to begin using your new TV. It will show you how to use the AUTO SET UP feature, and how to use your remote control's features.
- 4 Adjusting your Set Up (menus).** This section will teach you how to access on-screen menus and adjust your TV's settings.

Instructions in this manual are written for the remote control. Similar controls may be found on the TV console.

Connecting and Installing the TV

Making Connections

For best picture quality, a cable TV system or outdoor antenna is recommended.

Connecting directly to cable or an antenna

The connection you choose will depend on the cable found in your home. Newer homes will be equipped with standard coaxial cable (see A), older homes will probably have 300-ohm twin lead cable (see B), still other homes may contain both (see C).

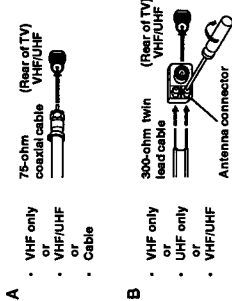

Connector Types

You may find it necessary to use some of the following connector types during set up.

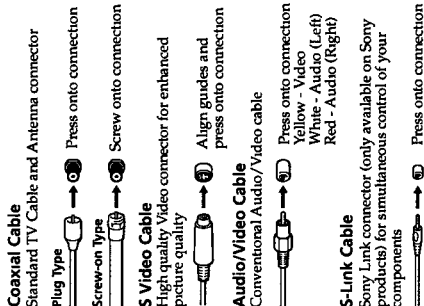

Connecting a cable box

Some pay cable TV systems use scrambled or encoded signals that require a cable box* to view all channels.

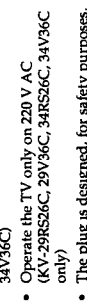

Note: If you will be controlling all channel selection through your cable box you should consider using the CHANNEL FIX feature discussed on page 22.

Cable box and cable

- KV-27526, 27V36, 29V36C, 29V76M, 32S36, 32V36, 34V36C, 35S36, 35V36, 35V76, 37V36M only

Some pay cable TV systems use scrambled or encoded signals requiring a cable box* only for certain channels (e.g. HBO, SHOWTIME, etc.)

Cable or antenna

Most simple connection. Connection is made directly from the cable or antenna to the TV.

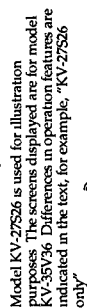

Cable and antenna

- KV-27526, 27V36, 29V36C, 29V76M, 32S36, 32V36, 34V36C, 35S36, 35V36, 35V76, 37V36M only

You may find it convenient to use the following set up if your cable provider does not feature local channels that you are able to receive using an antenna.



Select Cable or ANT mode by pressing ANT on the remote control.

Connecting and Installing the TV (continued)

Disconnect all power sources before making any connections.

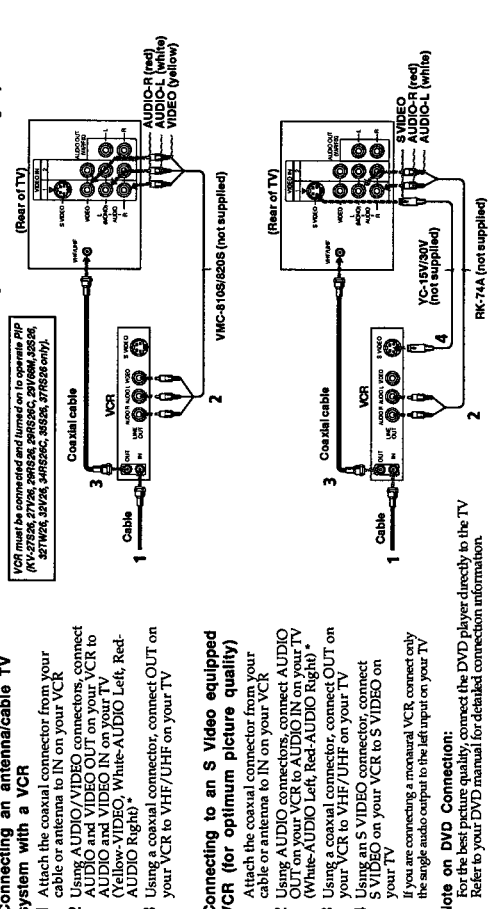

Connecting and Installing the TV (continued)

Connecting a DBS (Direct Broadcast Satellite) receiver
 Disconnect all power sources before making any connections. For the highest picture quality, use S VIDEO instead of the yellow AUDIO/VIDEO cable. See your DBS manual for more information.

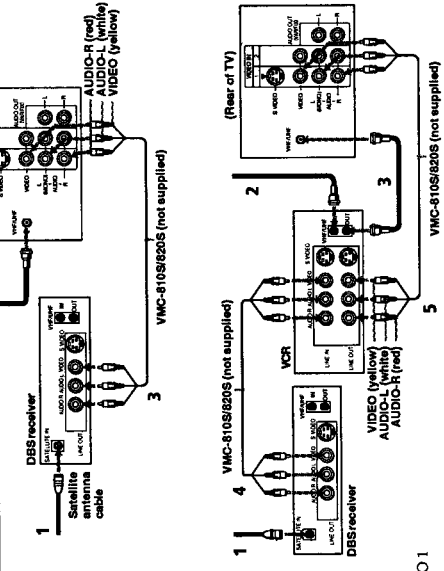

- 1 Connect the cable from your satellite antenna to your DBS receiver.
 - 2 Attach the coaxial connector from your cable or antenna to VHF/UHF-IN on your TV.
 - 3 Using AUDIO/VIDEO connectors, connect AUDIO and VIDEO OUT on your DBS receiver to AUDIO and VIDEO IN on your TV.
- Connecting a DBS (Direct Broadcast Satellite) receiver and a VCR**
- 1 Connect the cable from your satellite antenna to your DBS receiver.
 - 2 Attach the coaxial connector from your cable or antenna to VHF/UHF-IN on your VCR.
 - 3 Using a coaxial connector, connect VHF/UHF-OUT on your VCR to VHF/UHF on your TV.
 - 4 Using AUDIO/VIDEO connectors, connect AUDIO and VIDEO OUT on your DBS receiver to AUDIO and VIDEO IN on your VCR.
 - 5 Using AUDIO/VIDEO connectors, connect AUDIO and VIDEO OUT on your VCR to AUDIO and VIDEO IN on your TV.

Note:
 • To view input from the DBS or VCR, select VIDEO 1 by pressing TV/VIDEO on the remote control.

Connecting two VCRs for tape editing using MONITOR OUT

Disconnect all power sources before making any connections.

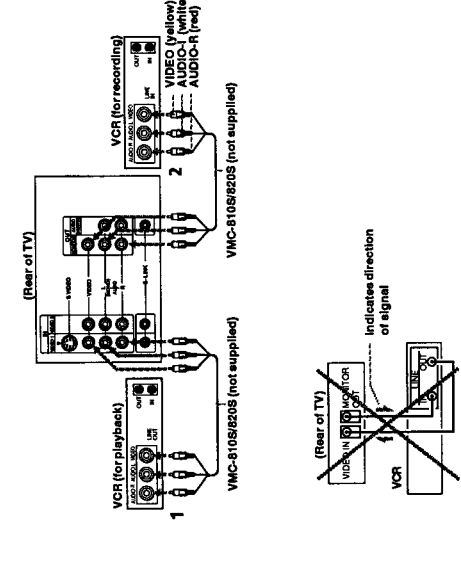

- KV-27V26, 27V28, 29V26C, 29V26M, 29V76M, 32V26, 32V28, 34V36C, 35V36, 35V76, 37V36M only
- MONITOR OUT gives you the ability to use a second VCR to record a program being played by the primary VCR or to perform tape editing and dubbing.
- 1 Connect the VCR intended for playback using the setup instructions on page 4 of this manual.
 - 2 Using AUDIO/VIDEO connectors, connect AUDIO and VIDEO IN on your VCR intended for recording to MONITOR AUDIO and VIDEO OUT on your TV.

Notes
 • Do not change the input signal while editing through MONITOR OUT.
 • When connecting a single VCR to the TV, if VCR LINE OUT is connected to TV VIDEO IN, do not connect the TV MONITOR OUT, or the TV LINE INPUT (see right). Doing so will cause program interference and other viewing problems.

Connecting a VCR and TV with a cable box

Disconnect all power sources before making any connections. VCR must be connected and turned on to operate properly. (KV-27V26, 27V28, 29V26C, 29V26M, 29V76M, 32V26, 32V28, 34V36C, 35V36, 35V76, 37V36M only.)

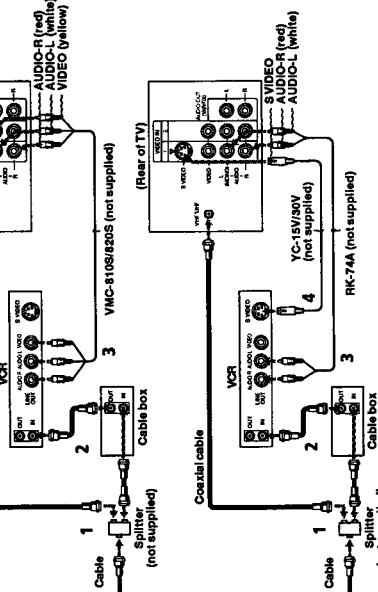

- 1 Connect the single (input) jack of the Splitter to your incoming cable connection, and connect the other two (output) jacks (using coaxial cable) to IN on your cable box and VHF/UHF on your TV.
 - 2 Using a coaxial connector, connect OUT on your cable box to IN on your VCR.
 - 3 Using AUDIO/VIDEO connectors, connect AUDIO and VIDEO OUT on your VCR to AUDIO and VIDEO IN on your TV (Yellow-VIDEO, White-AUDIO Left, Red-AUDIO Right).
- Connecting to an S Video equipped VCR (for optimum picture quality)**
- 1-2 Perform as described above.
 - 3 Using AUDIO connectors, connect AUDIO OUT on your VCR to AUDIO IN on your TV (White-AUDIO Left, Red-AUDIO Right).
 - 4 Using an S VIDEO connector, connect S VIDEO OUT on your VCR to S VIDEO on your TV.

Note:
 • To view scrambled channels through your cable box, select VIDEO 1 by pressing TV/VIDEO on the remote control.

Connecting an audio system

For greater viewing pleasure, integrate your home stereo into the system.

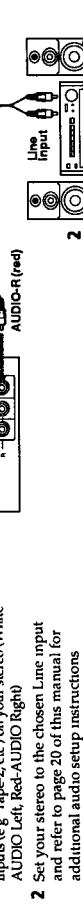

- 1 Using AUDIO connectors, connect AUDIO OUT on your TV to one of the unused Line inputs (e.g. Tape-2, etc.) on your stereo (White-AUDIO Left, Red-AUDIO Right).
- 2 Set your stereo to the chosen Line input and refer to page 20 of this manual for additional audio setup instructions.

Connecting an AV receiver

For greater viewing pleasure, connect your AV receiver.

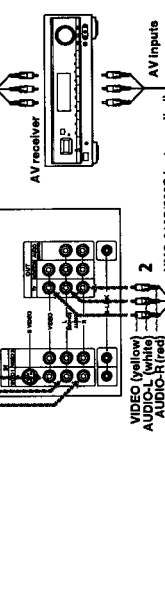

- 1 Using AUDIO/VIDEO connectors, connect VIDEO IN on your TV to Monitor AUDIO and VIDEO OUT on your AV receiver.
- 2 Using AUDIO/VIDEO connectors, connect TV OUT on your TV to TV AUDIO and VIDEO IN on your AV receiver.

You may want to use CHANNEL FIX to fix your TV's input to the AV receiver (VIDEO 1). See CHANNEL FIX, page 22.

Connecting and Installing the TV (continued)

Using the S-Link function

- KV-27V26, 27V36, 28V36C, 29V66M, 29V76M, 32V26, 32V36, 34V36C, 35V36, 35V76, 37V36M only
- S-Link is a Sony innovation designed to make your Sony components work together. It allows you to automatically switch the TV input mode to video when you press PLAY on your Sony S-Link remote control. It also allows you to turn the TV and TV off at the same time with the SYSTEM OFF button.

- Connect your VCR using the setup instructions on page 4 of this manual.
- Using an S-Link connector, connect the S-LINK jacks on your VCR and TV. Ensure the S-LINK connectors are seated firmly and that the TV S-LINK connector is in the same row as the AUDIO/VIDEO connectors.

Connecting a camcorder

- KV-27V26, 27V36, 28V36C, 29V66M, 29V76M, 32V26, 32V36, 34V36C, 35V36, 35V76, 37V36M only
- This connection is convenient for viewing a picture directly from your camcorder.

Using AUDIO/VIDEO connectors, connect AUDIO and VIDEO OUT on your camcorder to TV (VIDEO-VIDEO, White-AUDIO Left, Red-AUDIO Right).

- Note:** If you are connecting a monoaural camcorder, connect only the single audio output to the left input on your TV.

Disconnect all power sources before making any connections.

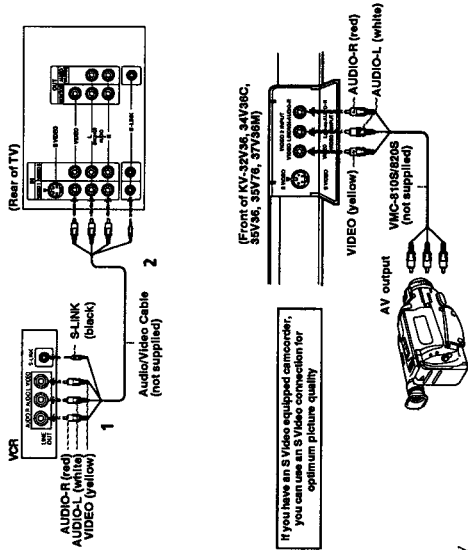

9

KV-32TW26 and KV-35V76 only

Follow these instructions to install the glass door and adjust the shelf.

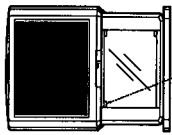

Push here to close
To open, push again

Parts List	Quantity
A Bottom hinge	1
B Top hinge	1
C Screw 6x4	4
D Plate pad	1
E Plate	1
F Metal pin	4

Note

- Confirm that all parts are included before beginning assembly. If any parts are missing, contact your dealer.

Installing the glass door

- Check that the projection of the screw through the bottom hinge A does not interfere with the proper installation of the hinge to the glass door, and then insert the hinge into the hole located at the bottom right side of cabinet.

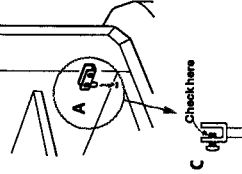

- Attach the top hinge B to the right side of the glass door, tighten the screws snugly, but do not overtighten. Attach the plate pad D to the left side and push the plate E over the plate pad.

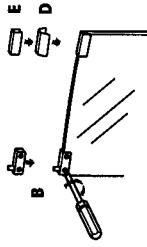

10

Basic Set up

Inserting batteries

Insert two size AA (R6) batteries (supplied) by matching the + and - on the batteries to the diagram inside the battery compartment.



Notes:

- Remove the batteries to avoid damage from possible battery leakage whenever you anticipate that the remote control will not be used for an extended period.
- Handle the remote control with care. Avoid dropping it, getting it wet, or placing it in direct sunlight, near a heater, or where the humidity is high.
- Your remote control can be programmed to operate most video equipment. See page 24.

12

Adjusting the shelf

- Press the upper part of the temporary shelf supports and remove the shelf.

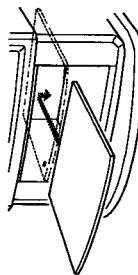

- Insert the metal pin shelf supports (2 each side).

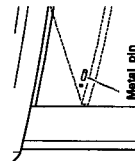

11

- Push the top glass door hinge into the top right bushing and gently slide the glass door into the bottom hinge. Adjust the glass door until level, and tighten the hinge screws.

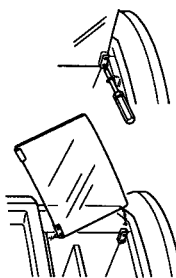

Using the remote control Select buttons

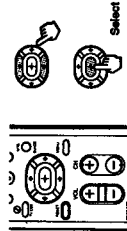

The supplied remote control has select buttons which allow for movement of the on-screen selector in four directions. Pressing on the edge of the select buttons will cause the selector to move in the selected direction. Pressing the center of the select buttons "Select" will activate the selected item.

Adjusting sliders

When menu items present a slider (← or →), use the select buttons (← or →) to adjust the setting.

On Line Help/Instructions

Several menu windows will provide prompts and instructions to assist you in navigating through the different functions. When presented, use these to supplement the instructions in this manual.

Using your New TV

Setting up the TV automatically

The EASY SETUP GUIDE feature will allow you to set the on-screen language and set all receivable channels. The EASY SETUP GUIDE screen will appear every time you turn on the TV until you perform AUTO PROGRAM.

The EASY SETUP GUIDE feature does not apply for installations that use a cable box for all channel selection.

To set up the TV manually, refer to "Using the SET UP menu" on page 22.

Tips

- Perform the function during the day, with the antenna and/or cable properly connected, to ensure that all available channels will be tracked and receivable.
- After using EASY SETUP GUIDE, you will still have the option of changing any of the system settings, like receiving channels, through the SET UP menu (page 22).
- The TV must be set to TV format to use the AUTO PROGRAM Press ANT until the channel number appears.
- If you cable or antenna is connected to AUX, then press TV, VOL +, or CHANNEL + to select the channel number (KV-27V36, 29V76M, 29V66M, 32V36, 32V36C, 34V36C, 35S26, 35V76, 37V36M only).

Using the buttons on the front of the TV

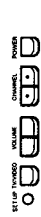

For KV-27V36, 29V36C, 29V76M, 32V36, 34V36C, 35V36, 35V76 and 37V36M, the control buttons are located on the top of the TV.

- Press POWER to turn on the TV. The EASY SETUP GUIDE screen appears.

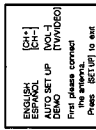

- (Except Canadian models) Press CHANNEL + to select English screens or CHANNEL - to select Spanish screens.



- Press VOLUME - to continue or TV / VIDEO for a DEMO of functions and menus.



"AUTO PROGRAM" appears and the TV starts scanning and presetting channels automatically. When all the receivable channels are stored, the lowest numbered channel is displayed. If the TV receives cable TV channels, CABLE is set ON automatically.

To perform AUTO SET UP again

- Press SET UP.
- Press CHANNEL + or CHANNEL - to select a language.
- Press VOLUME - to restore factory settings ("CONTINUE TO AUTO PROGRAM?") will appear on the screen. Press CH+ to execute or CH- to exit.
- Press SET UP to exit.

Note

- When you perform AUTO PROGRAM, your CHANNEL FIX, TIMER, and CHANNEL BLOCK settings will be erased.

Using your New TV (continued)

Watching the TV

All of the TV features can be accessed via the remote control. The following chart will explain the function of the buttons found on your remote control.

REFER TO THE ILLUSTRATION OF THE REMOTE CONTROL ON THE INSIDE FRONT COVER OF THIS MANUAL AS YOU REVIEW THIS CHART.

TV (FUNCTION)	Activates the remote control for use with the TV
TV POWER	Turns the TV on and off. If "VIDEO" appears on the screen, press TV/VIDEO or ANT so that a channel number appears.
CH +/-	Use for direct channel selection. Press 0-9 to select a channel (for example, to select channel 10, press 1 and 0), the channel will change after 2 seconds, or you can press ENTER for immediate selection.
VOL +/-	Press to scan through the channels (+ up or - down).
JUMP	Press to alternate or jump back and forth between two channels. You can only jump between the last two channels that have been selected with the 0-9 keys.
MUTING	Press to mute the sound ("MUTING" will appear on the screen). Press again or press VOL + to restore sound.
FREEZE	Press to freeze the window picture while in PIP mode. If you are not in PIP mode, pressing FREEZE will cause the main picture to freeze into a window picture. Great for copying down phone numbers, addresses, recipes, etc.

14

Using your New TV (continued)

Watching two programs at one time — PIP

The Picture-in-Picture (PIP) feature allows you to view two channels simultaneously, one in the full size "main" picture and one in a smaller "window" picture. This means that two separate tuners must be available to provide the two signals.

Certain models (KV-27V36, 27V26, 29V36C, 29V66M, 32V36, 34V36C, 35S26, 37V36M only) are equipped with a single tuner. This simply means that a VCR must be connected and turned on for PIP to operate using PIP.

Tip

To ensure correct single tuner PIP connection (KV-27V36, 27V26, 29V36C, 29V66M, 32V36, 32V36C, 34V36C, 35S26, 37V36M only), make sure the following list of simple connections is complete before using PIP:

- A cable or antenna is connected to the VCR.
- The VCR is connected to your TV.
- The VCR is turned on.

(For detailed connection information, see page 3-5.)

Note:

- You must press TV (FUNCTION) before you can control PIP with the yellow labeled buttons.

15

SLEEP	Press repeatedly until the TV displays the approximate time in minutes (60, 80, or 90) that you want the TV to remain on before shutting off automatically. Cancel by pressing until "SLEEP OFF" appears.
DISPLAY	Press repeatedly to step through available displays: Status Channel number, current time, channel caption (if set), and MTS mode (if SAP is selected) are displayed. SAP indication disappears after three seconds. XDS (Extended Data Service) shows a network name, program name, program type, program length, call letters, and time of the show if the broadcaster offers this service. Caption Vision. Caption Vision will be displayed on the screen if the broadcaster offers this service (see right). To cancel the display, press DISPLAY repeatedly until "DISPLAY OFF" appears. "DISPLAY OFF" disappears after three seconds.
TV/VIDEO	Press repeatedly to step through available video inputs: TV, Video 1 and Video 2 (KV-27V36, 27V26, 29V36C, 29V66M, 32V36, 32V36C, 34V36C, 35S26, 35V76, 37V36M only). TV, Video 1, Video 2 and Video 3 (KV-27V26, 27V36, 29V36C, 29V66M, 29V76M, 32V26, 32V36, 34V36C, 35V36, 35V76, 37V36M only). Press to change the VHF/UHF input to the AUX input (KV-27V36, 27V36, 29V36C, 29V76M, 32V36, 32V36C, 34V36C, 35S26, 35V76, 37V36M only). For detailed connection information, see "Cable box and cable" or "Cable and antenna" on page 3.
ANT	Press to turn off the TV and all other equipment connected with S-Link and return the TV input to either antenna or AUX, whichever was last used.
SYSTEM OFF	Press this button to cycle through the Multi-channel TV Sound (MTS) options. (page 20)
MTS/GUIDE	

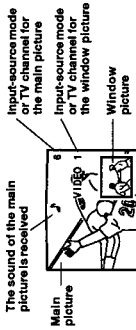

REFER TO THE ILLUSTRATION OF THE REMOTE CONTROL ON THE INSIDE FRONT COVER OF THIS CHART.

Use the Yellow Labeled Buttons for PIP Operations	
PIP	Press once to display the window picture (1/3 size). Press again to reduce the size of the window picture (1/16 size). Press a third time to remove the window picture.
TV/VIDEO	Press repeatedly to step through available video inputs: TV, Video 1, Video 2, and Video 3 (KV-27V26, 27V36, 29V36C, 29V66M, 29V76M, 32V26, 32V36, 34V36C, 35V36, 35V76, 37V36M only). If you use one of the connections from page 4, your PIP input source is the VCR. If you use one of the connections from page 5, your PIP input source is a VCR or cable box.
AUDIO	Press to alternate sound between the main picture and the window picture. A 2 will appear for a few seconds to indicate which picture is receiving sound.

Use the Yellow Labeled Buttons for PIP Operations

TV/VTR + CH - CH	Press to change the TV channel in the window picture (+ to increase the channel number and - to decrease). For models KV-27S26, 27V26, 29RS26C, 29V66M, 32S26, 32TW26, 34RS26C, 35S26, and 37RS26, if you are watching the video input in the window picture, you must press VTR (FUNCTION), then use the main CH +/- buttons to change channels.
POSITION	Press to move the location of the window picture (counterclockwise) around the main picture.
FREEZE	Press to freeze the window picture. Great for copying down phone numbers, addresses, recipes, etc. If a window picture is displayed, then it will be frozen. If only the main picture is displayed, then it will be frozen and displayed as a window picture. Press FREEZE again to restore the previous screen(s).
SWAP	Press to switch the audio and video of the main picture and the window picture. Each time you press SWAP, the picture and sound of the two will be SWAPPED. The channels being received through the AUX jack cannot be displayed as a window picture (KV-27S36, 27V36, 29V36C, 29V76M, 32S36, 32V36, 34V36C, 35S36, 35V76, 37RS36, 37V36M only).

Adjusting your SET UP (menus)

Learning menu selection

Use the MENU button to access a menu and use the Select buttons to alter settings. Use the following example to learn how to modify settings.

- 1 Press the MENU button. The main menu appears.



- 2 Press the select buttons (left or right) to highlight the desired menu and press (Enter) to activate it.



- 3 Press the select buttons (left or right) to select the desired option.

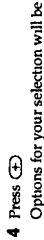

- 4 Press (Enter). Options for your selection will be displayed.

When you are done with changes to the selected menu, choose MENU to return to the main menu. Once you have completed all menu connections, press MENU on the remote control to exit the menu screens.

Note

- Pressing MENU on the remote control will allow you to exit from the menus.

- 5 Make your selection and press (Enter) to activate it. The previous screen will reappear.



Adjusting your SET UP (menus) (continued)

Using the AUDIO menu



For detailed information on using the remote to modify menu settings, refer to "Learning menu selection" on page 18.

To select the AUDIO menu:

- Display (MENU) → Highlight (BASS) → Select (Enter)

To restore the factory settings

Press RESET on the remote control while the AUDIO menu is displayed.

- Tip
- Press (Enter) for direct selection of an EFFECT setting.

Using the VIDEO menu



For detailed information on using the remote to modify menu settings, refer to "Learning menu selection" on page 18.

To select the VIDEO menu:

- Display (MENU) → Highlight (MODE) → Select (Enter)

To restore the factory settings

Press RESET on the remote control while the VIDEO menu is displayed.

TREBLE Sound Adjustment	Adjust slider left (cursor down) to decrease higher pitched sounds Adjust slider right (cursor up) to increase higher pitched sounds
BASS Sound Adjustment	Adjust slider left (cursor down) to decrease low pitched sounds Adjust slider right (cursor up) to increase low pitched sounds
BALANCE Sound Adjustment	Adjust slider left (cursor down) to emphasize left speaker volume Adjust slider right (cursor up) to emphasize right speaker volume
EFFECT Customize sound effect based on the program's audio type	SURROUND: Simulates theater quality sound (only for stereo programs). (KV-27S36, 27V36, 29RS26, 29S26C, 32S26, 32TW26, 34RS26C, 35S26, 35V76, 37RS26, 37V36M only) SFS: Produces a dynamic three dimensional sound for stereo or encoded audio signals (KV-27V26, 27V36, 29V36C, 29V66M, 29V76M, 32V26, 32V36, 34V36C, 35V36, 35V76, 37V36M only) SIMULATED: Adds a surround-like effect to mono programs. (KV-27V26, 27V36, 29V36C, 29V66M, 29V76M, 32V26, 32V36, 34V36C, 35V36, 35V76, 37V36M only)
MTS Enjoy stereo, bilingual and mono programs.	STEREO: Select for stereo reception when viewing a program broadcast in stereo. SAP: Select to listen to bilingual broadcast (non-SAP programs will be muted when this feature is selected) MONO: Select for mono reception (use to reduce noise during stereo broadcasts) Quick MTS access: Press MTS on your remote to cycle through the MTS options as follows (STEREO → SAP → MONO → STEREO)
SPEAKER Custom selection of audio output source	ON: Select to listen to the sound from the TV speakers and a separate stereo system. OFF: Select to turn off the TV speakers and listen to the TV's sound only through external audio system speakers.
AUDIO OUT Easy control of volume adjustments.	AUDIO OUT can only be set when speakers are set to OFF. VARIABLE: Sound output varies according to the TV settings. Volume, Bass, Treble, and Balance are adjusted through the TV. Useful when you want to use external speakers. FIXED: Sound output is held as a fixed level. Volume, Bass, Treble, and Balance are fixed to the factory settings. Volume adjustments are made through your stereo.

Adjusting your SET UP (menus) (continued)

Using the SET UP menu



CHANNEL SET UP
Basic set up options for viewing

With the CHANNEL SET UP window open
1 Use \leftarrow or \rightarrow to select the feature you want to change
2 Press \rightarrow to access the feature
3 Press \rightarrow to access the feature
4 Press \rightarrow to access the feature
5 Press \rightarrow to access the feature
6 Press \rightarrow to access the feature
7 Press \rightarrow to access the feature
8 Press \rightarrow to access the feature
9 Press \rightarrow to access the feature
10 Press \rightarrow to access the feature
11 Press \rightarrow to access the feature
12 Press \rightarrow to access the feature
13 Press \rightarrow to access the feature
14 Press \rightarrow to access the feature
15 Press \rightarrow to access the feature
16 Press \rightarrow to access the feature
17 Press \rightarrow to access the feature
18 Press \rightarrow to access the feature

CHANNEL SET UP
1 CHANNEL FIX OFF
2 CHANNEL BLOCK
3 VIDEO LABEL
4 VIDEO CORRECTION
5 SLEEP
6 SLEEP
7 SLEEP
8 SLEEP
9 SLEEP
10 SLEEP
11 SLEEP
12 SLEEP
13 SLEEP
14 SLEEP
15 SLEEP
16 SLEEP
17 SLEEP
18 SLEEP

CHANNEL FIX Use this feature to set the TV's input to one of the following options.
2-6 Choose when the cable box is connected to the VHF/UHF input and you do not want to switch to AUX mode. Once the setting is made you will not be able to use the "TV function" CH+/- to change channels, instead, use the "Cable function" CH+/-.
AUX 2-6 Choose when a cable box is connected to AUX and a cable or antenna is connected to ANT. You can alternate between the two inputs by pressing ANT on the remote control (KV-27536, 27V36, 29V36C, 29V76M, 32S36, 32V36, 34V36C, 35S36, 35V36, 35V76, 37V36M only).
VIDEO 1 Input that you only have connected video equipment (e.g. AV receiver) and you want TV input forced to it. You will only be able to switch between video sources **TIMER and CHANNEL BLOCK** settings are erased when **CHANNEL FIX** is set **AUTO PROGRAM**. Instructs the TV to automatically program all receivable channels **CHANNEL ERASE/ADD**. With the CHANNEL ERASE/ADD window open
1 Place the cursor next to ERASE or ADD
2 Select the cleared channel using CH+/-, or by selecting with the 0-9 buttons and pressing ENTER
3 Press \rightarrow to activate
CHANNEL CAPTION With the CHANNEL CAPTION window open
1 Press \rightarrow and then \rightarrow or \rightarrow on the select buttons to select the desired channel, and press \rightarrow again
2 Press \rightarrow or \rightarrow on the select buttons to display the first letter or number of the caption and press \rightarrow to select it (Repeat until all four digits are selected)
3 Press \rightarrow to activate To erase a Caption, press RESET

For detailed information on using the remote to modify menu settings, refer to "Learning menu selection" on page 18

To select the SET UP menu:



If any menu items are "grayed out", press the ANT button on your remote so that a channel number appears

Favorite channel feature is not available for the AUX input

22

Using the TIMER menu



DAYLIGHT SAVING
Automatically adjusts the time.

Spring Select YES to compensate for Daylight Saving Time
The current time automatically moves one hour ahead
Fall Select NO at the end of Daylight Saving Time
The current time moves back one hour

CURRENT TIME SET
Necessary for the TIMER

CURRENT TIME SET window will appear
1 Press \rightarrow or \rightarrow on the select buttons until the current day (MON-SUN) is displayed. Press \rightarrow to select
2 Press \rightarrow or \rightarrow on the select buttons until the current hour (01-12) and AM/PM is displayed. Press \rightarrow to select
3 Press \rightarrow or \rightarrow on the select buttons until the current minute (00-59) is displayed
4 Press \rightarrow

After setting the clock you can use the timer to turn the TV on and off

For detailed information on using the remote to modify menu settings, refer to "Learning menu selection" on page 18

To select the TIMER menu:

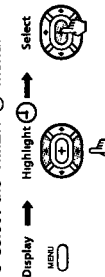

Tip
Set day/night saving time before setting the clock. Any loss of power will cause these settings to be erased

ON/OFF TIMER
Wake up or scheduled viewing
1 Press \rightarrow or \rightarrow on the select buttons until the desired day (MON-SUN) or range of days (EVERY Sun-Sat or EVERY Mon-Fri) is displayed. Press \rightarrow to select
2 Indicate the time (hours then minutes) that you want the TV to turn on by pressing \rightarrow or \rightarrow and then \rightarrow
3 Set the time duration (maximum of 6 hours) by pressing \rightarrow or \rightarrow and then \rightarrow
4 Press \rightarrow or \rightarrow on the select buttons to select the cleared channel. Press \rightarrow to select
5 Press \rightarrow or \rightarrow on the select buttons to select the cleared channel. Press \rightarrow to select
6 Press \rightarrow or \rightarrow on the select buttons to select the cleared channel. Press \rightarrow to select
7 Press \rightarrow or \rightarrow on the select buttons to select the cleared channel. Press \rightarrow to select
8 Press \rightarrow or \rightarrow on the select buttons to select the cleared channel. Press \rightarrow to select
9 Press \rightarrow or \rightarrow on the select buttons to select the cleared channel. Press \rightarrow to select
10 Press \rightarrow or \rightarrow on the select buttons to select the cleared channel. Press \rightarrow to select
11 Press \rightarrow or \rightarrow on the select buttons to select the cleared channel. Press \rightarrow to select
12 Press \rightarrow or \rightarrow on the select buttons to select the cleared channel. Press \rightarrow to select
13 Press \rightarrow or \rightarrow on the select buttons to select the cleared channel. Press \rightarrow to select
14 Press \rightarrow or \rightarrow on the select buttons to select the cleared channel. Press \rightarrow to select
15 Press \rightarrow or \rightarrow on the select buttons to select the cleared channel. Press \rightarrow to select
16 Press \rightarrow or \rightarrow on the select buttons to select the cleared channel. Press \rightarrow to select
17 Press \rightarrow or \rightarrow on the select buttons to select the cleared channel. Press \rightarrow to select
18 Press \rightarrow or \rightarrow on the select buttons to select the cleared channel. Press \rightarrow to select

The timer is now set. The TIMER indicator on your TV will lit Press MENU to exit. When you perform AUTO PROGRAM, all TIMER settings will be erased

21

Operating video equipment

Setting the manufacturer's code

You can use the supplied remote control to operate Sony or non-Sony video equipment that has an infrared sensor

- 1 Press CODE SET
- 2 Press VTR (FUNCTION)
- 3 Use the 0-9 buttons to key in the manufacturer's code number from the following chart
- 4 Press ENTER

VCR manufacturer code numbers

Manufacturer	Code
Aony	301, 302, 303
Aswa	338, 344
Admiral (M Wards)	327
Audio Dynamic	314, 337
Bell & Howell (M Wards)	330, 343
Philco	319, 317
Pioneer	309, 308
Canon	309, 306
Citizen	309, 302
Oring	315, 302, 315
Curts Mathis	304, 338, 309

24

CHANNEL BLOCK

You will be able to block two channels. With the CHANNEL BLOCK window open
1 Select 1 or 2 and press \rightarrow
2 Press \rightarrow or \rightarrow on the select buttons to display the channel you want to block
3 Press \rightarrow to select the channel you want to block
4 Press \rightarrow to select the channel you want to block
5 Press \rightarrow to select the channel you want to block
6 Press \rightarrow to select the channel you want to block
7 Press \rightarrow to select the channel you want to block
8 Press \rightarrow to select the channel you want to block
9 Press \rightarrow to select the channel you want to block
10 Press \rightarrow to select the channel you want to block
11 Press \rightarrow to select the channel you want to block
12 Press \rightarrow to select the channel you want to block
13 Press \rightarrow to select the channel you want to block
14 Press \rightarrow to select the channel you want to block
15 Press \rightarrow to select the channel you want to block
16 Press \rightarrow to select the channel you want to block
17 Press \rightarrow to select the channel you want to block
18 Press \rightarrow to select the channel you want to block

Setting FAVORITE CHANNEL
With the FAVORITE CHANNEL window open
1 Press \rightarrow and then \rightarrow or \rightarrow on the select buttons to select AUTO or MANUAL, and press \rightarrow again
2 Press \rightarrow or \rightarrow on the select buttons to select 1, 2, 3, 4, or 5 and press \rightarrow
3 Press \rightarrow or \rightarrow on the select buttons to select the channel you want to watch, and press \rightarrow
4 For KV-27536, 27V36, 29V36C, 29V76M, 32S36, 32V36, 34V36C, 35S36, 35V36, 35V76, 37V36M only, you can preview your favorite channels in the window picture, to do so, set PREVIEW DISPLAY to ON
Using FAVORITE CHANNEL
1 Press \rightarrow and your FAVORITE CHANNEL options appear
2 Press \rightarrow or \rightarrow to select the channel you want to watch, and press \rightarrow
3 For models KV-27536, 27V36, 29V36C, 29V76M, 32S36, 32V36, 34V36C, 35S36, 35V36, 35V76, 37V36M only, if PREVIEW is turned on, then a window picture will display your favorite channels as you cycle through the options

VIDEO LABEL

This feature allows you to label each input mode so that you can easily identify the connected equipment (e.g. you can label VIDEO 1 IN as VHS)
1 Press \rightarrow or \rightarrow on the select buttons to select the input mode you want to label and press \rightarrow
2 Press \rightarrow or \rightarrow on the select buttons to select the label and press \rightarrow
3 Press \rightarrow or \rightarrow on the select buttons to select the label and press \rightarrow
4 Press \rightarrow or \rightarrow on the select buttons to select the label and press \rightarrow
5 Press \rightarrow or \rightarrow on the select buttons to select the label and press \rightarrow
6 Press \rightarrow or \rightarrow on the select buttons to select the label and press \rightarrow
7 Press \rightarrow or \rightarrow on the select buttons to select the label and press \rightarrow
8 Press \rightarrow or \rightarrow on the select buttons to select the label and press \rightarrow
9 Press \rightarrow or \rightarrow on the select buttons to select the label and press \rightarrow
10 Press \rightarrow or \rightarrow on the select buttons to select the label and press \rightarrow
11 Press \rightarrow or \rightarrow on the select buttons to select the label and press \rightarrow
12 Press \rightarrow or \rightarrow on the select buttons to select the label and press \rightarrow
13 Press \rightarrow or \rightarrow on the select buttons to select the label and press \rightarrow
14 Press \rightarrow or \rightarrow on the select buttons to select the label and press \rightarrow
15 Press \rightarrow or \rightarrow on the select buttons to select the label and press \rightarrow
16 Press \rightarrow or \rightarrow on the select buttons to select the label and press \rightarrow
17 Press \rightarrow or \rightarrow on the select buttons to select the label and press \rightarrow
18 Press \rightarrow or \rightarrow on the select buttons to select the label and press \rightarrow

23

Operating a cable box or DBS receiver

Programming the remote

You can program the supplied remote control to operate a cable box or DBS receiver

- 1 Press CODE SET
- 2 Press DBS/CABLE (FUNCTION)
- 3 Use the 0-9 buttons to key in the manufacturer's code number from the following chart
- 4 Press ENTER

Manufacturer code numbers (cable box)

Manufacturer	Code number
Hamilin/Kegal	222, 223, 224, 225, 226
Jerrold/G I.	201, 202, 203, 204, 205, 206, 207, 208, 218
Panasonic	227, 228, 229
Pioneer	219, 220, 221
Scientific Atlanta	214, 215
Toocom	209, 210, 211
Zenith	216, 217
	212, 213

Manufacturer code numbers (DBS receiver)

Manufacturer	Code number
Sony	801 (preset code for remote control)
General Electric	802
RCA/PROSCAN	802

If the remote control doesn't work

First, try repeating the setup procedures using the other codes listed for your equipment

- Tips**
- If more than one code number is listed, try entering them one by one until you come to the correct code for your equipment
 - If you enter a new code number, the code number you previously entered at that setting is erased
 - In some rare cases, you may not be able to operate your equipment with the supplied remote control. In this case, use the equipment's own remote control unit
 - Whenever you remove the batteries—to replace them, for example—if too much time is taken, the code numbers may revert to the factory setting and must be reset

To operate the TV

Press TV (FUNCTION). Then use the TV control buttons to control the TV

For more details on operating the cable box or DBS receiver

Refer to the operating instructions that come with the equipment

Operating a VCR

Buttons on the remote control

- To turn on or off: Press VTR (POWER)
- To select a channel directly: Press the 0-9 buttons
- To change channels: Press CH +/-
- To record: Press \blacktriangle while pressing \bullet . First release \blacktriangle , then release \bullet
- To play: Press \blacktriangle
- To stop: Press \blacksquare
- To rewind the tape: Press \blacktriangle
- To pause: Press II
- To resume normal playback, press again: Press \blacktriangle or \blacktriangle during playback. To resume normal playback, release the button
- To change input mode: Press TV/VTR

- 702
702, 709
706
705
703, 708
- Tips**
- In some rare cases, you may not be able to operate your Sony video equipment with the supplied remote control. In this case, please use the equipment's own remote control
 - The code numbers for Sony equipment are assigned at the factory as follows

- VHS VCR 301 (preset code for the supplied remote control)
- 8 mm VCR 302
- Beta, ED Beta VCRs 303
- When you remove the batteries, the code number may revert to the factory setting

Troubleshooting

Cannot receive upper channels (UHF) when using an antenna

- Make sure CABLE is OFF in the SET UP menu (page 22)
- Use AUTO PROGRAM to add receivable channels that are not presently in TV memory (page 22)

Cannot receive any channels when using cable TV

- Make sure CABLE is ON in the SET UP menu (page 22)
- Use AUTO PROGRAM to add receivable channels that are not presently in TV memory (page 22)

Remote control does not operate

- Batteries could be weak. Replace the batteries
- Press TV (FUNCTION) when operating your TV
- Make sure the TV's power cord is connected securely to the wall outlet
- Locate the TV at least 3-4 feet away from fluorescent lights
- Check the S-Link connection (page 4, 5)

Black and white programs cannot be seen in color

- Perform AUTO SET UP again using the SET UP button to return to the factory preset condition (page 13)

Troubleshooting

Cannot Operate Single-Tuner PIP (KV-27S26, 27V26, 28FS26, 28FS26C, 28V68M, 28S26, 32T1W26, 34FS26C, 34S26, 37FS26 only)

- Check that cable is connected to the VCR, and the VCR is turned on
- Check that the VCR is connected to the TV

No picture (screen not lit), no sound

- Make sure the power cord is plugged in
- Operate with the buttons on the TV and the remote control
- Insert the batteries in the remote control with the correct polarity
- Replace the batteries with new ones if they are weak
- Check to see if the TV/VIDEO setting is correct. When watching TV, set to TV, and when watching video tapes, set to VIDEO1, 2, or 3
- Try another channel. It could be station trouble
- Perform AUTO SET UP again using the SET UP button to return to the factory preset condition (page 13)

Troubleshooting (continued)

Cannot gain enough volume when using a cable box

- Increase the volume at the cable box. Then press TV (FUNCTION) and adjust the TV's volume
- Try turning CHANNEL FIX off (see page 22)

Use AUTO PROGRAM to add receivable channels that are not presently in TV memory (page 22)

- Use AUTO PROGRAM to add receivable channels that are not presently in the TV memory (page 22)
- To reset the TV. First, turn the TV on. Then, while pressing the RESET key on the TV, the TV will turn itself off, then back on. When the TV turns on again, all settings will be reset, and the EASY SETUP GUIDE will appear

TV malfunctions when using the S-Link function (KV-27V26, 27V26, 28V36C, 28V68M, 28V76M, 32V26, 32V36, 34V36C, 35V36, 36V76, 37V36M only)

- Make sure the TV's power cord is connected securely to the wall outlet
- Make sure the TV's power cord is connected securely to the wall outlet
- Check the S-Link connection (page 4, 5)

Poor or no picture (screen lit), good sound

- Adjust PICTURE in the VIDEO menu (page 19)
- Adjust BRIGHTNESS in the VIDEO menu (page 19)
- Check antenna/cable connections
- Perform AUTO SET UP again using the SET UP button to return to the factory preset condition (page 13)
- Remove objects from the front of TV
- Check the LIGHTSENSOR setting in the VIDEO menu (page 19)

Good picture, no sound

- Press MUTING so that "MUTING" disappears from the screen (page 14)
- Check the MTS setting in the AUDIO menu (page 20)
- Make sure SPEAKER is set to ON in the AUDIO menu (page 20)
- Perform AUTO SET UP again using the SET UP button to return to the factory preset condition (page 13)

No color

- Adjust the COLOR in the VIDEO menu (page 19)
- If the item you want to choose appears in gray, you cannot select it. Press TV/VIDEO correctly

SECTION 2 DISASSEMBLY

2-1-1. REAR COVER REMOVAL (32V26/32V36/34V36C)

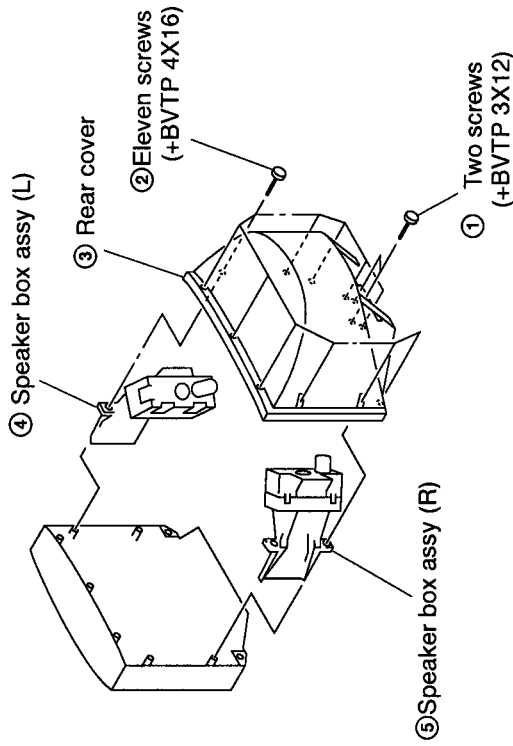

2-1-2. REAR COVER AND SPEAKER REMOVAL (35V36/35V76/37V36M)

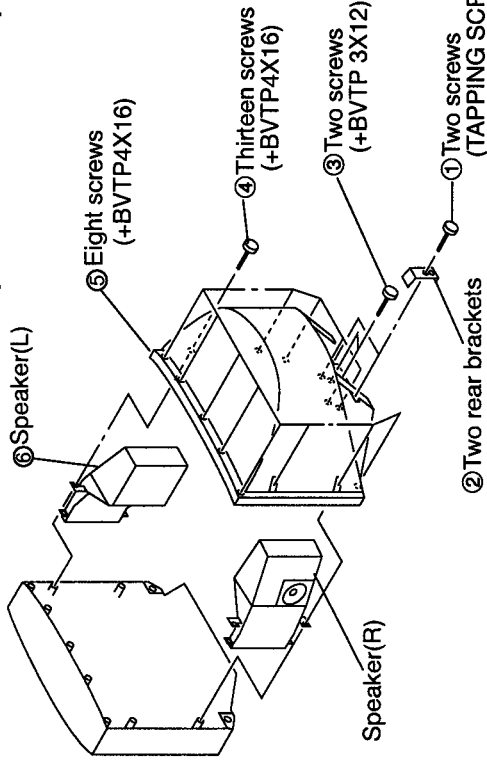

2-2. CHASSIS ASSY REMOVAL

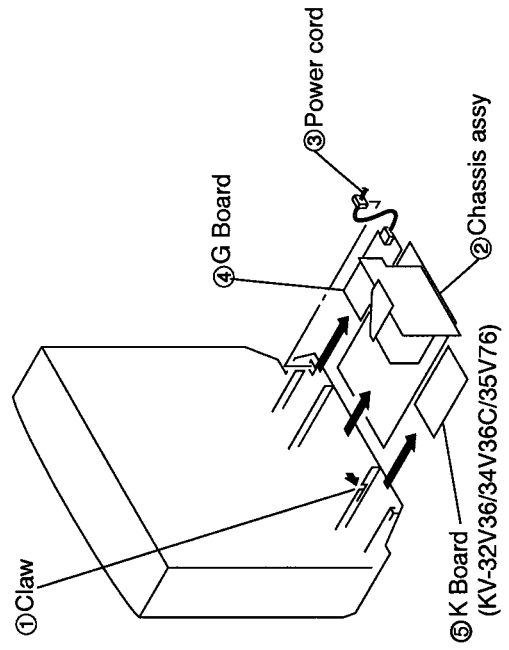

2-3. CABINET BASE REMOVAL (KV-35V76)

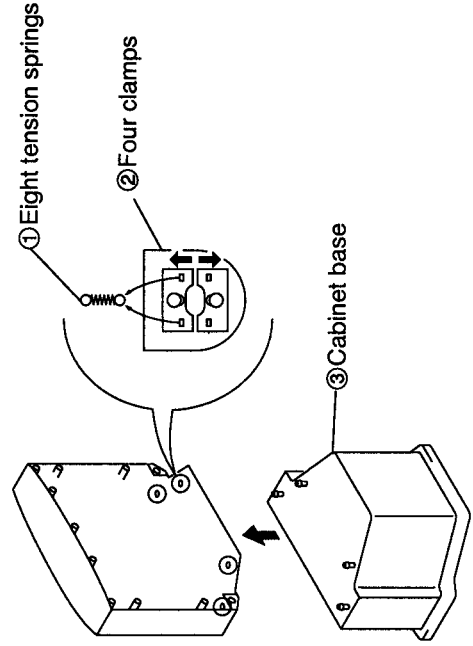

2-4. SERVICE POSITION

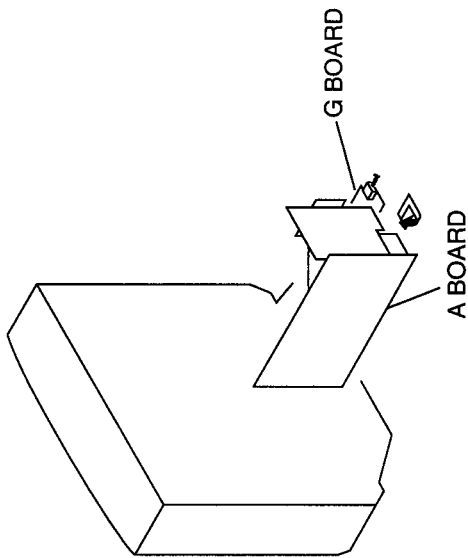

2-5. CONTROL SWITCH REMOVAL

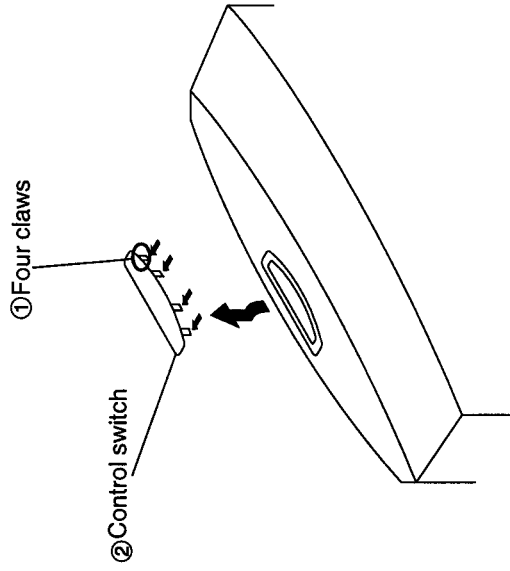

• REMOVAL OF THE ANODE-CAP

NOTE: Short circuit the anode of the picture tube and the anode cap to the metal chassis, CRT shield or carbon painted on the CRT, after removing the anode.

• REMOVAL PROCEDURES

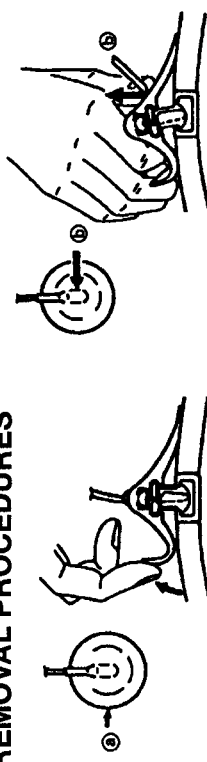

- ① Turn up one side of the rubber cap in the direction indicated by arrow ①.
- ② Use your thumb to pull the rubber cap firmly in the direction indicated by arrow ②.
- ③ When one side of the rubber cap separates from the anode button, the anode-cap can be removed by turning the rubber cap and pulling it in the direction of arrow ③.

• HOW TO HANDLE AN ANODE-CAP

- ① Do not use sharp objects which may cause damage to the surface of the anode-cap.
- ② Do not squeeze the rubber covering too hard to avoid damaging the anode-cap. A material fitting called a shatter-hook terminal is built into the rubber.
- ③ Do not force turn the foot of the rubber cover. This may cause the shatter-hook terminal to protrude and damage the rubber.

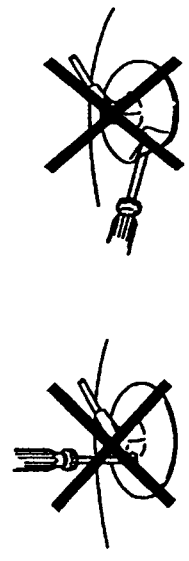

2-6-1. PICTURE TUBE REMOVAL (KV-32V26/32V36/34V36C)

WARNING : Before removing anode cap, make certain the H.V. remains in the CRT even after the power is disconnected.

To avoid electrical shock, remove the anode cap before attempting to discharge CRT: Short between anode and CRT coated earth ground strap.

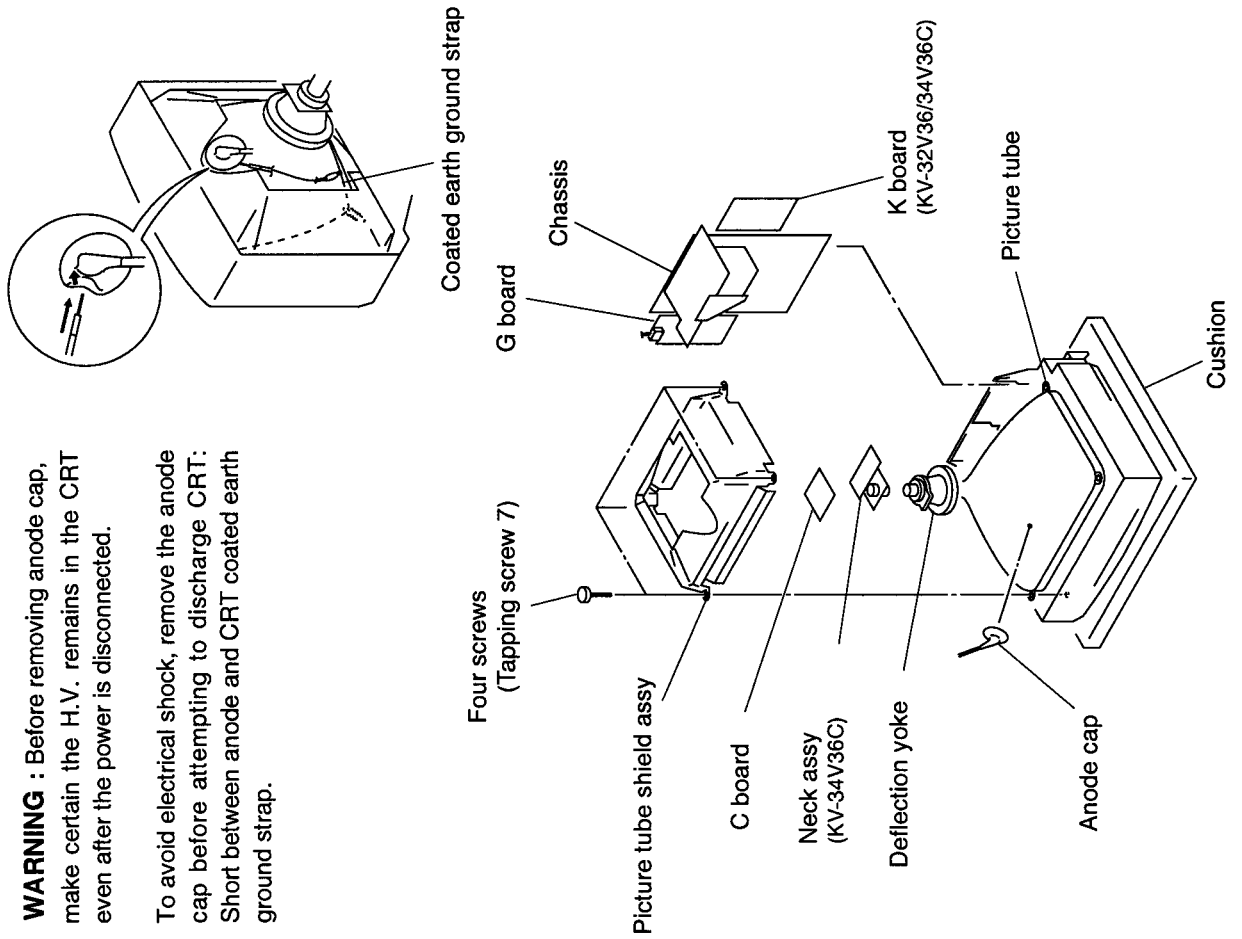



2-6-2. PICTURE TUBE REMOVAL (KV-35V36/35V76/37V36M)

WARNING : Before removing anode cap, make certain the H.V. remains in the CRT even after the power is disconnected.

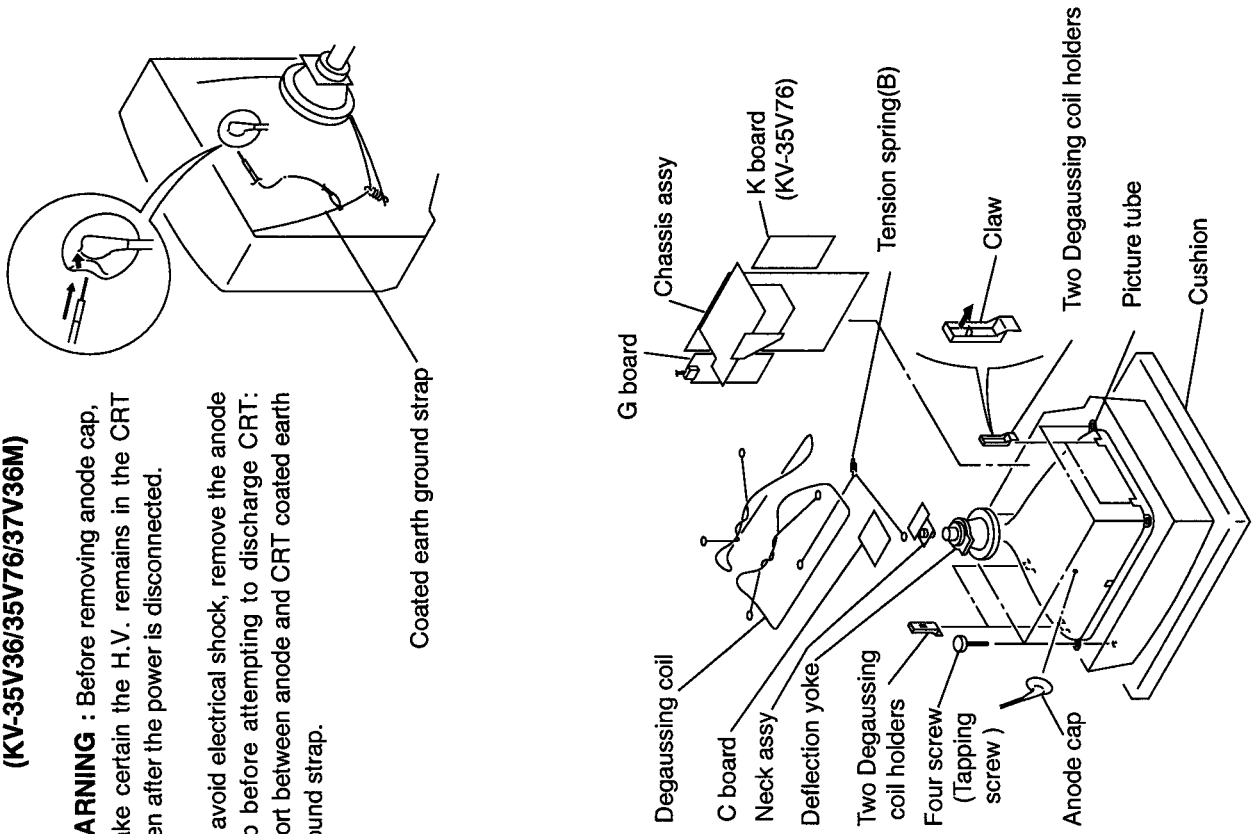
To avoid electrical shock, remove the anode cap before attempting to discharge CRT: Short between anode and CRT coated earth ground strap.

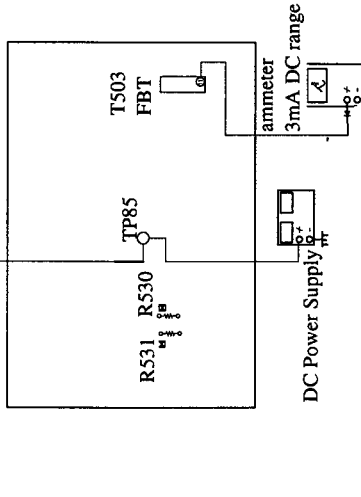
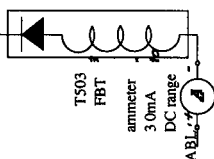

SECTION 3 SAFETY RELATED ADJUSTMENTS

ADJUSTMENT ITEM AND PROCEDURE	EQUIPMENT AND SIGNAL	MEASUREMENT POSITION	ADJUSTMENT LOCATION	ILLUSTRATION AND SHAPE AND NUMBER
<p>RESISTOR CONFIRMATION METHOD (HOLD-DOWN CONFIRMATION) AND READJUSTMENTS</p> <p>The following adjustments should always be performed when replacing the components marked with  on the A and G Board schematic diagrams. (Hold-down operation confirmation)</p> <p>Step 1 Preparation before confirmation: a) Turn the POWER switch ON, input a white signal and set the PICTURE and BRIGHTNESS controls to maximum.</p> <p>b) Confirm that the voltage at the check terminal of TP85 is more than 18.0 VDC when the set is operating normally. (120 ± 2.0 VAC) or (220 ± 2.0 VAC for KV-34V36C)</p> <p>Step 2 Input a white signal and verify that I ABL is within the specified range.</p> <p>Step 3 Record the voltage between TP85 and ground.</p> <p>Step 4 Using an external DC power supply, apply voltage between TP 85 and ground. Increase the voltage gradually and confirm that the hold-down works (raster disappears) at lower than the voltage recorded in Step 3.</p> <p>Step 5 Confirm that a voltage of more than 18.0 VDC appears between TP85 and ground.</p>	<p> marked parts A Board IC351, IC501 D519, D520, D521, C531, C532, R387, R529, R530, R531 R532, R533, R550, T503 G Board IC643, R661</p> <p>TP85 (H. PROT)</p> <p>White Picture</p> <p>Digital multimeter</p> <p>White Picture</p> <p>White Picture</p>	<p> R530, 531</p> <p>PICTURE BRIGHTNESS maximum</p> <p>PICTURE BRIGHTNESS maximum</p>	<p>A BOARD - CONDUCTOR SIDE -</p>  <p>[Check Condition] Step 2 2160 ± 100 μA 120 $^{+2.0}_{-0}$ VAC (Power Supply) 220 $^{+2.0}_{-0}$ VAC (Power Supply) (KV-34V36C only)</p> <p>[Check Condition] Step 4 lower than 22.05 V DC 120 $^{+2.0}_{-0}$ VAC (Power Supply) 220 $^{+2.0}_{-0}$ VAC (Power Supply) (KV-34V36C only)</p> <p>[Check Condition] Step 5 more than 18.0V DC 120 $^{+2.0}_{-0}$ VAC (Power Supply) 220 $^{+2.0}_{-0}$ VAC (Power Supply) (KV-34V36C only)</p>	
			<p>PICTURE BRIGHTNESS maximum</p>  <p>PICTURE BRIGHTNESS maximum</p>	

ADJUSTMENT ITEM AND PROCEDURE	EQUIPMENT AND SIGNAL	MEASUREMENT POSITION	ADJUSTMENT LOCATION	ILLUSTRATION AND SHAPE AND NUMBER
<p>B+ VOLTAGE CONFIRMATION</p> <p>The following adjustments should always be performed when replacing the components marked with <input checked="" type="checkbox"/> on the schematic.</p> <ol style="list-style-type: none"> 1) Supply AC Voltage with a variable auto-transformer. 2) Input an entirely monoscope signal. 3) Set the PICTURE control and the BRIGHTNESS control to initial reset value. 4) Confirm the voltage of the G board CN641 between pin 1 to ground is less than 136.5 VDC. 5) If step 4) is not satisfied, replace the R661 and repeat above steps. 	<p>Variable auto-transformer</p> <p>Monoscope</p>	<p><u>G-Board</u> IC643, R661</p> <p><u>G Board CN641</u> Pin 1 - ground</p>	<p>PICTURE, BRIGHTNESS initial reset</p>	<p>130 ± 0 V AC</p> <p>220 ± 0 V AC (KV-34V36C only)</p>

4-2. FRAME SCHEMATIC DIAGRAM

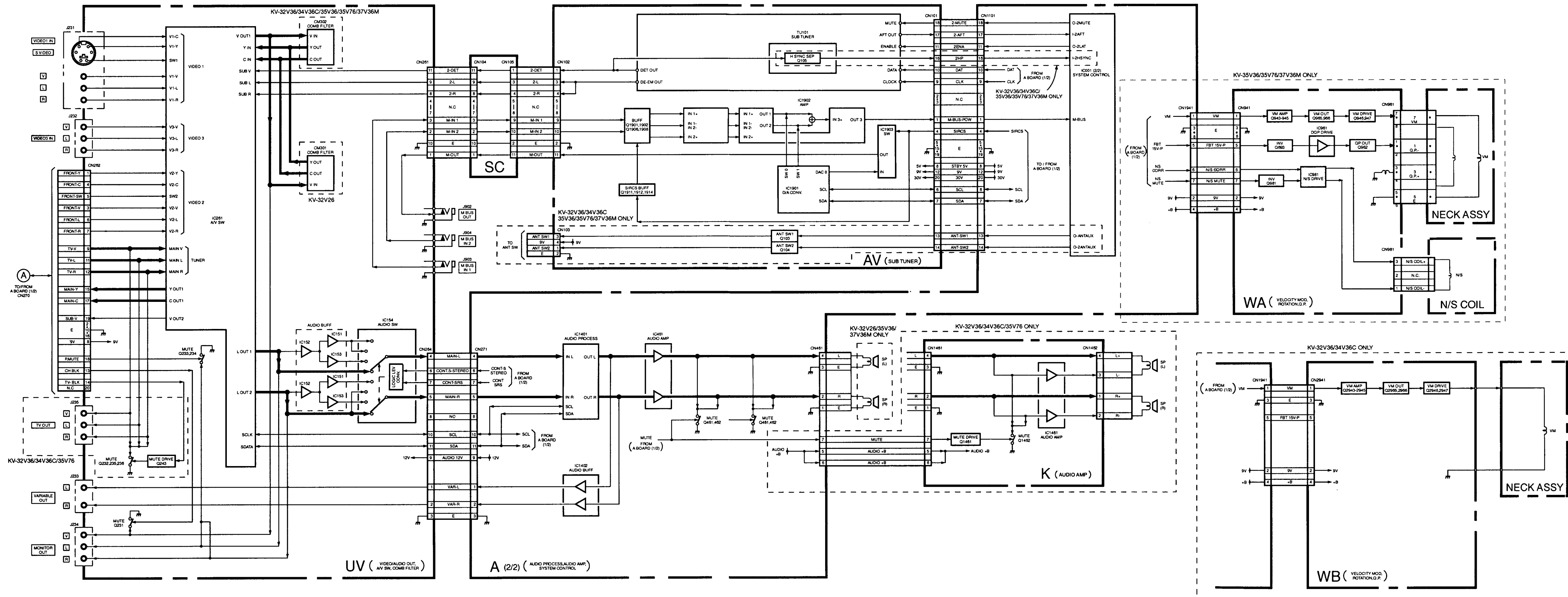

**SECTION 4
DIAGRAMS (continued)**

4-3. CIRCUIT BOARDS LOCATION

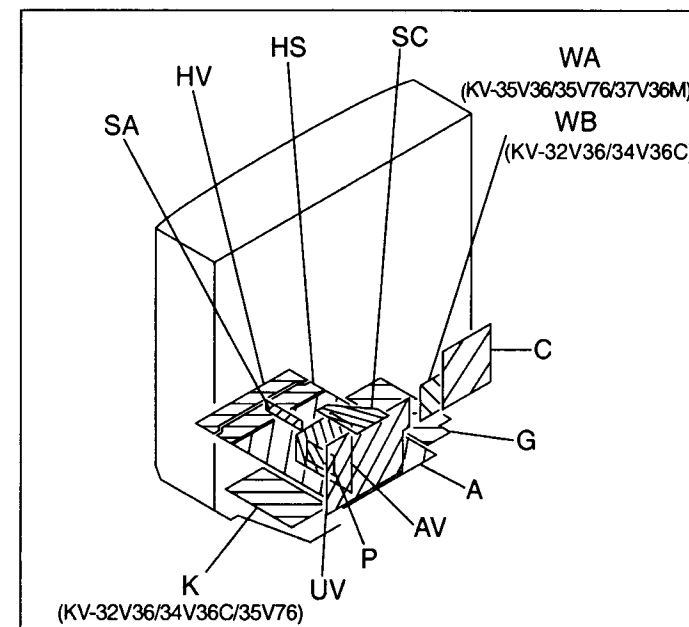

- Readings are taken with a color-bar signal input
- Readings are taken with a 10M Ω digital multimeter
- Voltages are DC with respect to ground unless otherwise noted
- Voltage variations may be noted due to normal production tolerances
- All voltages are in V
- S Measurement impossibility
- B+ line
- B-line
- (Actual measured value may be different)
- signal path (RF)
- Circled numbers are waveform references

Reference information

- RESISTOR**
- RN METAL FILM
 - RC SOLID
 - FPRD NONFLAMMABLE CARBON
 - FUSE NONFLAMMABLE FUSIBLE
 - RW NONFLAMMABLE WIREWOUND
 - RS NONFLAMMABLE METAL OXIDE
 - RB NONFLAMMABLE CEMENT
 - ※ ADJUSTMENT RESISTOR
- COIL**
- LF-8L MICRO INDUCTOR
- CAPACITOR**
- TA TANTALUM
 - PS STYROL
 - PP POLYPROPYLENE
 - PT MYLAR
 - MPS METALIZED POLYESTER
 - MPP METALIZED POLYPROPYLENE
 - ALB BIPOLAR
 - ALT HIGH TEMPERATURE
 - ALR HIGH RIPPLE

4-4. PRINTED WIRING BOARDS AND SCHEMATIC DIAGRAMS

- Note:
- All capacitors are in μ F unless otherwise noted pF μ F 50WV or less are not indicated except for electrolytics and tantalums.
 - All electrolytics are in 50V unless otherwise specified
 - All resistors are in ohms $k\Omega=1000\Omega$, $M\Omega=1000k\Omega$
 - Indication of resistance, which does not have one for rating electrical power, is as follows

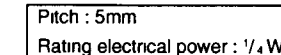

- $1/4W$ in resistance, $1/16W$ and $1/8W$ in chip resistance
- nonflammable resistor
- fusible resistor
- internal component
- panel designation and adjustment for repair
- All variable and adjustable resistors have characteristic curve B, unless otherwise noted

- The components identified by in this basic schematic diagram have been carefully factory-selected for each set in order to satisfy regulations regarding X-ray radiation
- Should replacement be required, replace only with the value originally used
- When replacing components identified by , make the necessary adjustments indicated. If results do not meet the specified value, change the component identified by and repeat the adjustment until the specified value is achieved (Refer to R530 and R531 adjustment on Page 15 - 16)
- When replacing the part in below table, be sure to perform the related adjustment

Part replaced ()	Adjustment ()
IC351, IC501, D519, D520, D521	R530, R531
C531, C532, R387, R529, R530, R531, R532, R333R550, T503.....A BOARD	
IC643, R661.....G BOARD	

Note:

The symbol display is on the component side.
The components identified by shading and mark are critical for safety. Replace only with part number specified.
The symbol indicate fast operating fuse. Replace only with fuse of same rating as marked.

Les composants identifiés par un trame et une marque sont critiques pour la sécurité. Ne les remplacer que par une pièce portant le numéro spécifié.

Le symbole indique une fusible à action rapide. Doit être remplacé par une fusible de même valeur, comme marqué.

P BOARD IC VOLTAGE LIST

IC3301	pin	volt	pin	volt	pin	volt	
	1	GND	20	3.0	13	NC	
	2	NC	21	3.0	14	-3.0	
	3	GND	22	4.7	15	GND	
	4	4.0	23	GND	16	GND	
	5	4.0	24	2.9	17	0.7	
	6	GND	25	9.1	18	0.2	
	7	0.2	IC3302	IN	9	1.1	
	8	0	IC3303	1	GND	20	0.3
	9	1.8	2	3.2	21	5.1	
	10	0.3	3	2.6	22	5.2	
	11	8.2	4	2.3	23	NC	
	12	8.2	5	5.1	24	NC	
	13	3.9	6	GND	25	GND	
	14	3.4	7	0.5	26	NC	
	15	0	8	0	27	GND	
	16	2.8	9	0.8	28	2.9	
	17	NC	10	5.2	29	5.2	
	18	2.5	11	2.1	30	2.6	
	19	3.5	12	0.3	31	4.2	
					32	2.5	

All voltages are in V

P BOARD TRANSISTOR VOLTAGE LIST

	B	C	E
Q3301	5.3	9.1	4.7
Q3305	0.5	GND	1.2
Q3306	0.8	GND	1.4
Q3307	0.6	GND	1.3
Q3308	0	GND	2.8
Q3310	0	5.2	GND
Q3312	0	0	0.8
Q3313	0.8	0.4	GND

All voltages are in V



< COMPONENT SIDE >

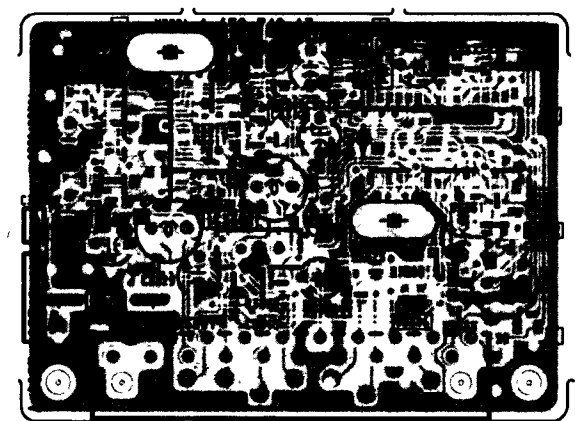

< CONDUCTOR SIDE >

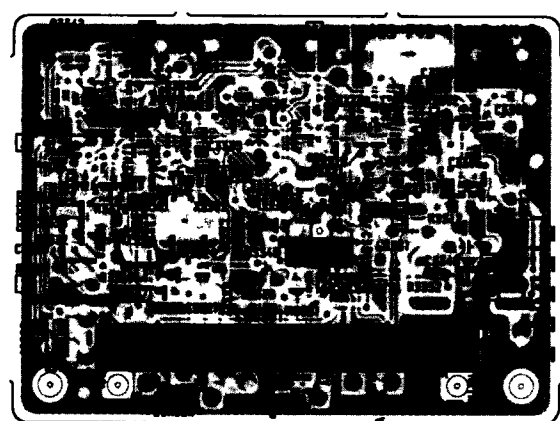

P BOARD WAVEFORMS

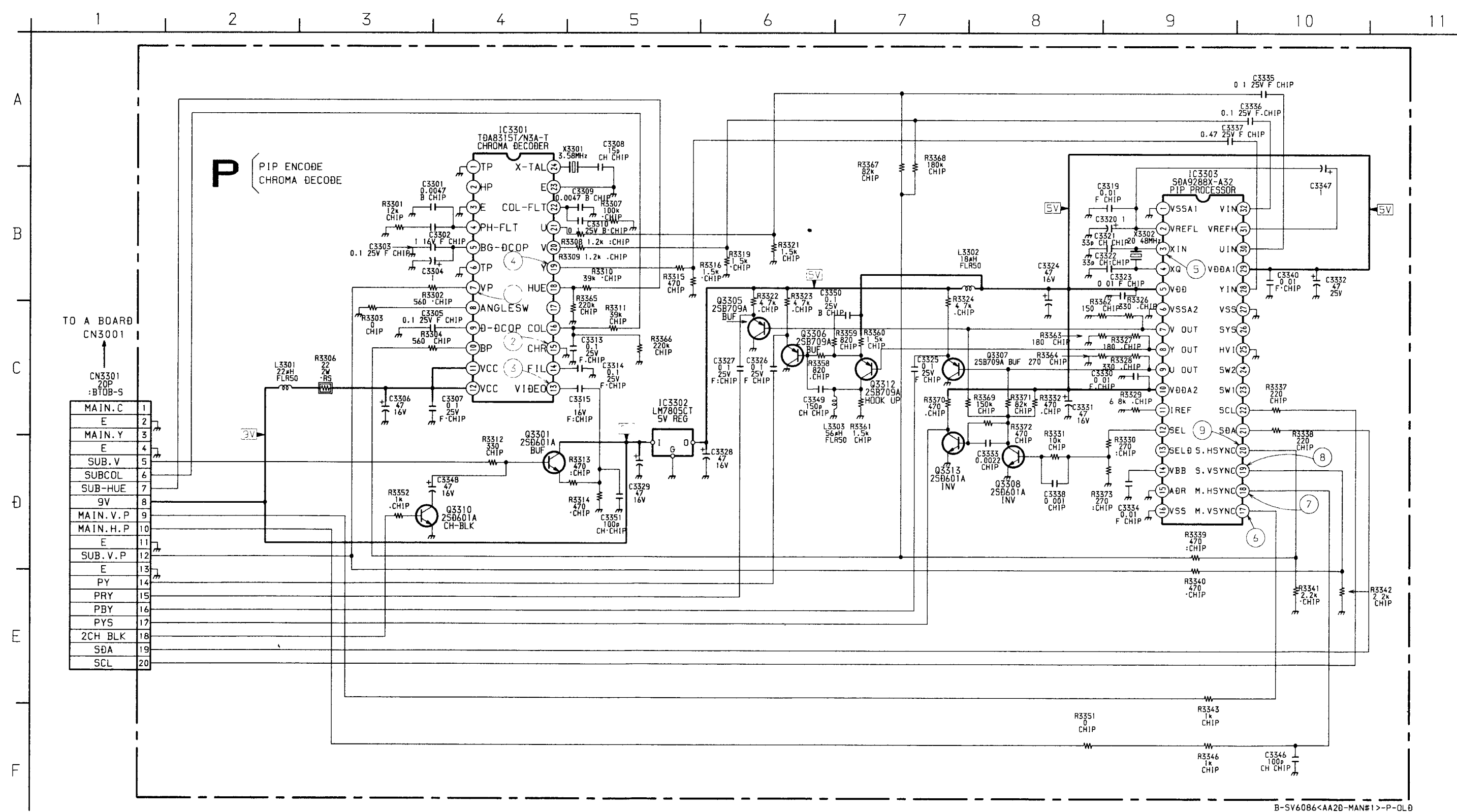
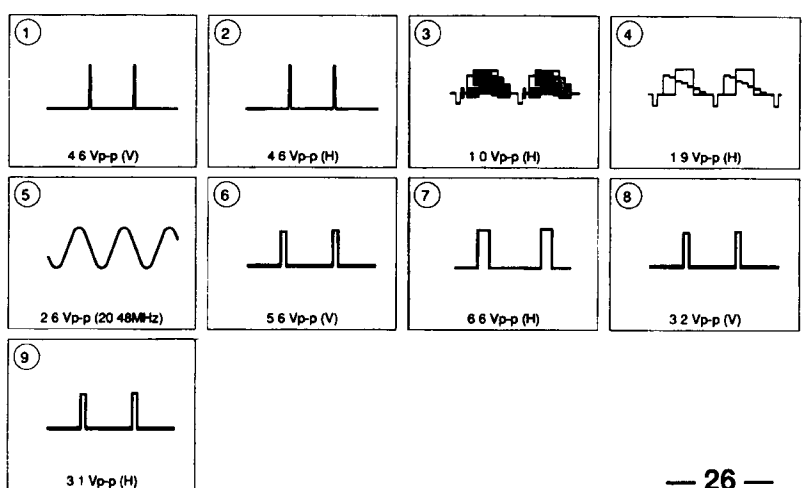

TO A BOARD	CN3001	1	2	3	4	5	6	7	8	9	10	11	12	13	14	15	16	17	18	19	20	
MAIN.C																						
E																						
MAIN.Y																						
E																						
SUB.V																						
SUBCOL																						
SUB-HUE																						
9V																						
MAIN.V.P																						
MAIN.H.P																						
E																						
SUB.V.P																						
E																						
PY																						
PRY																						
PBY																						
PYS																						
2CH_BLK																						
SBA																						
SCL																						

- : Pattern from the side which enables seeing.
- : Pattern of the rear side.

Schematic diagrams

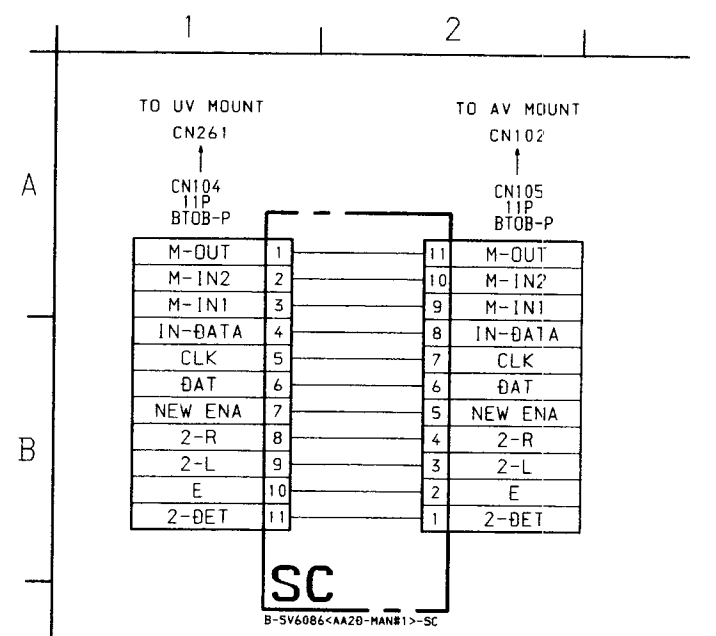
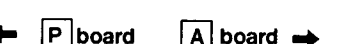

- SC BOARD -

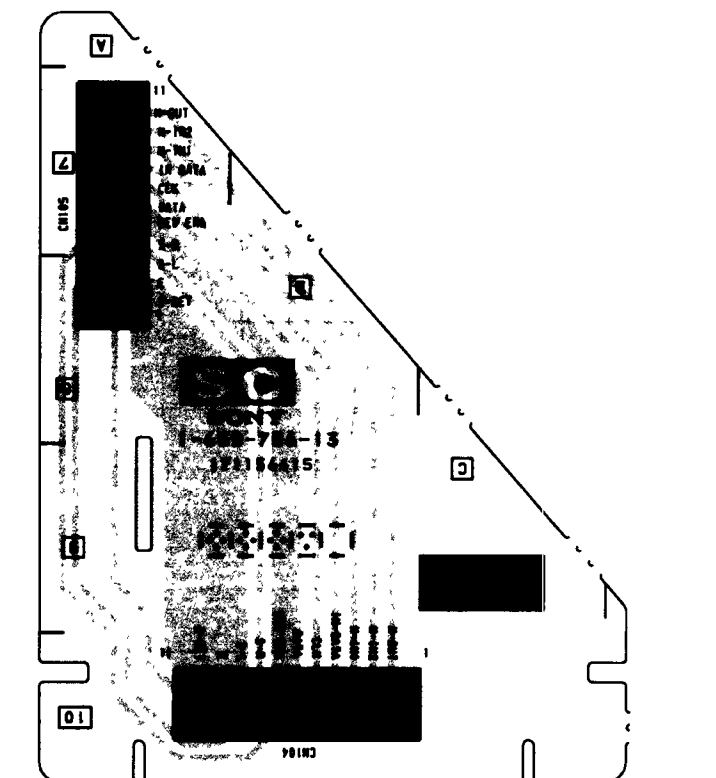

A BOARD: IC1001 CXA1315M

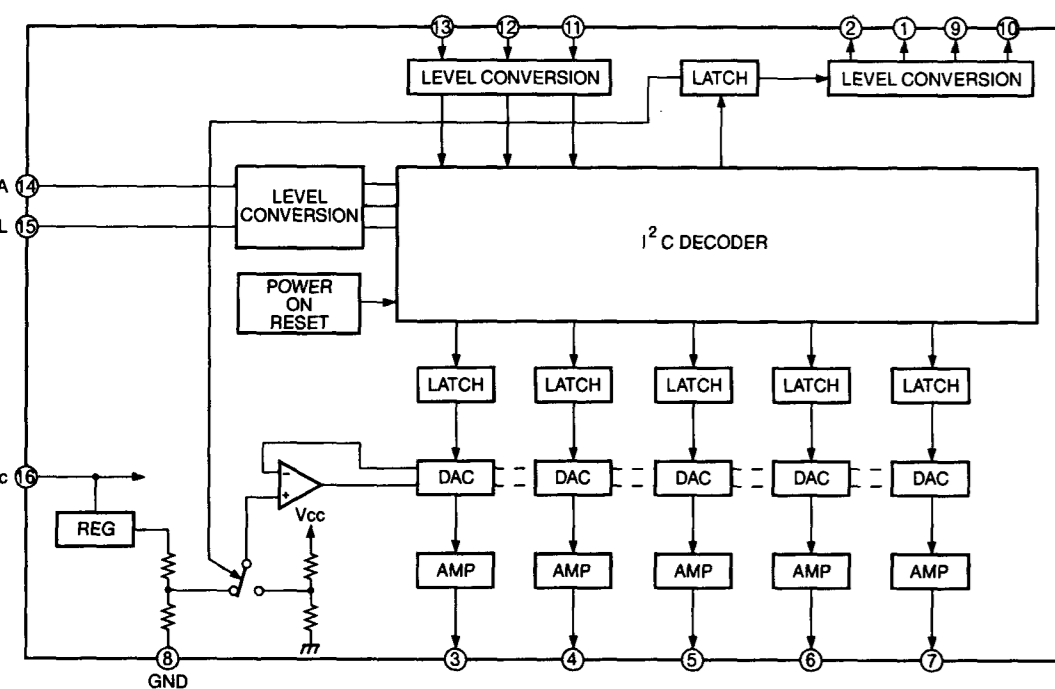

A BOARD: IC1401 BH3856FS

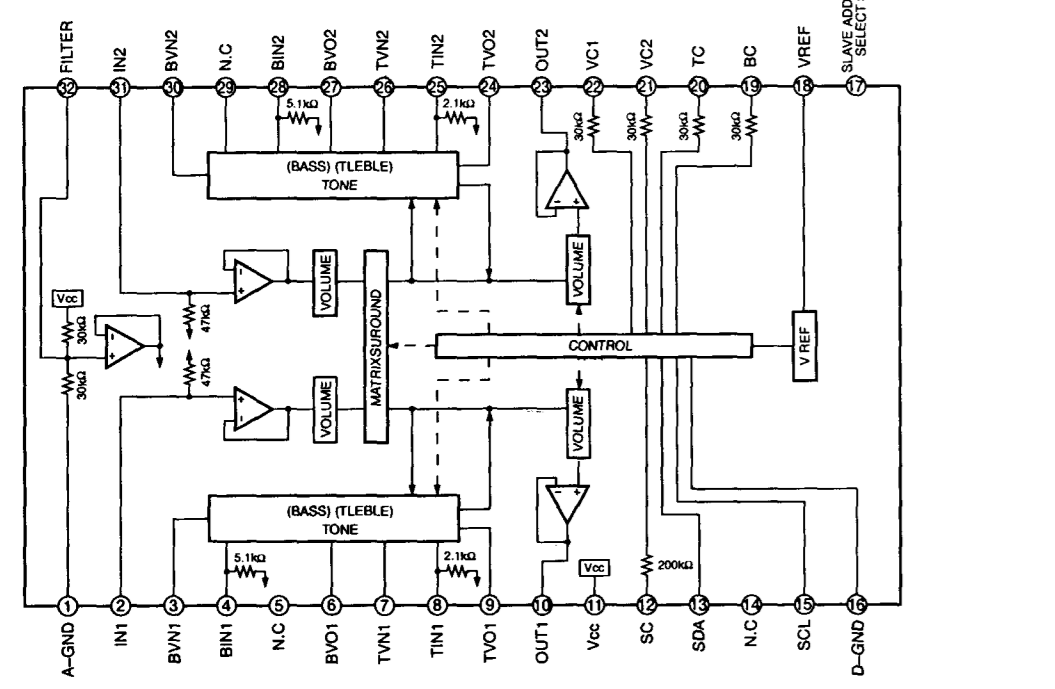

A BOARD: IC461 TDA2009A

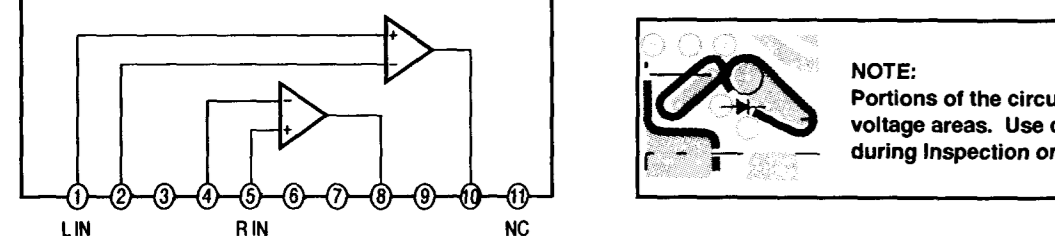

A BOARD: IC1402 NJM4558M

The schematic shows a differential amplifier circuit with two inputs (1, 2) and two outputs (3, 4). The circuit is powered by Vcc and grounded to GND.

NOTE:
Portions of the circuit marked as shown are high voltage areas. Use care to prevent electric shocks during inspection or repair.

A BOARD (35")

A BOARD (35V36/32V36M/35V76)

DIODE	
D001	A-6
D002	D-3
D003	A-6
D004	C-3
D011	A-5
D013	C-5
D014	D-3
D015	C-4
D353	D-8
D356	E-3
D360	E-7
D362	F-8
D368	C-8
D462	F-1
D501	I-3
D502	I-9
D503	I-9
D504	J-9
D505	I-7
D506	I-6
D507	I-3
D515	H-5
D516	I-3
D518	I-4
D519	F-9
D520	H-3
D521	G-3
D530	F-10
D531	F-12
D534	G-9
D535	H-9
D561	G-8
D562	G-3
D1102	B-10
D1103	B-12
D1248	E-12
D1263	D-10
D1264	E-10
IC	
IC001	B-4
IC002	C-3
IC351	D-6
IC461	G-5
IC501	H-3
IC561	G-8
IC1001	D-9
IC1401	E-11
IC1402	E-12
TRANSISTOR	
Q001	A-6
Q002	C-5
Q003	I-2
Q004	I-1
Q010	D-4
Q011	D-4
Q012	D-4
Q013	E-4
Q014	D-4
Q015	D-4
Q016	D-3
Q017	A-5
Q301	D-8
Q302	G-6
Q303	D-8
Q354	E-8
Q356	C-5
Q357	E-5
Q358	F-8
Q461	G-3
Q462	G-4
Q501	J-4
Q502	J-9
Q503	H-3
Q511	H-3
Q512	H-5
Q561	F-7
Q562	F-7
Q563	H-2
Q1102	B-12
Q1103	A-10
Q1231	E-13
Q1232	E-13

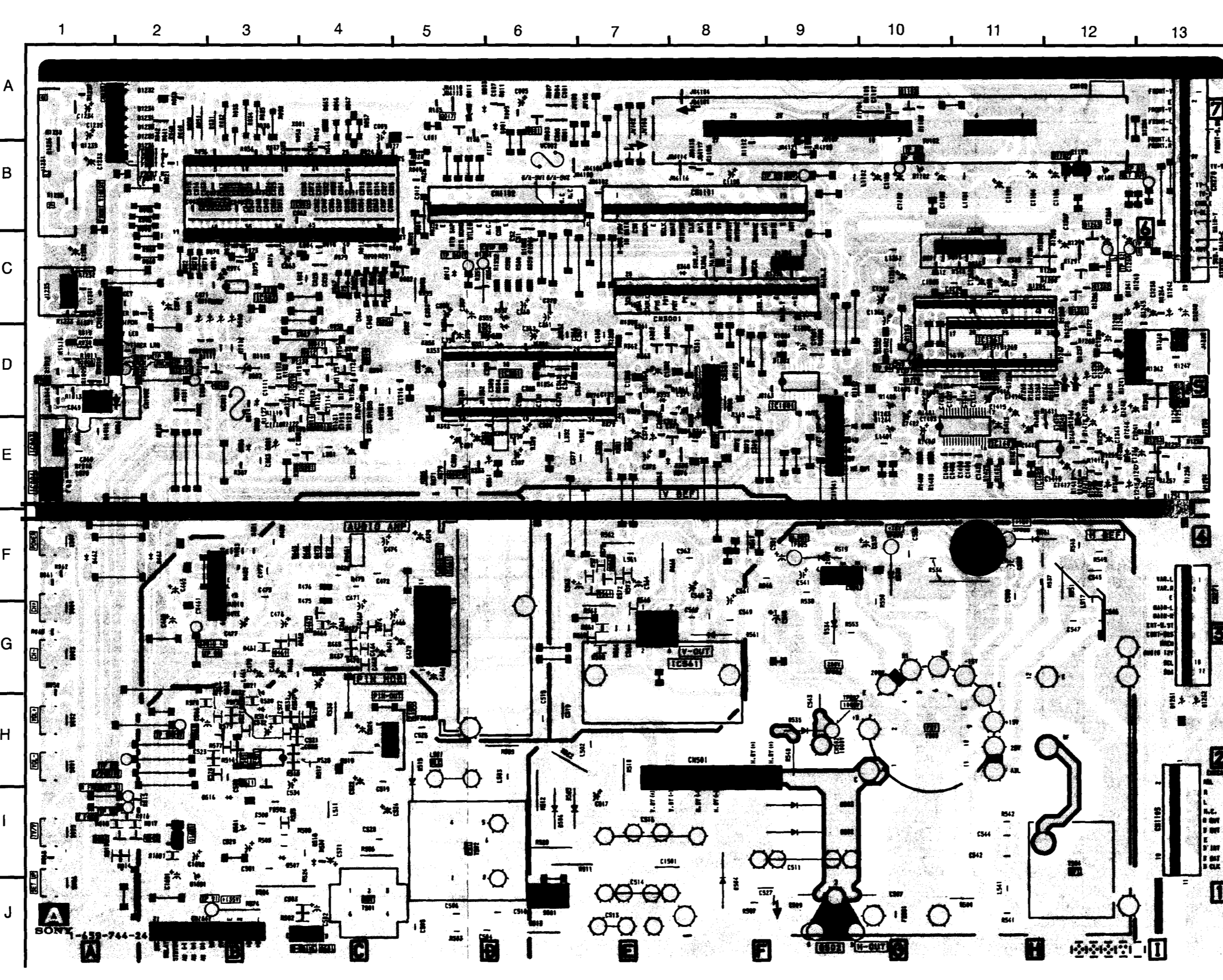

A BOARD (32")

A BOARD (32V26/32V36/34V36C)

DIODE	
D001	A-6
D002	D-3
D003	A-6
D004	C-3
D011	A-5
D013	C-5
D014	D-3
D015	C-4
D353	D-7
D356	E-3
D360	E-7
D362	F-8
D368	C-8
D462	F-1
D501	I-3
D502	I-9
D503	I-9
D504	J-8
D505	I-7
D506	I-6
D507	I-3
D515	H-5
D516	I-3
D518	I-4
D519	F-9
D520	H-3
D521	H-3
D530	F-10
D531	F-12
D534	G-9
D561	G-8
D562	G-3
D1102	B-10
D1103	B-12
D1248	F-12
D1263	D-10
D1264	E-10
IC	
IC001	B-4
IC002	C-3
IC351	D-6
IC461	F-5
IC501	H-3
IC561	G-8
IC1001	D-9
IC1401	E-11
IC1402	E-12
TRANSISTOR	
Q001	A-5
Q002	C-5
Q003	I-2
Q004	I-2
Q010	D-4
Q011	D-4
Q012	D-4
Q013	D-4
Q014	D-4
Q015	D-4
Q016	D-3
Q017	A-5
Q301	D-8
Q302	D-8
Q303	D-7
Q354	E-8
Q356	C-5
Q357	C-5
Q358	F-8
Q461	G-3
Q462	G-4
Q501	J-4
Q502	J-9
Q503	H-3
Q511	H-3
Q512	H-4
Q561	F-7
Q562	F-7
Q563	H-2
Q1102	B-12
Q1103	A-10
Q1231	E-13
Q1232	E-13

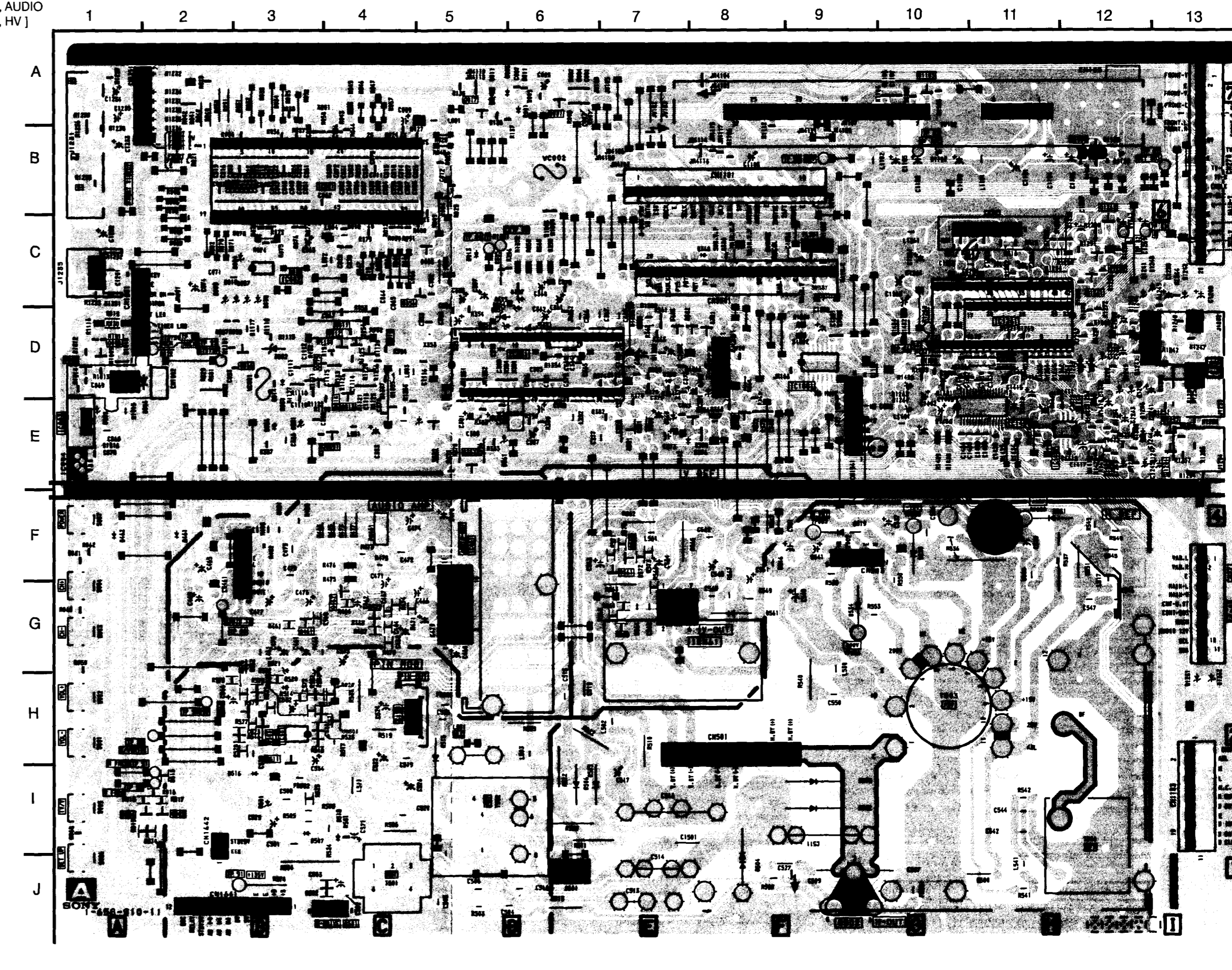

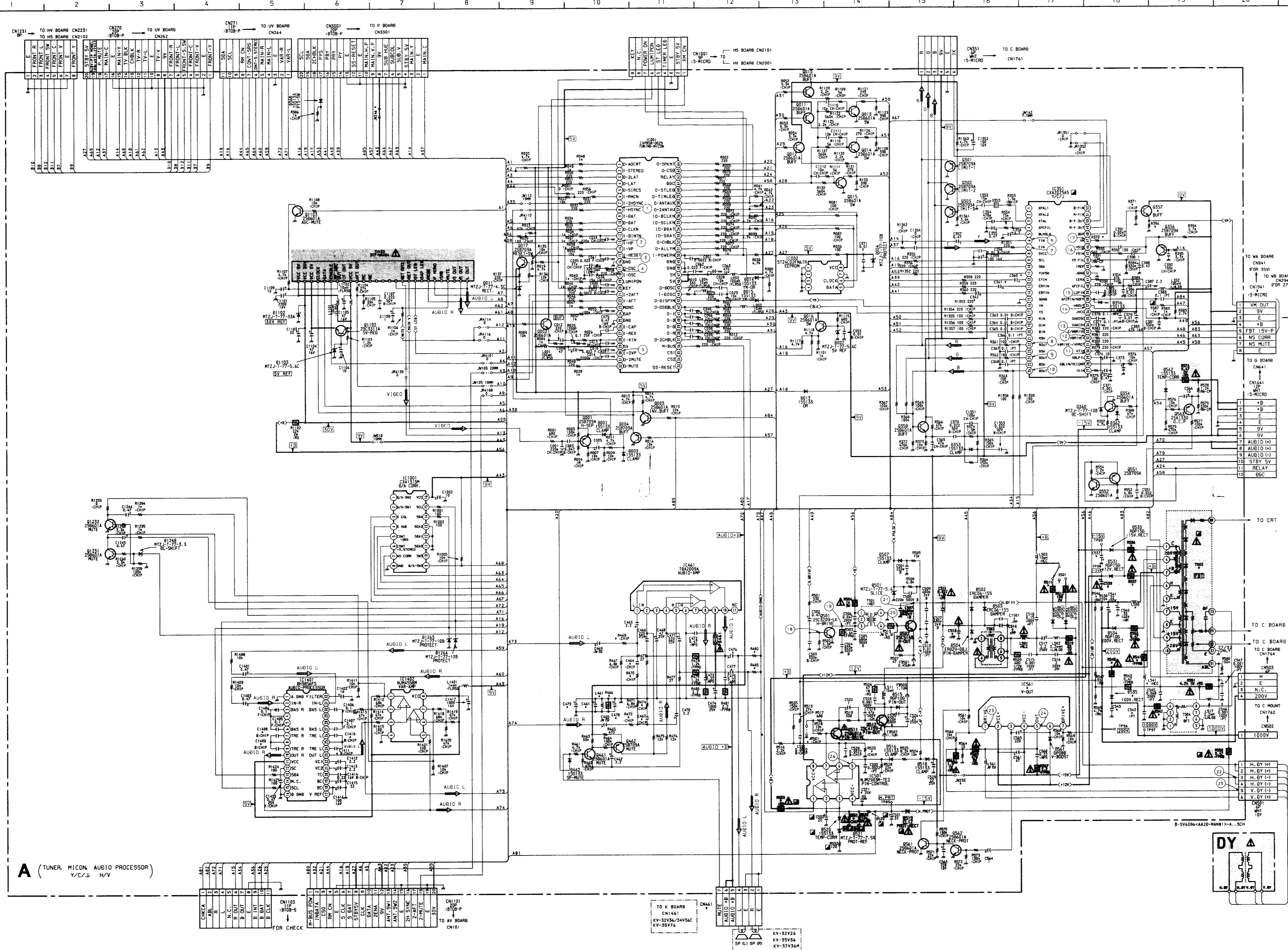

A BOARD MARK LIST

Part No.	QTY	Part No.	QTY	Part No.	QTY	Part No.	QTY
C461	10	33/25V	10	10			
C464	#	0.0047	#	#			
C467	#	0.0047	#	#			
C476	1000/25V	JW (5)	1000/25V	JW (5)			
C477	1000/25V	JW (5)	1000/25V	JW (5)			
C478	#	220/16V	22	220 16V			
C479	#	#	2.2	10			
C513	056/400V	056/400V	033/630V	033/630V			
C514	82/200V	82/200V	82/200V	82/200V			
C537	470/25V	470/25V	1000/25V	1000/25V			
C538	470/16V	470/16V	1000/25V	1000/25V			
C542	#	#	047/200V	047/200V			
C543	#	#	220p/2kV	220p/2kV			
C571	4.7	4.7	#	#			
C1408	0.022	0.033	0.022	0.022			
C1409	0.022	0.033	0.022	0.022			
C1410	0.022	0.033	0.022	0.022			
C1411	0.022	0.033	0.022	0.022			
C1501	12/200V	12/200V	#	#			
CN461	4P	7P	4P	7P			
CN502	#	#	1P	1P			
CN1941	#	5P	8P	8P			
D535	#	#	RGPO2-17	RGPO2-17			
IC561	TDAB172	TDAB172	STV9379	STV9379			
JW501	0	0	0	0			
JW233	12.5MM	12.5MM	#	#			
JW246	5MM	5MM	#	#			
L461	15uH	56uH	220uH	180uH			
L530	JW(5)	JW(5)	#	#			
L541	#	#	10mH	10mH			
Q357	#	2SD601A	2SD601A	2SD601A			
R370	#	1k	1k	1k			
R371	#	1.5k	1.5k	1.5k			
R396	#	1k	1k	1k			
R466	2.2	2.2	#	#			
R469	1.8k	5.6k	2.2k	5.6k			
R470	#	2.2k	#	#			
R472	1.8k	5.6k	2.2k	5.6k			
R474	#	15k	#	#			
R482	2.2k	#	2.2k	#			
R483	2.2k	#	2.2k	#			
R511	68/2W	68/2W	100/2W	100/2W			
R523	10k	10k	8.2k	8.2k			
R529	22k	22k	18k	18k			
R531	68k	68k	220k	220k			
R533	47k	33k	33k	33k			
R536	47/5W	47/5W	4.7/3W	4.7/3W			
R537	47/5W	47/5W	18/3W	18/3W			
R541	#	#	0.47	0.47			
R542	#	#	2.2	2.2			
R546	22k	22k	1.5k	1.5k			
R548	#	#	3.3k/1W	3.3k/1W			
T502	400UH	400UH	500UH	500UH			
T503	NX-A2609	NX-A2609	NX-3001	NX-3001			
T504	#	#	DFT	DFT			

A BOARD IC VOLTAGE LIST

IC	Pin	Volt	Pin	Volt	Pin	Volt	Pin	Volt	
IC001	1	0	52	0	31	3.1	6	0.6	
	2	0	53	4.9	32	3.2	7	3.8	
	3	0	54	4.9	33	3.7	8	GND	
	4	0	55	4.9	34	4.5	9	0	
	5	0	56	5.0	35	4.8	10	0	
	6	5.0	57	5.0	36	8.7	11	GND	
	7	0	58	0	37	3.4	12	GND	
	8	0	59	3.7	38	3.6	13	GND	
	9	0.8	60	0.5	39	4.1	14	5.0	
	10	0	61	0	40	4.3	15	5	
	11	0	62	4.8	41	2.5	16	8.7	
IC002	12	5	63	0	42	GND	1	GND	
	13	4.2	64	4.8	43	2.9	2	4.3	
	14	1.3	65	0	44	2.8	3	4.3	
	15	5	66	0	45	4.1	4	4.3	
	16	GND	3	GND	46	3.3	5	0	
	17	2.6	4	GND	47	6.0	6	4.3	
	18	*	5	5.0	48	0.4	7	4.3	
	19	3.1	6	5.0	49	0	8	4.4	
	20	5	7	GND	50	0	9	4.4	
	21	2	8	5.0	51	1.5	10	4.4	
	22	2	1	NC	2	3.5	11	8.7	
IC351	23	0	2	NC	3	12.2	12	3.8	
	24	0	3	2.2	4	3.5	13	4.9	
	25	GND	4	5.9	5	1.5	14	0	
	26	0	5	4.1	6	0	15	5	
	27	1.6	6	4.6	7	0	16	0	
	28	5	7	4.3	8	0.3	17	4	
	29	0.2	8	2.2	9	2.2	18	4	
	30	0	9	5.2	10	0.3	19	2	
	31	0	10	5.2	11	0	20	2	
	32	0	11	0.3	IC501	1	3.4	21	0
	33	0	12	6.6	2	7.9	22	0	
34	0	13	6.3	3	8.3	23	4.3		
35	0	14	6.3	4	-16.5	24	4.3		
36	0	15	GND	5	2.3	25	4.3		
37	0	16	0	6	2.8	26	4.3		
38	0	17	0	7	-16.3	27	4.3		
39	0	18	5.2	8	12.6	28	4.3		
40	0	19	5.2	IC561	1	1.6	29	0	
41	0	20	5.2	2	12.6	30	4.3		
42	0	21	4.0	3	-14.5	31	4.3		
43	0	22	2.2	4	-16.6	32	5.6		
44	3.0	23	5.1	5	0.0	33	4.2		
45	3.0	24	1.8	6	1.8	34	4.3		
46	5.0	25	4.5	7	1.5	35	4.3		
47	5.0	26	2.3	IC1001	1	0.0	4	GND	
48	GND	27	4.7	2	0.0	5	4.3		
49	GND	28	1.7	3	3.2	6	4.3		
50	5.0	29	6.8	4	2.8	7	4.3		
51	0	30	0.7	5	0.5	8	8.7		

A BOARD TRANSISTOR VOLTAGE LIST

QTY	Part No.	Volt	C	E
Q001	5.2	0.9	5.0	
Q002	4.8	5.0	4.1	
Q003	-0.4	4.2	GND	
Q004	0.8	GND	1.3	
Q010	0	8.7	0	
Q011	0	8.7	0	
Q012	0	8.7	0	
Q013	-0.2	0	GND	
Q014	-0.2	0	GND	
Q015	-0.2	0	GND	
Q016	5.8	8.7	5.1	
Q017	4.4	5.0	5.0	
Q301	4.0	GND	2.2	
Q302	4.0	GND	1.8	
Q303	4.0	GND	2.0	
Q354	0.2	GND	-0.5	
Q365	4.9	GND	5.8	
Q357	3.6	8.7	0	
Q358	1.9	8.7	2.0	
Q461	0.8	0	0	
Q462	20.0	20.6	20.7	
Q501	-0.7	105.6	GND	
Q502	-0.4	136.1	0	
Q503	0	8.3	GND	
Q511	-16.3	-13.0	-16.5	
Q512	-16.9	18.1	-16	
Q563	134.3	0.4	134.9	
Q1102	6.0	9.2	5.3	
Q1103	0	2.5	GND	
Q1231	0	0	GND	
Q1232	0	0	GND	

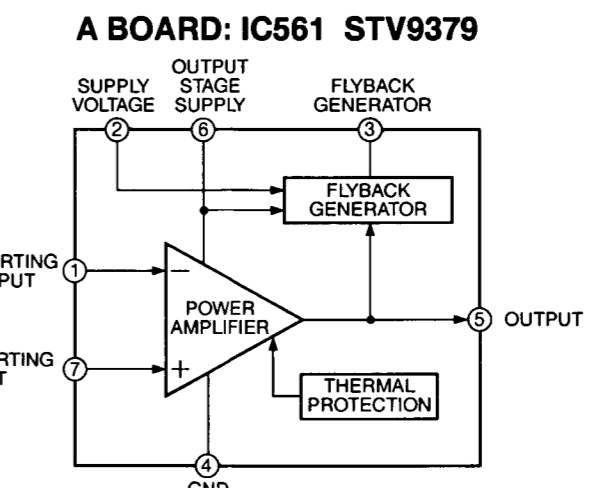
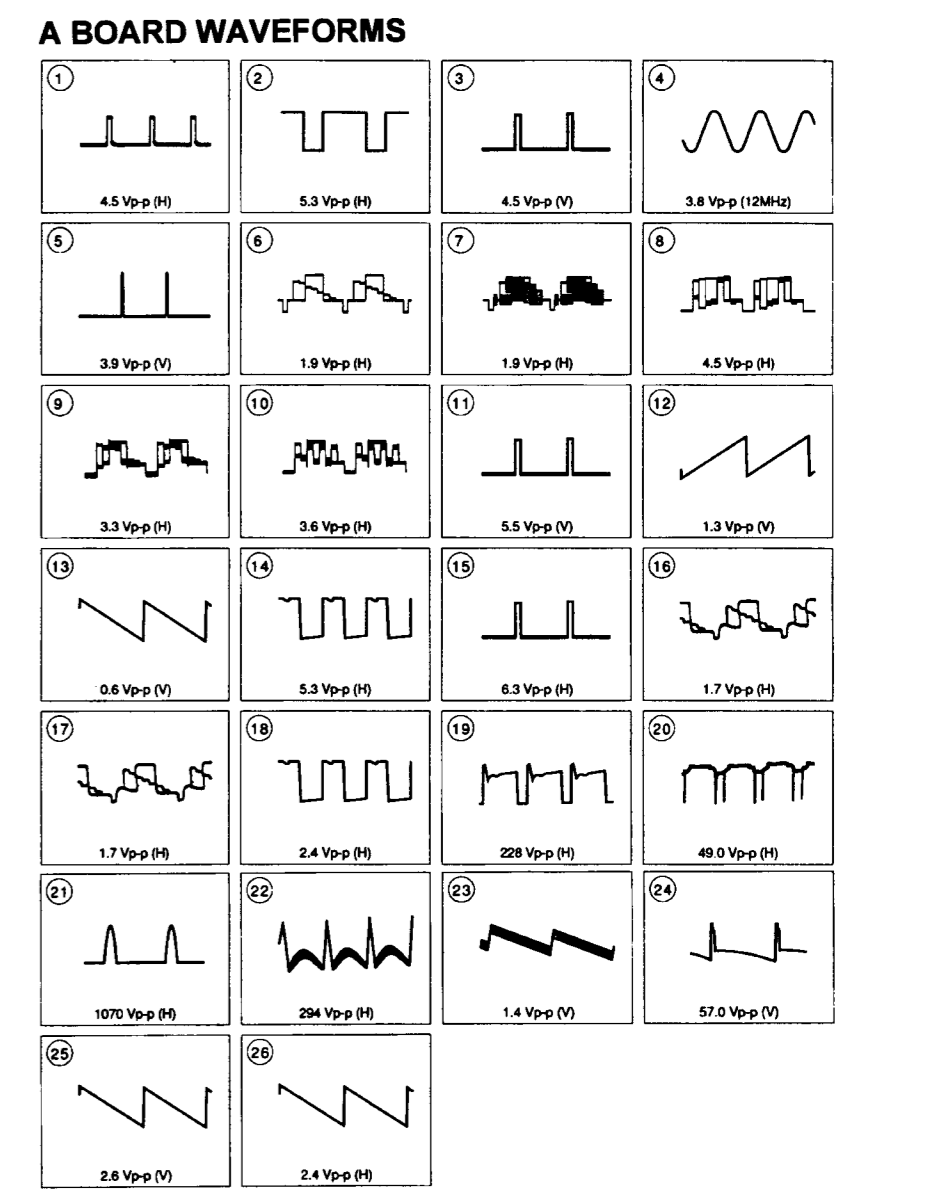

UV BOARD: IC154 CD4052BCN

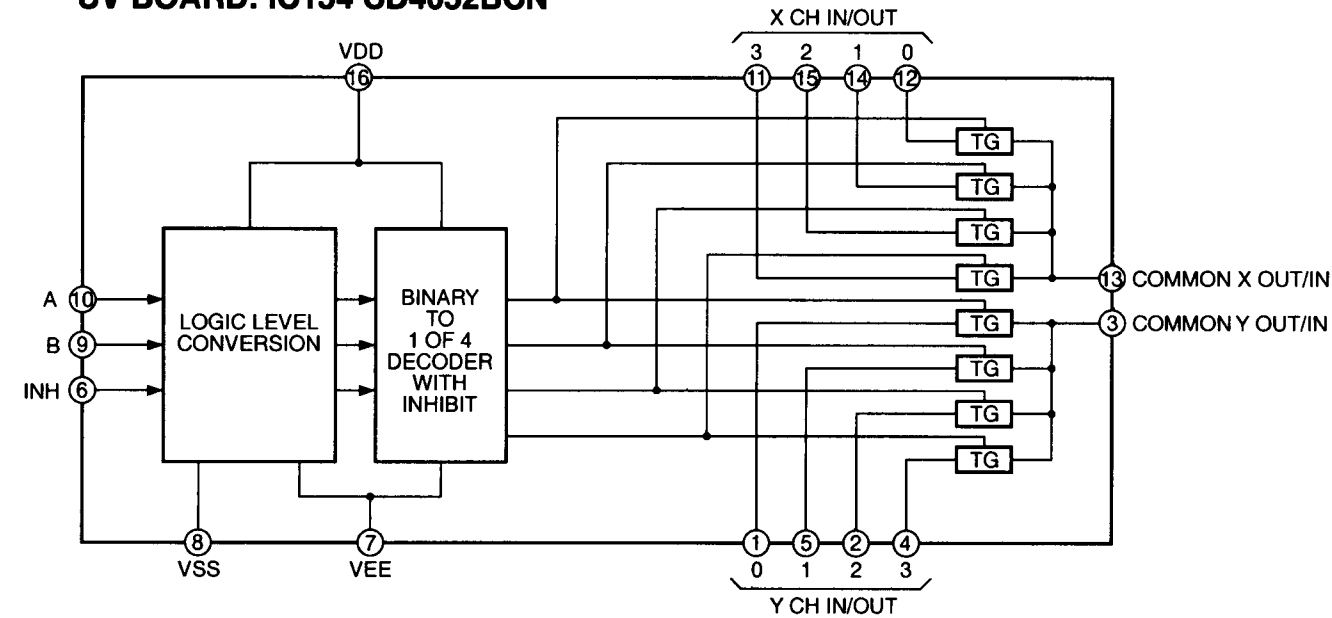

UV BOARD IC261MM1311AD

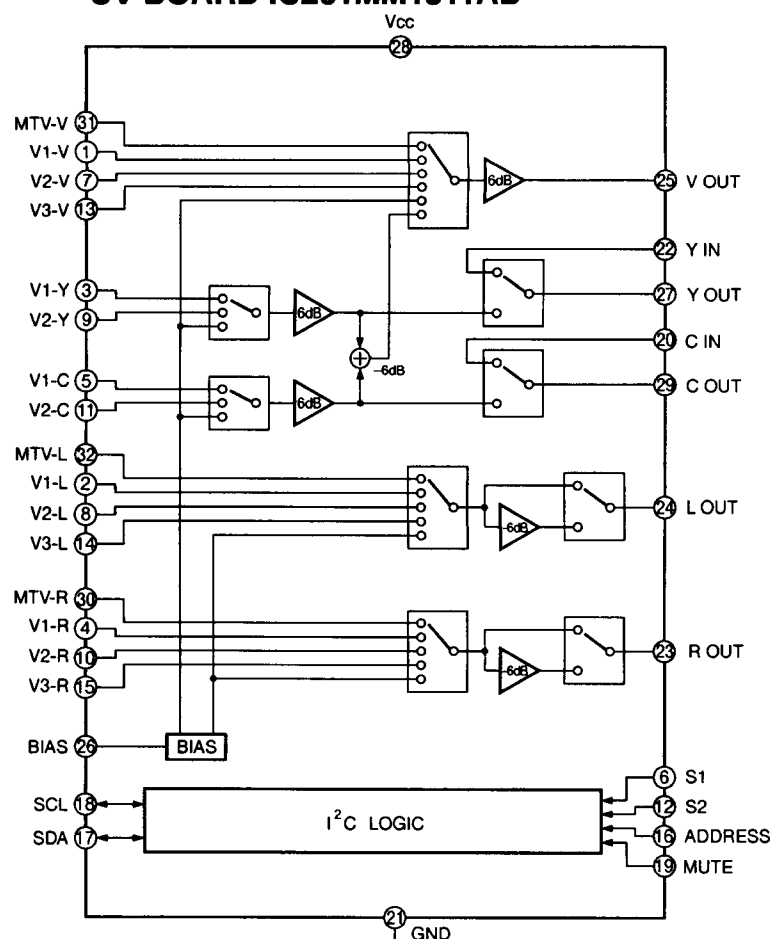

UV BOARD* MARK LIST

	32V26	36V36/37V36M	34V36C/32V36/35V76
C245	#	#	470 25V
C246	#	#	0 47
C247	#	#	0 47
C261	#	0 047 MPS	0 047 MPS
C266	#	1	1
C267	#	1	1
C302	#	470 16V	470 16V
CM301	1-467-554-21	#	#
CM302	#	1-467-656-11	1-467-656-11
D239	#	#	MTZJ-T-77-3 3
D245	#	#	MTZJ-T-77-3 3
D246	#	#	MTZJ-T-77-3 3
J235	#	#	1-750-517-11 3P
Q232	#	#	2SD601A
Q235	#	#	2SD601A
Q236	#	#	2SD601A
Q240	#	#	2SB709A
Q241	#	#	2SB709A
Q242	#	#	2SB709A
Q261	#	#	2SD601A
R206	#	1k	1k
R207	#	#	0
R208	#	#	1k
R209	#	#	6 8k
R210	#	#	6 8k
R219	#	#	4 7k
R220	#	#	4 7k
R221	#	#	470
R222	#	#	100
R223	#	#	2400 00.00
R224	#	#	100
R252	#	#	56
R253	#	#	470k
R254	#	#	470k
R255	#	#	470k
R258	#	#	6 8k
R266	#	#	560
R267	#	#	680
R275	#	#	4 7k
R276	#	#	4 7k
R278	#	#	470

NOT MOUNTED

UV BOARD TRANSISTOR VOLTAGE LIST

	B	C	E
Q231	0	5.7	GND
Q232	0	4.9	GND
Q234	0	0	GND
Q235	0	0	GND
Q236	0	0	GND
Q237	5.0	GND	5.7
Q238	4.1	GND	4.7
Q239	4.1	GND	4.7
Q240	4.4	GND	5.0
Q241	4.4	GND	5.0
Q242	4.3	GND	4.9
Q243	0.2	GND	0.9
Q261	4.6	8.7	4.0
Q262	4.9	5.7	4.2
Q263	3.4	GND	4.1
Q265	4.3	GND	4.9

All voltages are in V

UV BOARD IC VOLTAGE LIST

IC	pin	volt	pin	volt
IC151	1	4.4	12	4.4
	2	4.4	13	4.4
	3	4.4	14	4.4
	4	8.7	15	4.4
	5	4.4	16	8.7
	6	4.4	1	4.8
	7	4.4	2	4.2
	8	4.4	3	4.8
	9	4.4	4	4.2
	10	4.4	5	4.8
	11	GND	6	4.5
	12	4.4	7	4.8
	13	4.4	8	4.2
	14	4.4	9	4.8
IC152	1	4.4	10	4.2
	2	4.4	11	4.9
	3	4.4	12	5.8
	4	8.7	13	4.8
	5	4.4	14	4.2
	6	4.4	15	0
	7	4.4	16	4.2
	8	4.4	17	5.8
	9	4.4	18	NC
	10	4.4	19	5.0
	11	GND	20	0
IC153	1	4.4	21	GND
	2	4.4	22	NC
	3	4.4	23	6.7
	4	GND	24	NC
	5	4.4	25	4.2
	6	4.4	26	4.2
	7	4.4	27	6.1
	8	GND	28	NC
IC154	1	4.4	29	4.8
	2	4.4	30	GND
	3	4.4	31	5.6
	4	4.4	32	4.1
	5	4.4	33	4.1
	6	4.4	34	5.0
	7	4.4	35	NC
	8	GND	36	4.2
	9	GND	37	4.3
	10	0.5	38	8.7
	11	4.4	39	3.4

All voltages are in V

UV BOARD WAVEFORMS

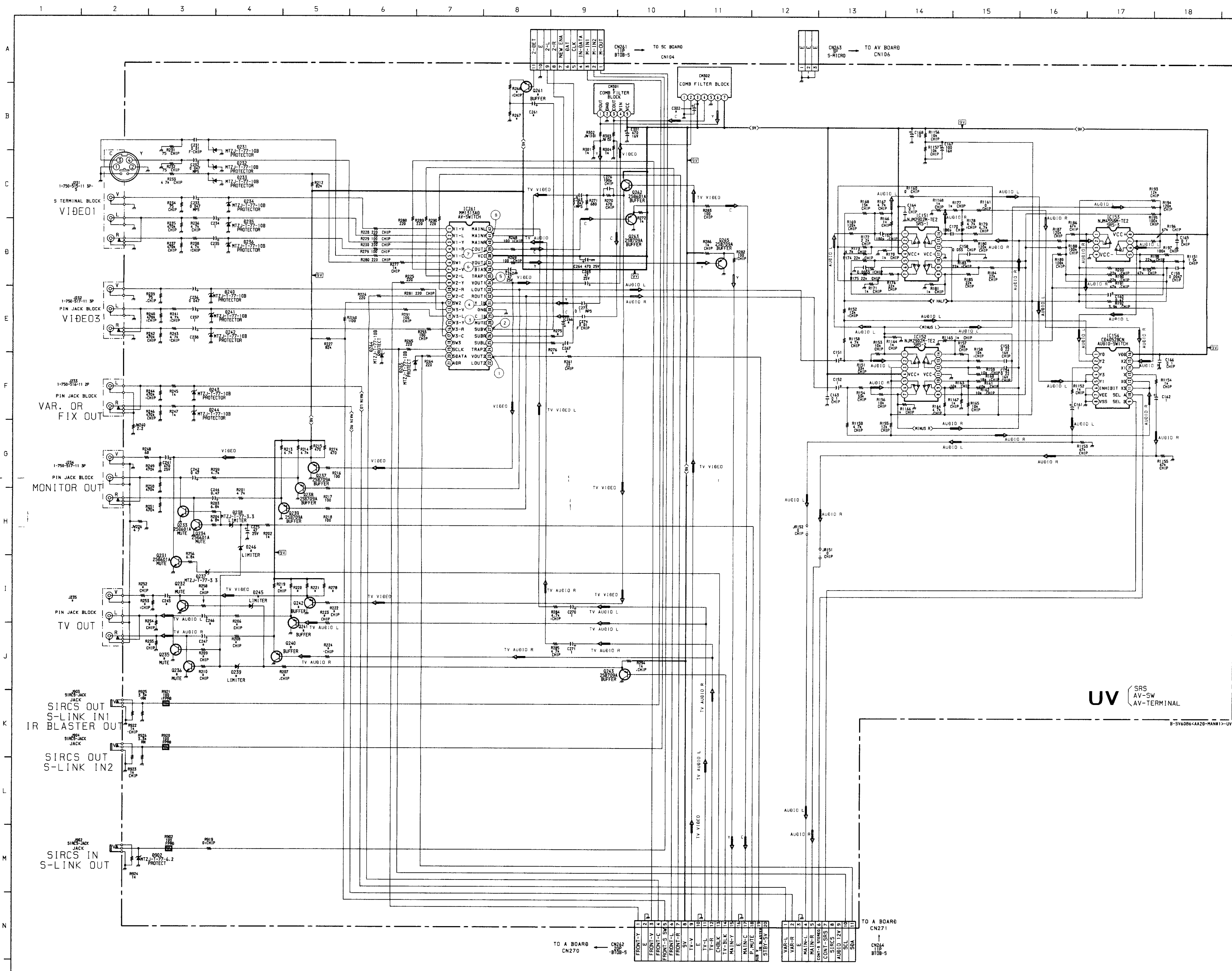
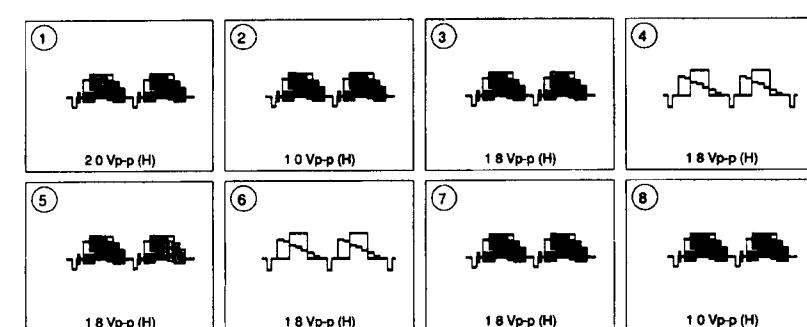

UV SRS AV-SW AV-TERMINAL

— UV BOARD —

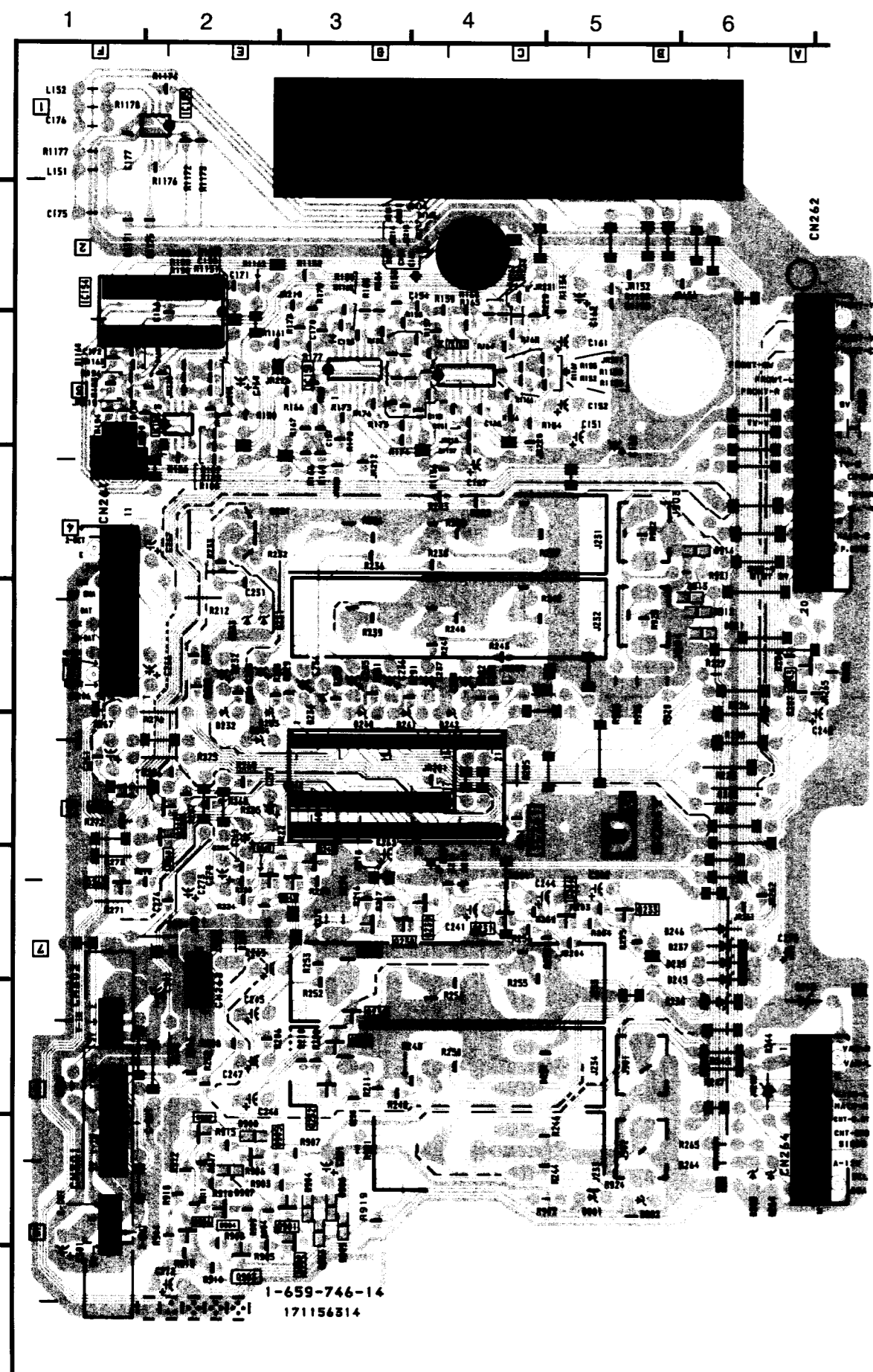

UV BOARD

DIODE	
D231	E-2
D232	E-2
D233	E-2
D234	F-2
D235	E-2
D236	E-3
D237	G-6
D238	G-6
D239	G-6
D240	E-3
D241	E-3
D242	E-4
D243	G-6
D244	H-6
D245	G-6
D246	G-6
D264	I-6
D265	I-6
D902	I-5
D909	E-5
D910	E-5

IC	
IC151	C-3
IC152	C-4
IC153	C-2
IC154	C-2
IC261	F-4

TRANSISTOR	
Q231	G-4
Q232	H-3
Q233	G-5
Q234	G-5
Q235	H-3
Q236	H-3
Q237	G-3
Q238	G-3
Q239	G-4
Q240	G-2
Q241	G-3
Q242	G-3
Q243	E-6
Q261	F-1
Q262	G-1
Q263	F-2
Q265	F-2

— WA BOARD —

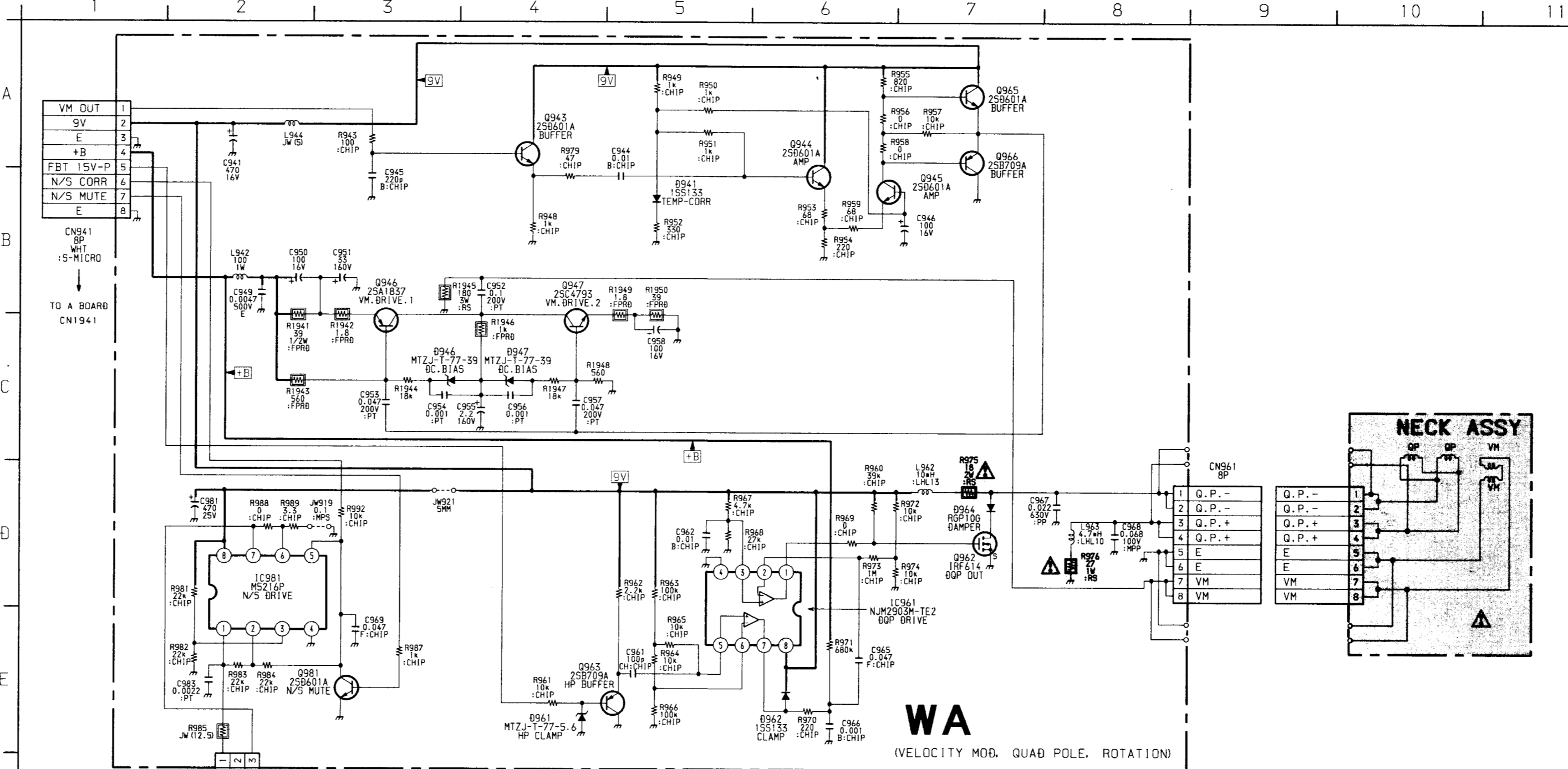
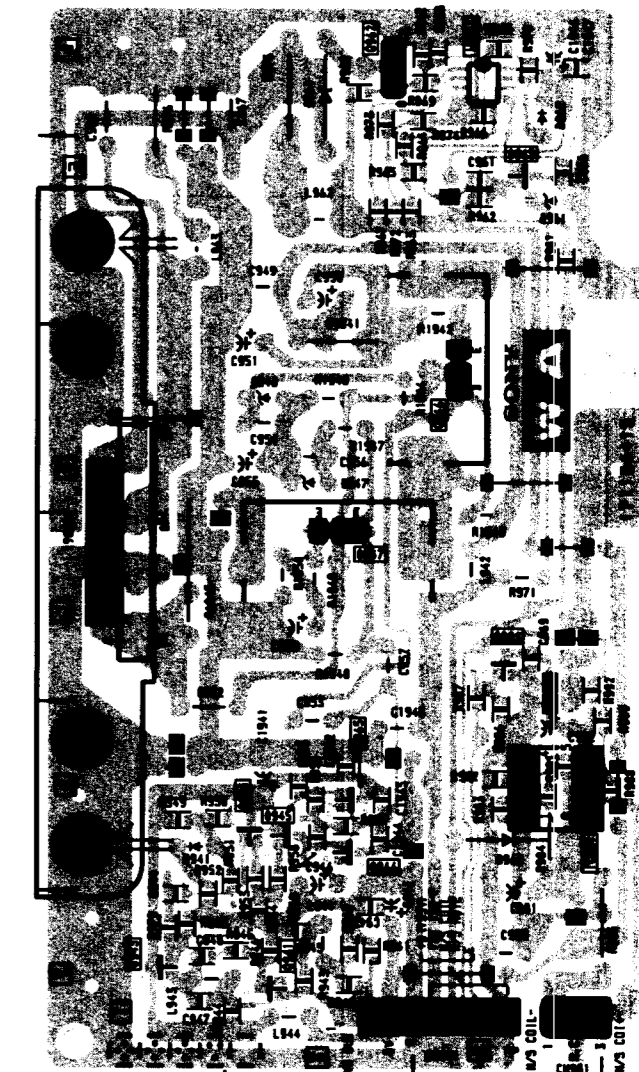

WA
(VELOCITY MOD., QUAD POLE, ROTATION)
B-5V6086<AA2B-MAN#1>-WA.

WA BOARD IC VOLTAGE LIST

IC961	pin	volt	IC981	pin	volt
	1	4.3		1	4.8
	2	4.1		2	4.5
	3	7.5		3	4.4
	4	GND		4	GND
	5	4.6		5	4.1
	6	4.2		6	4.1
	7	4.4		7	4.4
	8	8.7		8	8.7

All voltages are in V

WA BOARD TRANSISTOR VOLTAGE LIST

	B	C	E
Q943	3	8.7	2.4
Q944	2.7	8.7	2.1
Q945	2.7	5.5	2.1
Q946	134	65.7	134.6
Q947	0.9	65.7	0.5
Q963	4.6	GND	5.3
Q965	5.5	8.7	5.5
Q966	5.5	GND	5.5
Q981	0	4.1	GND
	G	D	S
Q962	4.3	9.8	GND

All voltages are in V

WA BOARD: IC981 M5216P

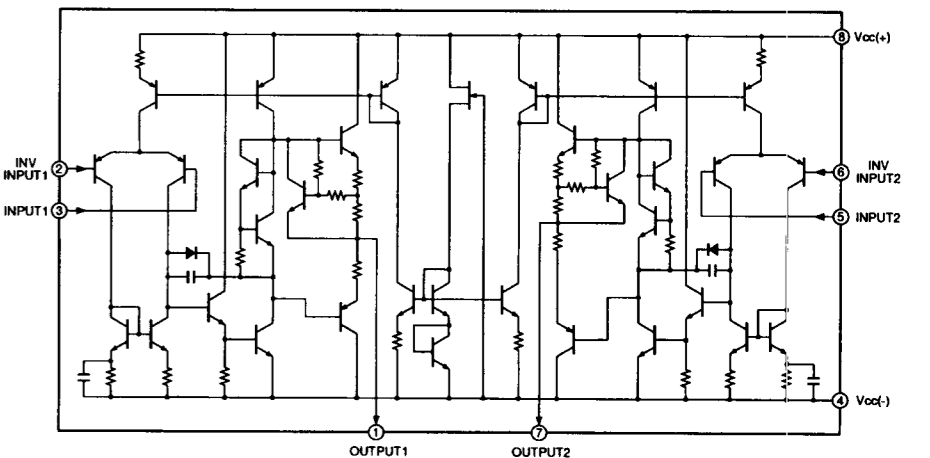

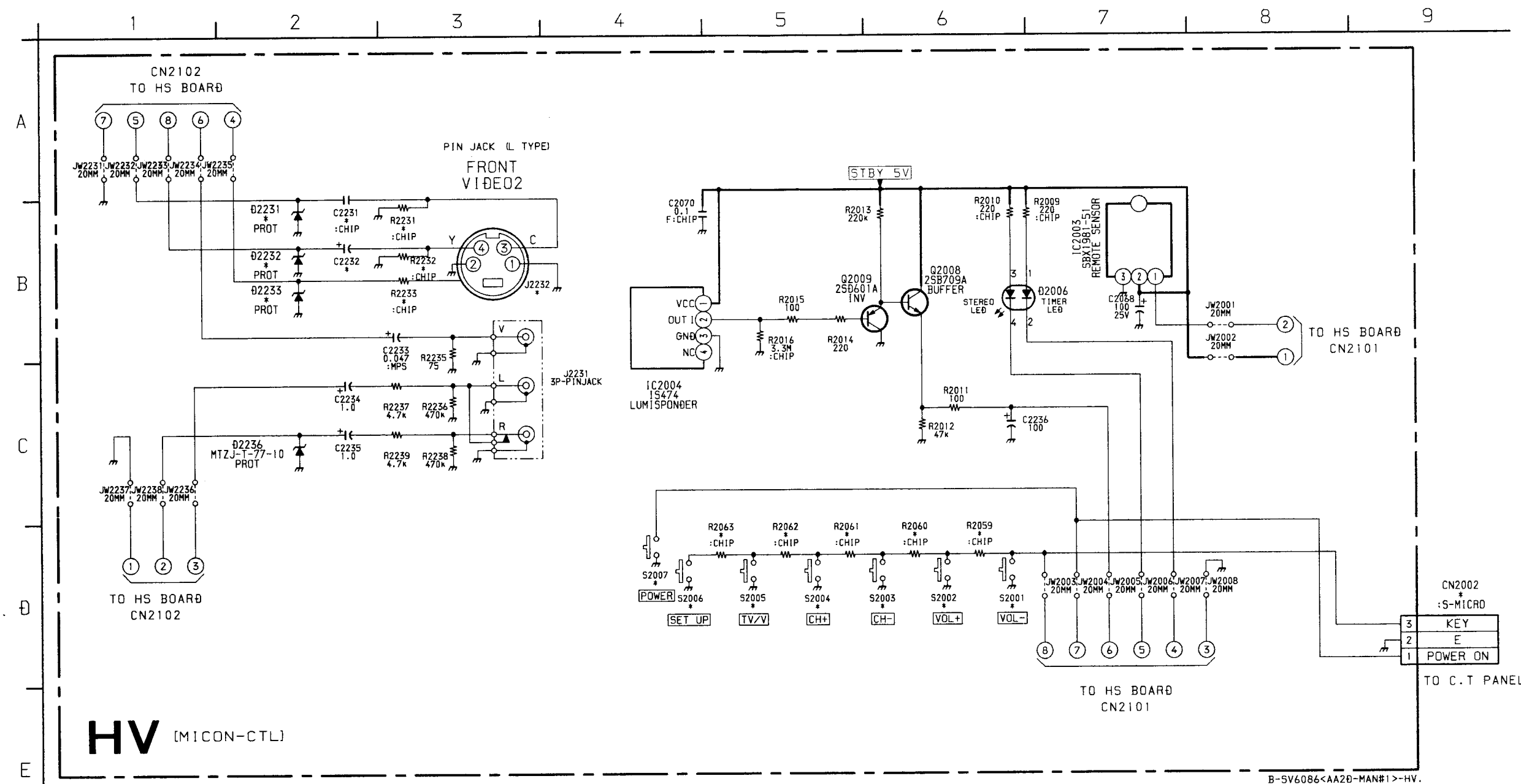

HV [FRONT VIDEO 2 IN, SIRCS SWITCH]

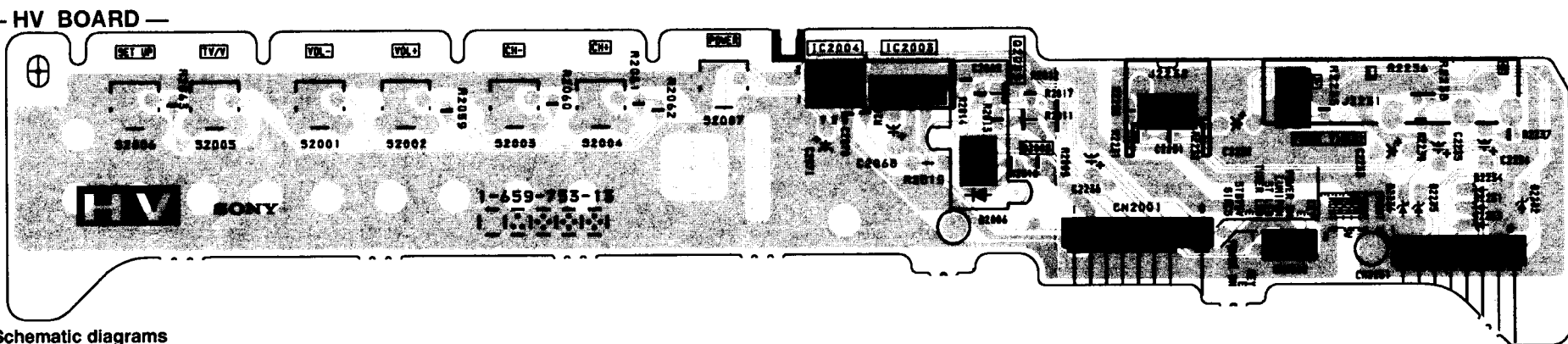

HV BOARD TRANSISTOR VOLTAGE LIST

	B	C	E
Q2008	4.5	5.0	1.5
Q2009	0.4	GND	4.5

All voltages are in V

HV BOARD IC VOLTAGE LIST

IC	pin	volt
IC2003	1	5.0
	2	5.0
	3	GND
IC2004	1	5.0
	2	0.5
	3	GND
	4	NC

All voltages are in V

HV BOARD * MARK LIST

	KV-32V26	KV-32V36/34V36C 35V36/35V76 37V36M
C2231	#	0.01
C2232	#	0.047
CN2002	#	3P
D2231	#	MTZJ-T-77-10
D2232	#	MTZJ-T-77-10
D2233	#	MTZJ-T-77-10
J2232	#	S-JACK
R2059	820	#
R2060	1K	#
R2061	1.8K	#
R2062	4.7	#
R2063	10	#
R2231	#	75
R2232	#	75
R2233	#	4.7K
S2001	TACTILE-SW	#
S2002	TACTILE-SW	#
S2003	TACTILE-SW	#
S2004	TACTILE-SW	#
S2005	TACTILE-SW	#
S2006	TACTILE-SW	#
S2007	TACTILE-SW	#

#: NOT MOUNTED

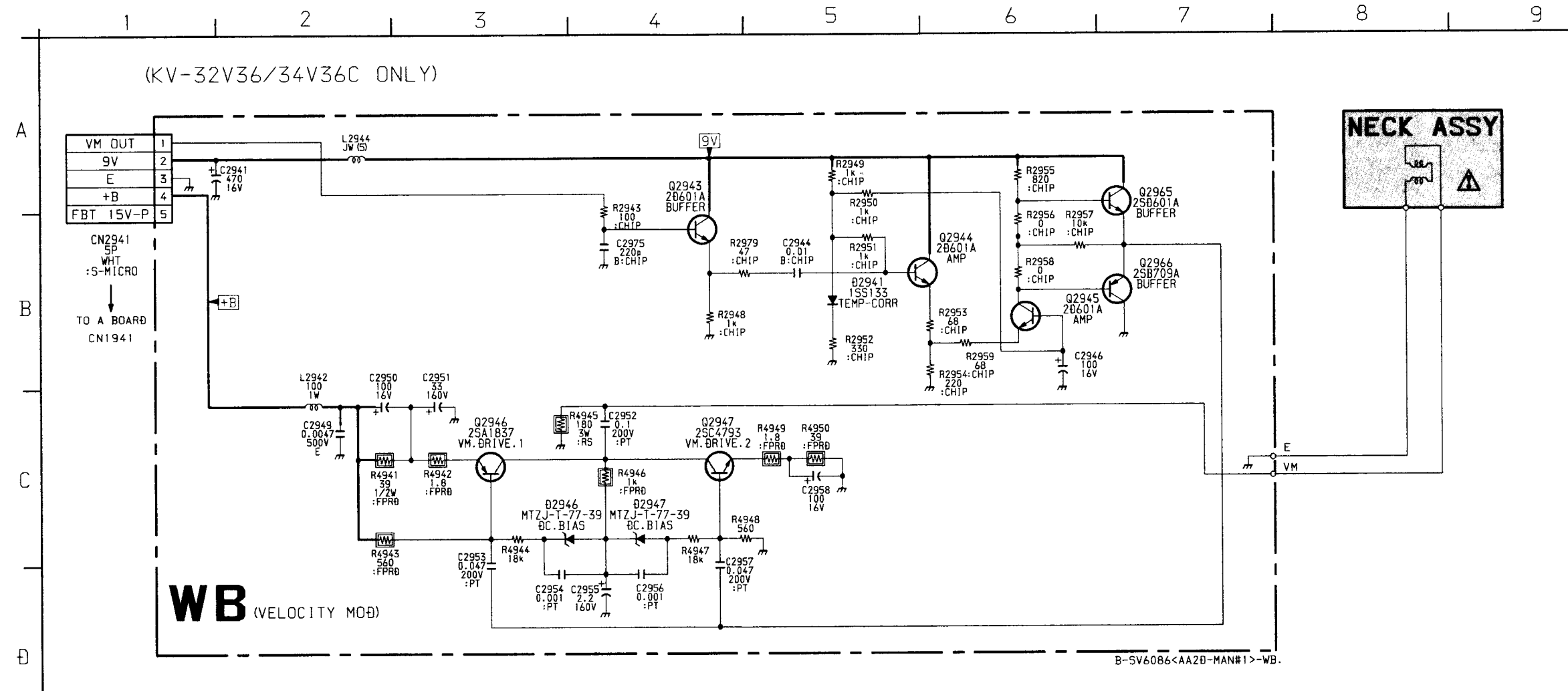

WB [VELOCITY MOD.]
(KV-32V36/34V36C ONLY)

— WB BOARD —

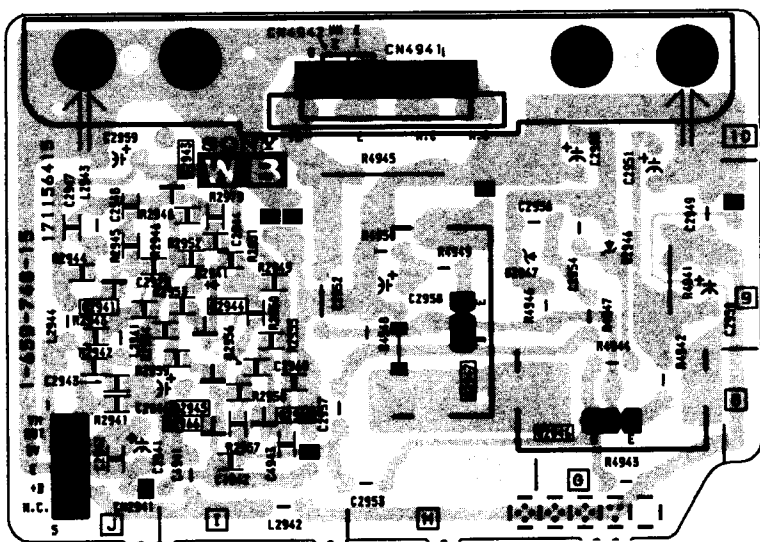

WB BOARD TRANSISTOR VOLTAGE LIST

	B	C	E
Q2943	3.1	9.0	2.4
Q2944	2.7	9.0	2.1
Q2945	2.8	5.8	2.1
Q2946	134.0	67.4	135.0
Q2947	1.8	67.4	0.5
Q2965	5.8	9.0	5.9
Q2966	5.8	GND	5.9

All voltages are in V

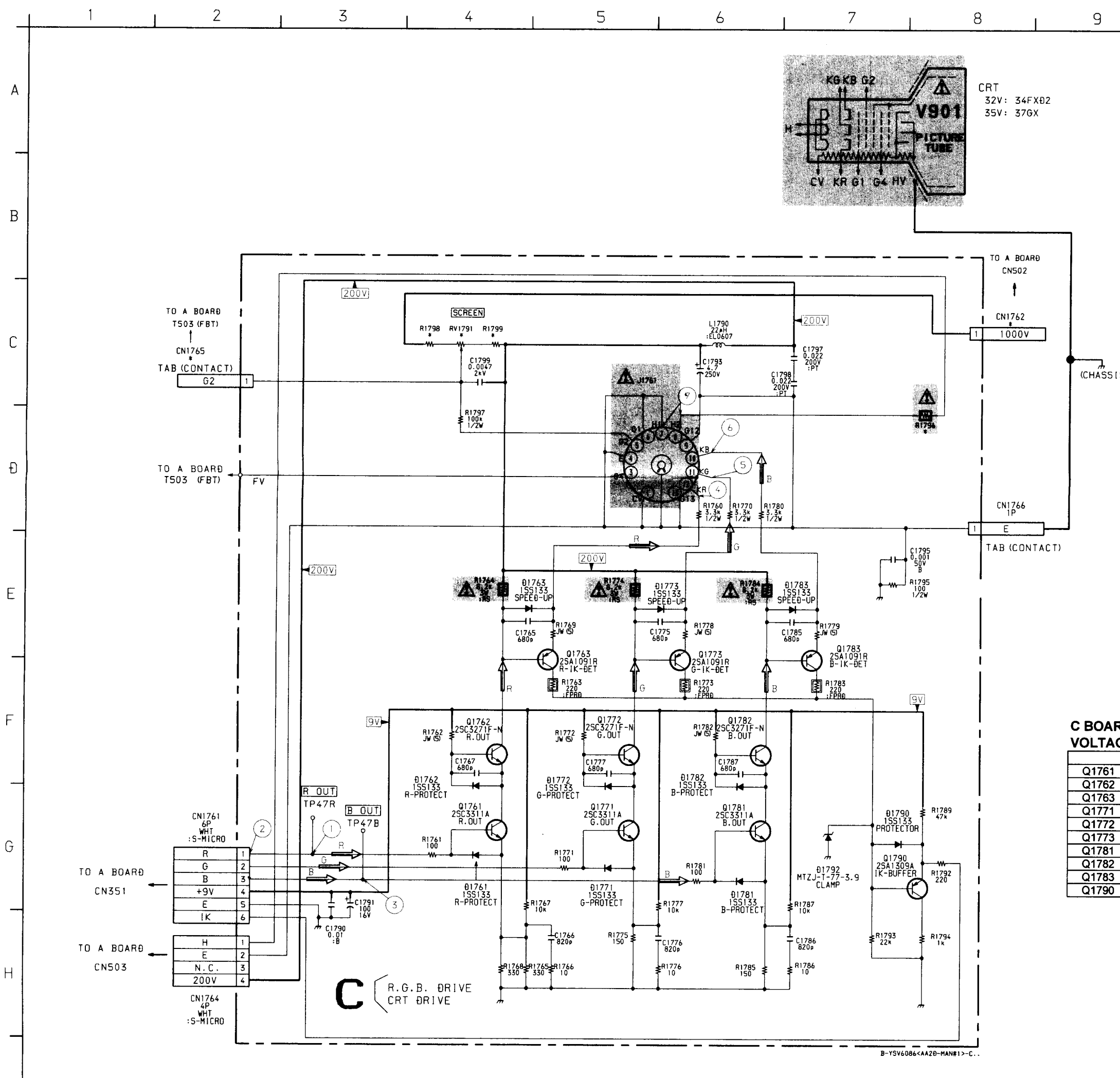

C BOARD TRANSISTOR VOLTAGE LIST

	B	C	E
Q1761	2.2	8.2	1.7
Q1762	8.7	134.1	8.2
Q1763	134.1	2.3	132.0
Q1771	1.8	8.2	1.3
Q1772	8.7	146.4	8.2
Q1773	146.4	2.3	144.1
Q1781	2.1	8.2	1.6
Q1782	8.7	133.7	8.2
Q1783	133.7	2.3	131.5
Q1790	2.2	0.2	2.5

All voltages are in V

C [R.G.B. OUT]
— C BOARD —

C BOARD * MARK LIST

	KV-32V26/32V36/32V36C	KV-35V36/35V76/37V36M
CN1762	#	1P
CN1765	#	TAB
R1796	2.7 / 2W	0.47 / 2W
R1798	#	680K / .5W
R1799	#	100K / .5W
RV1791	#	2.2M / .5W

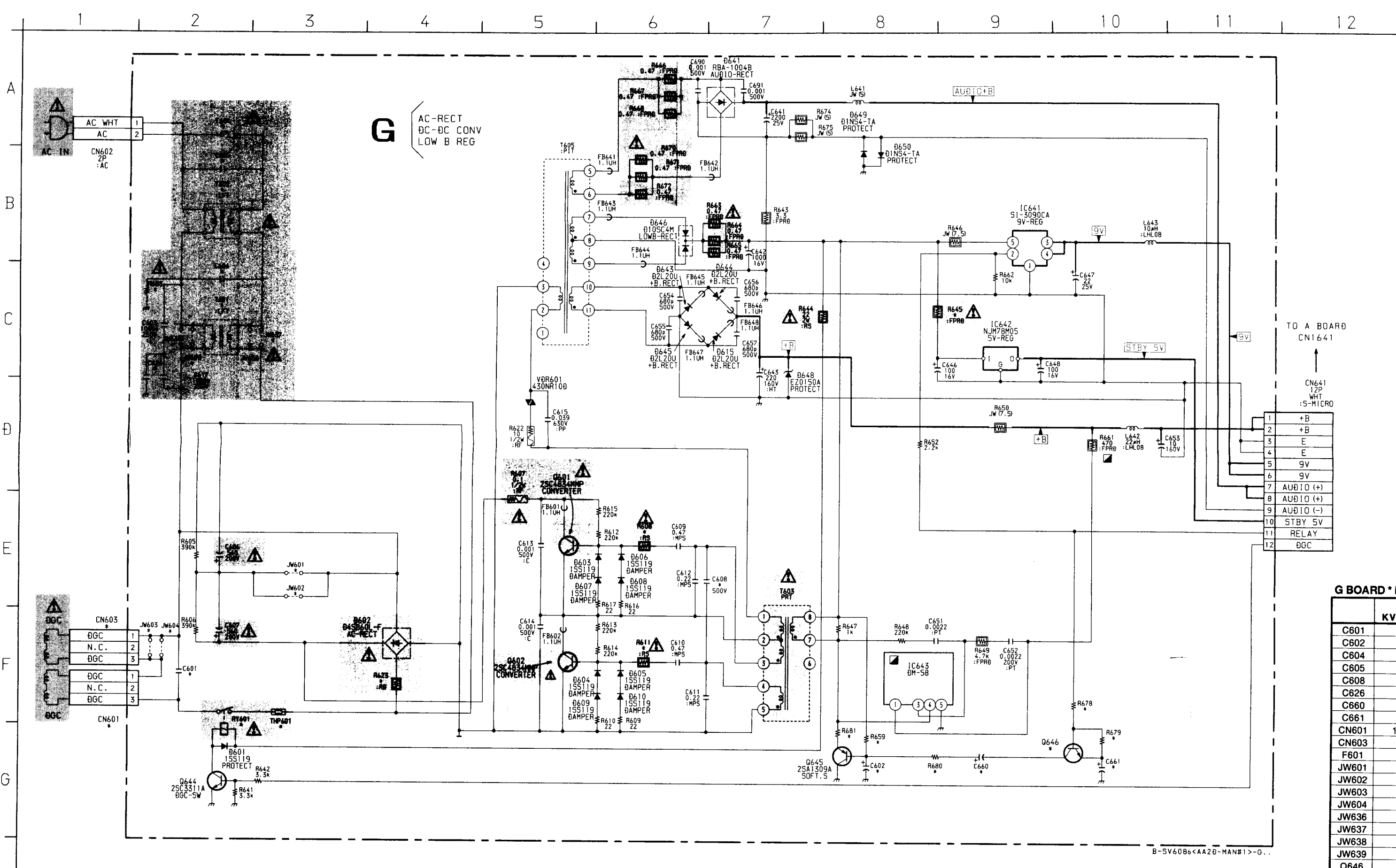
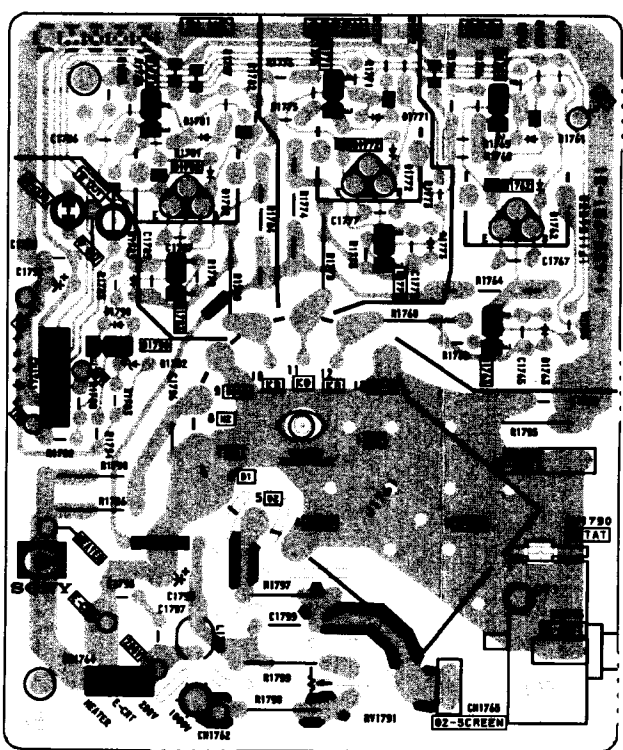
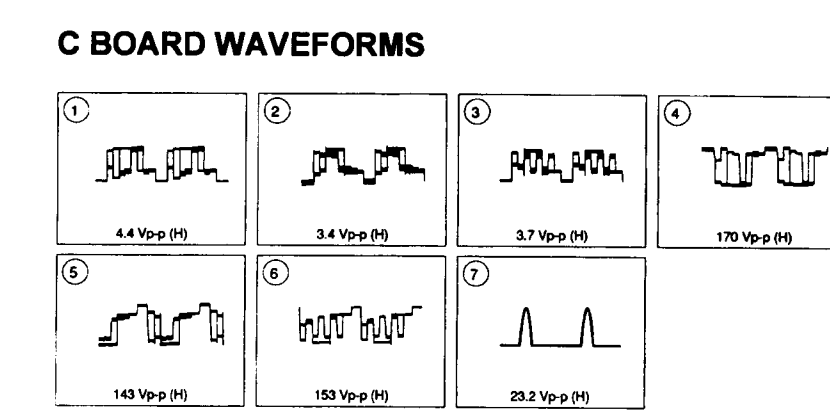

G BOARD * MARK LIST

	KV-32V26/32V36	KV-35V36/35V76/37V36M	KV-34V36C
C601	#	.22/250V	#
C602	#	#	4.7
C604	.22/125V	.22/125V	#
C605	.22/125V	.22/125V	.22/250V
C608	680p/500V	680p/500V	.001/500V
C626	JW(7.5)	JW(7.5)	100p/250V
C680	JW(5)	JW(5)	100p/250V
C681	4.7	4.7	#
CN601	1-508-765-21	1-573-963-11	1-508-765-21
CN603	#	1-573-963-11	#
F601	6.3A/125V	6.3A/125V	6.3A/250V
JW601	5MM	5MM	#
JW602	5MM	5MM	#
JW603	5MM	5MM	5MM
JW604	5MM	#	5MM
JW636	#	#	10MM
JW637	#	#	10MM
JW638	#	#	10MM
JW639	#	#	10MM
R646	25C3311A	25C3311A	#
R603	2.2M / 1/2W	2.2M / 1/2W	8.2M / 1W
R608	1.8 / 2W	1.8 / 2W	1.2W
R611	1.8 / 2W	1.8 / 2W	1.2W
R623	1 / 20W	1 / 20W	3.9 / 20W
R645	JW(5)	JW(5)	10 / 1/2W
R646	JW(7.5)	JW(7.5)	JW(7.5)
R659	#	#	10K
R676	22k	22k	#
R679	22k	22k	#
R680	10k	10k	#
R681	150	150	JW(5)
RY601	1-755-146-11	1-755-146-11	1-755-018-11
T601	1-426-717-11	1-426-717-11	#
T602	1-424-220-11	1-424-220-11	1-426-717-11
THP601	1-809-539-11	1-809-539-11	1-809-827-11

NOT MOUNTED

G BOARD TRANSISTOR VOLTAGE LIST

	B	C	E
Q601	145.2	294.0	147.5
Q602	-1.7	147.5	GND
Q644	0	10.5	GND

All voltages are in V

G BOARD IC VOLTAGE LIST

IC	pin	volt
IC641	1	GND
	2	3.9
	3	8.9
	4	8.9
	5	10.5
IC642	IN	9.5
	OUT	5.0
IC643	1	135
	2	NC
	3	2.5
	4	7.8
	5	GND

All voltages are in V

G [POWER SUPPLY]
— G BOARD —

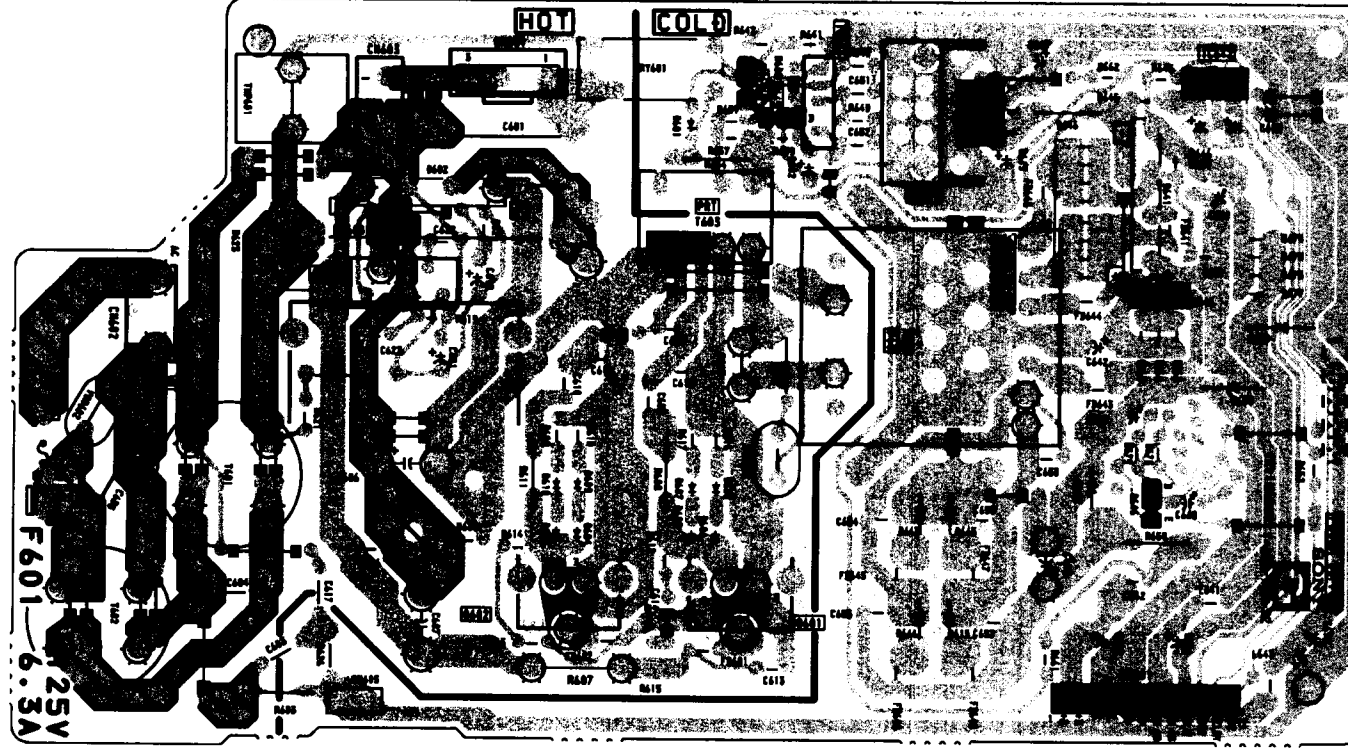

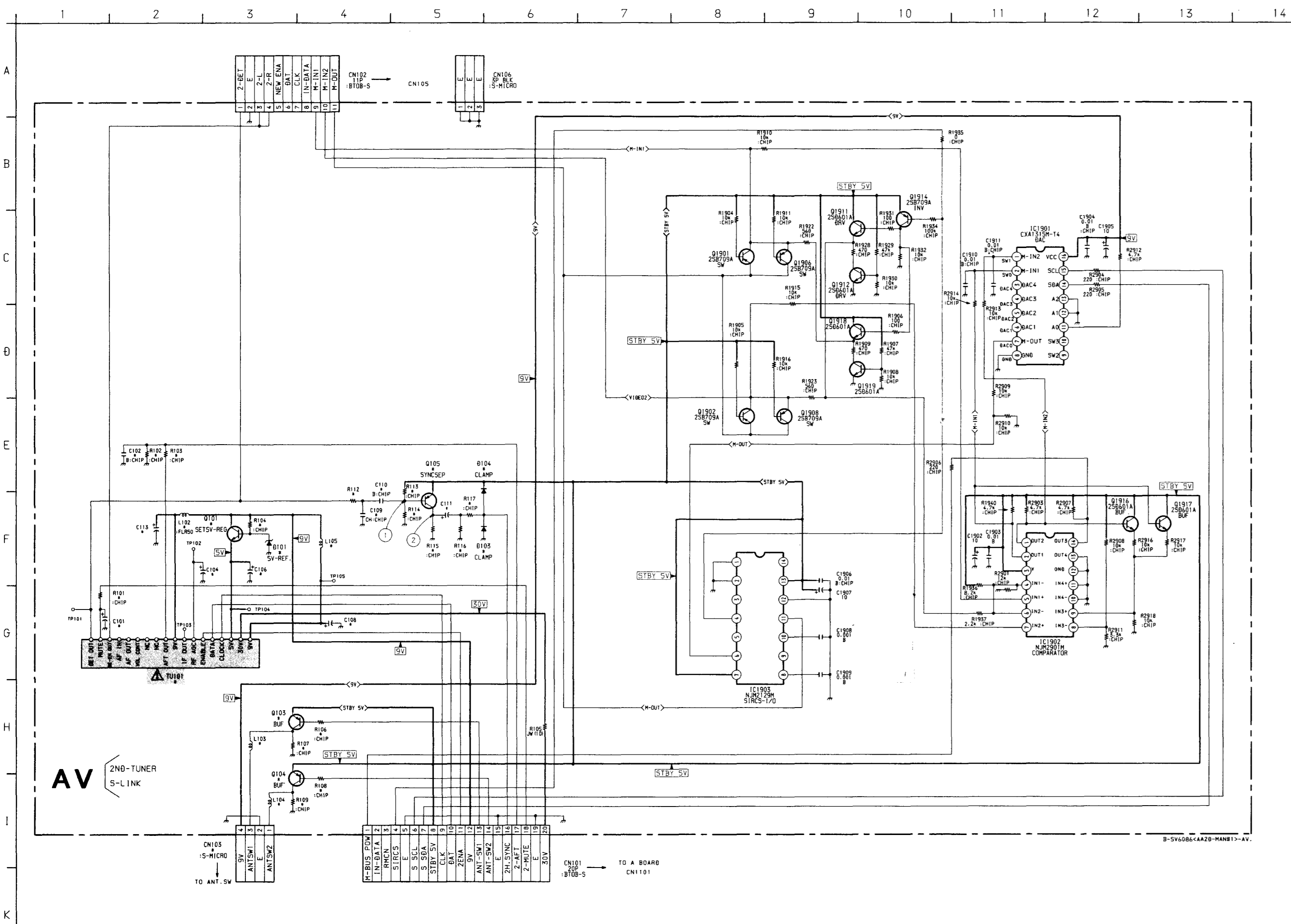

AV (2ND-TUNER S-LINK)

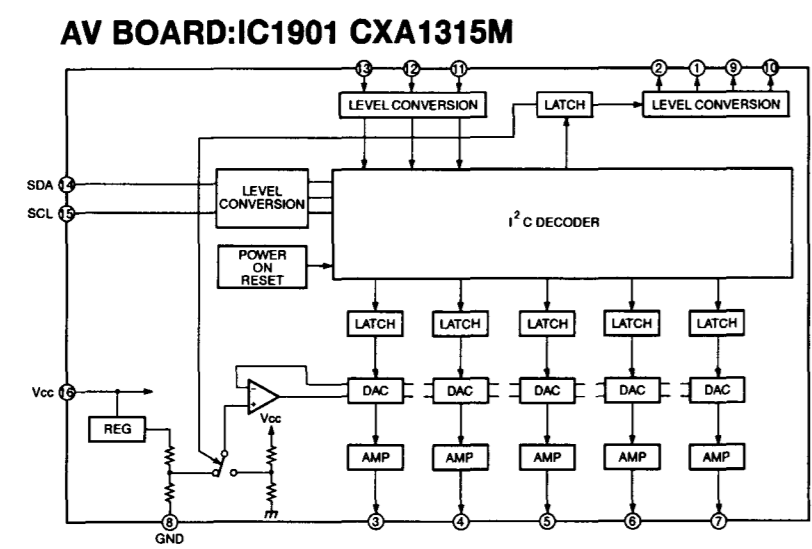
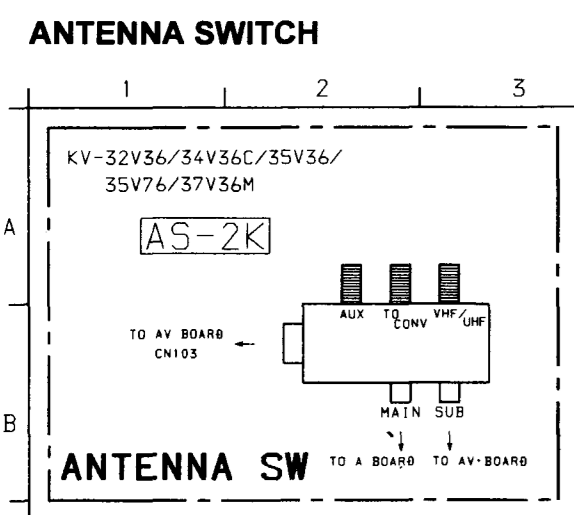

AV BOARD: IC1901 CXA1315M

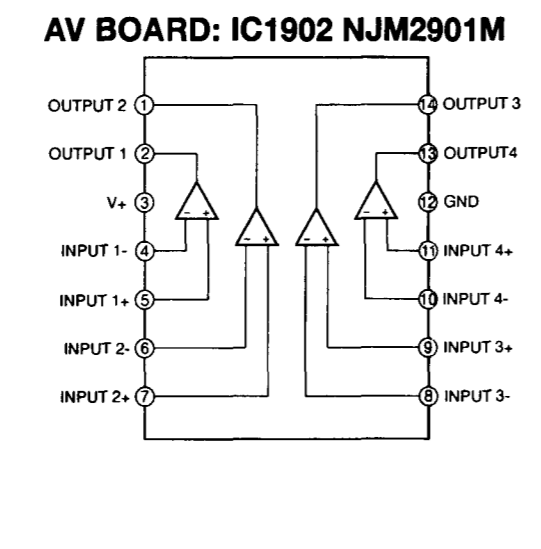

AV BOARD: IC1902 NJM2901M

AV BOARD WAVEFORMS

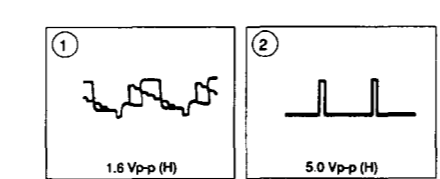

AV BOARD TRANSISTOR VOLTAGE LIST

Q	B	C	E
Q101	5.8	8.7	5.1
Q103	4.3	4.9	5.0
Q104	5.0	0	5.0
Q105	5.0	0.8	5.0
Q1901	5.0	0	0
Q1902	5.0	0	0
Q1906	5.0	0	0
Q1908	5.0	0	0
Q1911	0	5.0	0
Q1912	0.7	0	GND
Q1914	4.9	0	5.0
Q1916	0.2	5.0	0
Q1917	0.2	5.0	0

All voltages are in V

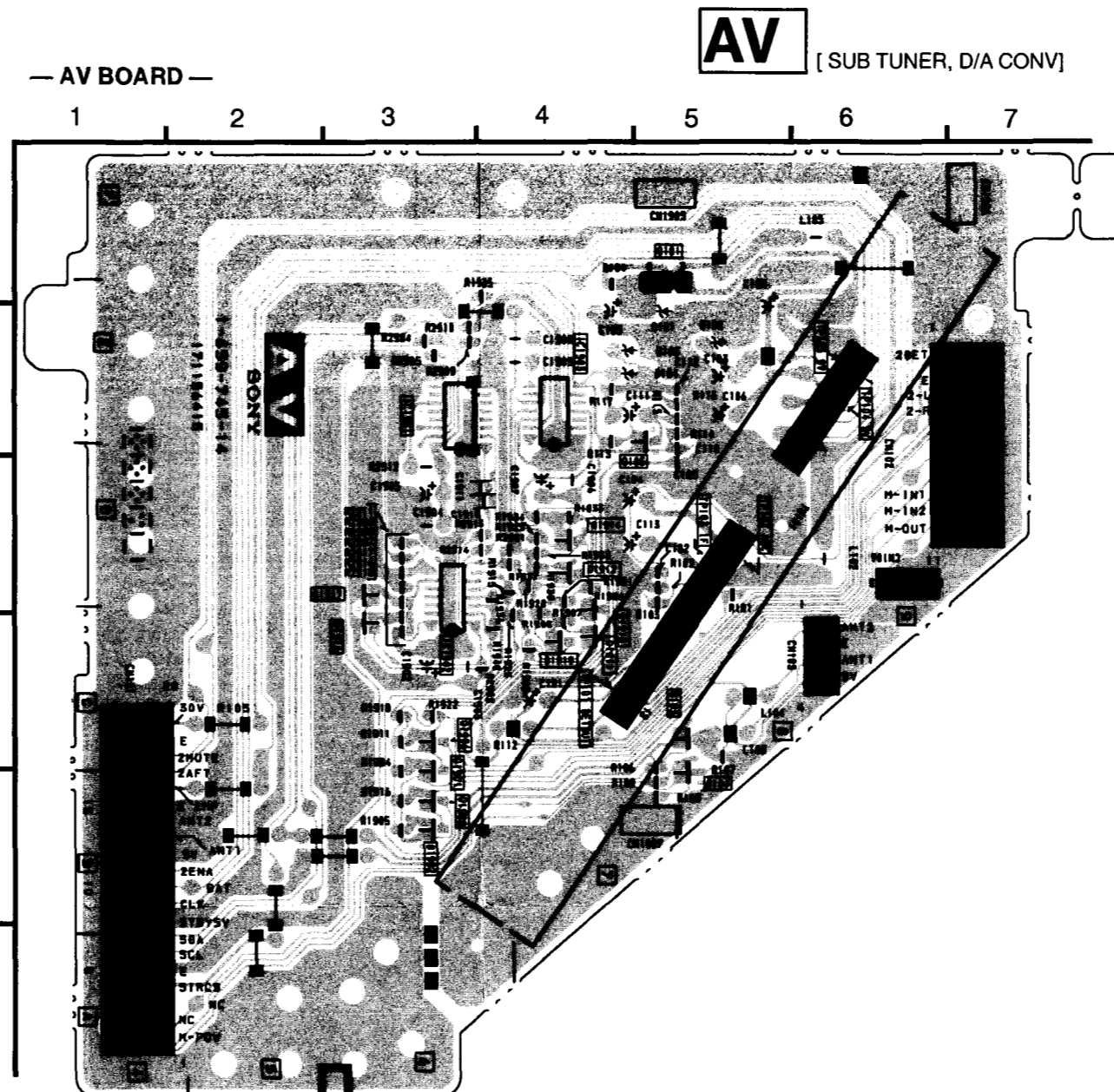

AV BOARD * MARK LIST

Part	Value	Part	Value
C101	#	1	
C102	#	0.0022	
C104	#	10	
C106	#	47/25V	
C108	#	100/16V	
C109	#	220P	
C110	#	0.047	
C111	#		
C113	#	220/16V	
CN103	#	4P	
D101	#	MTZJ-T-77-5.6C	
D104	#	1SS133	
L102	#	100uH	
L103	#	JW(S)	
L104	#	JW(S)	
L105	#	100uH	
Q101	#	2SC3311A	
Q103	#	2SB709A	
Q104	#	2SB709A	
Q105	#	2SB709A	
R101	#	4.7k	
R102	#	27k	
R103	#	39k	
R104	#	680	
R106	#	22k	
R107	#	22k	
R108	#	22k	
R109	#	22k	
R112	#	2.2k	
R113	#	100k	
R114	#	1M	
R115	#	10k	
R116	#	10k	
R117	#	4.7k	
TU101	#	BTF-LA402	

AV BOARD IC VOLTAGE LIST

IC	pin	volt	pin	volt
IC1901	1	0.2	7	0
	2	0.2	8	1.3
	3	NC	9	0
	4	NC	10	GND
	5	NC	11	GND
	6	NC	12	GND
	7	NC	13	GND
IC1903	9	NC	1	GND
	10	NC	2	GND
	11	8.7	3	NC
	12	GND	4	5.0
	13	GND	5	NC
	14	4.9	6	0.2
	15	5.0	7	5.0
	16	8.7	8	0.4
	17	0	9	NC
	18	0	10	0
IC1902	1	0.2	9	NC
	2	0.2	10	0.4
	3	5.0	11	0
	4	1.3	12	0
IC1917	5	0	13	5.0
	6	1.3	14	NC

All voltages are in V

AV [SUB TUNER, D/A CONV]

AV BOARD DIODE

D101	B-5
D103	B-4
D104	B-4

IC

IC1901	B-3
IC1902	C-3
IC1903	B-4

TRANSISTOR

Q101	A-5
Q103	D-5
Q104	D-5
Q105	B-4
Q1901	D-3
Q1902	E-3
Q1906	D-3
Q1908	E-3
Q1911	C-4
Q1912	C-4
Q1914	C-4
Q1916	C-3
Q1917	C-3

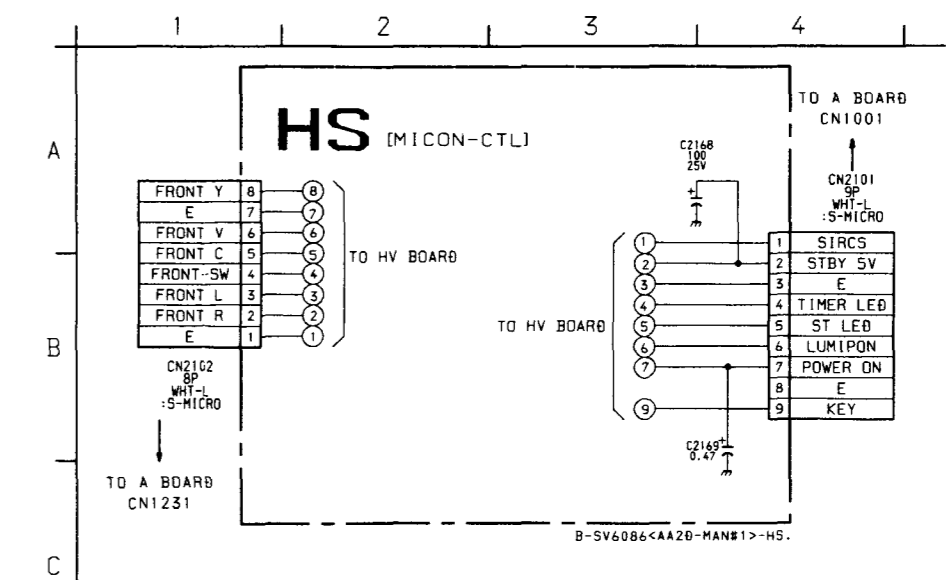

HS [SW] (EXCEPT KV-37V36M)

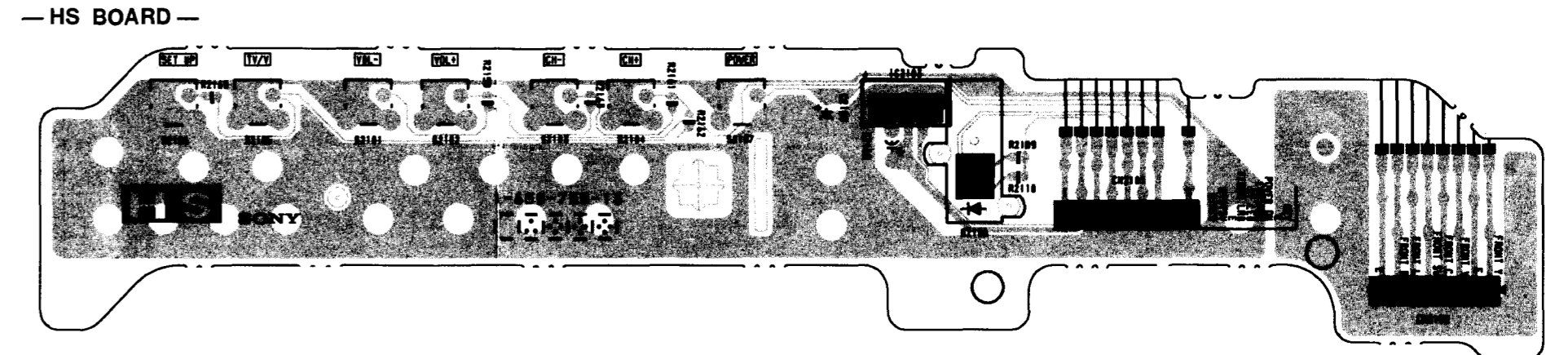

K [AUDIO AMP] (KV-32V36/34V36C/35V76 ONLY)

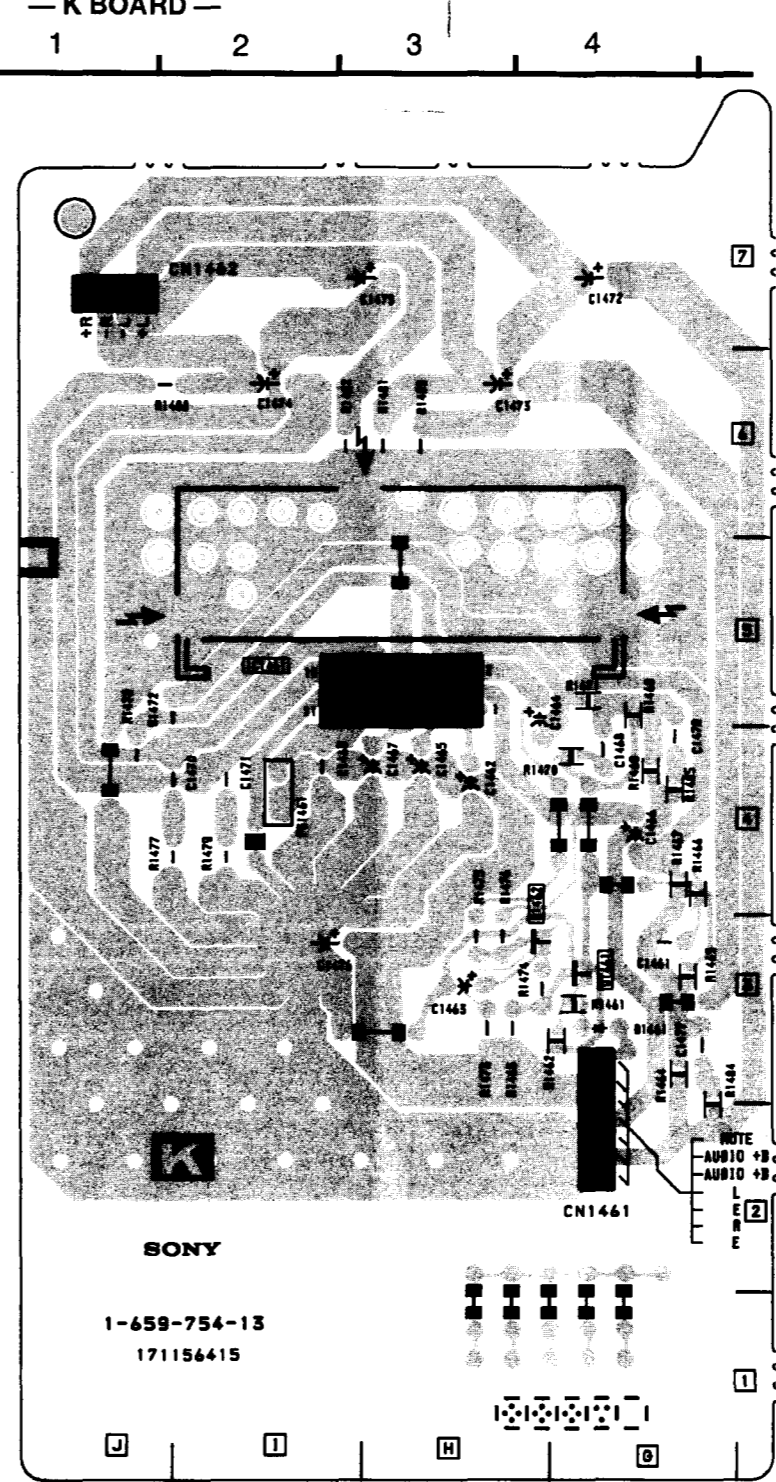

K BOARD IC VOLTAGE LIST

IC1461	pin	volt
	1	1.5
	2	4.2
	3	12.2
	4	4.5
	5	1.5
	6	GND
	7	NC
	8	0.2
	9	22.1
	10	0.2
	11	NC

All voltages are in V

K BOARD TRANSISTOR VOLTAGE LIST

Q	B	C	E
Q1461	0.7	0	GND
Q1462	20.0	20.7	20.7

All voltages are in V

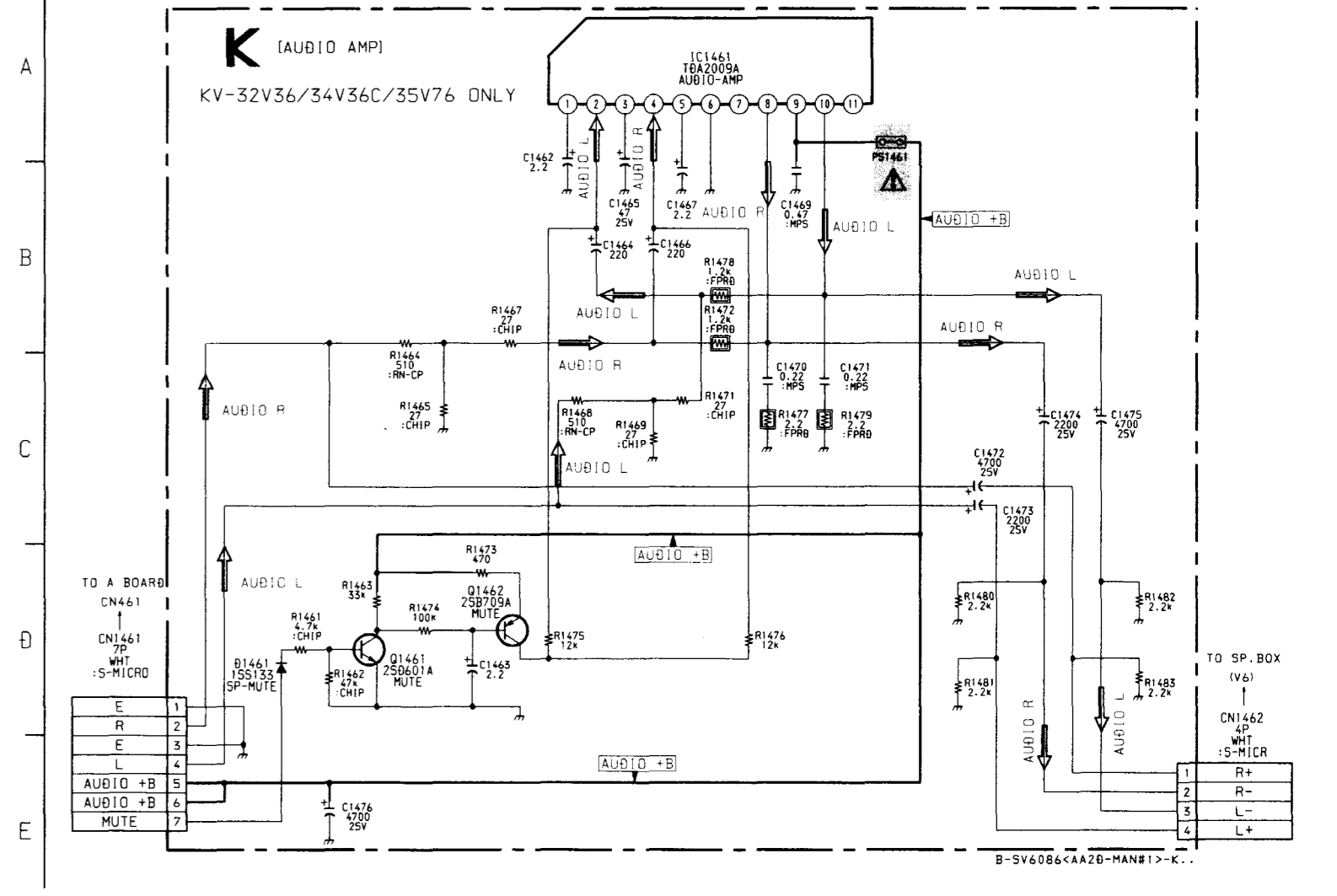
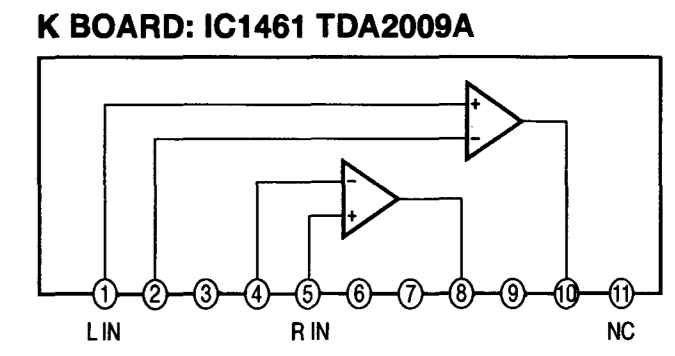

4-5. SEMICONDUCTORS

BH3856FS-E2

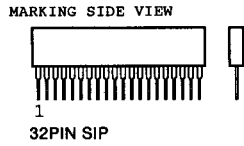

CD4052BCN

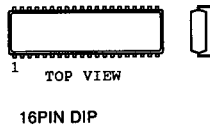

CXA1315M

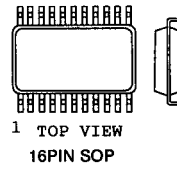

CXA-2019Q-T4

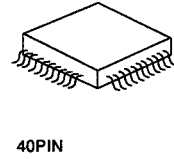

CXA2025AS

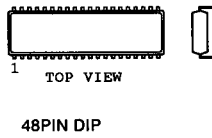

CXP85640-002S

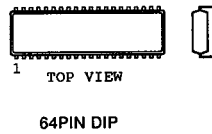

DM-58

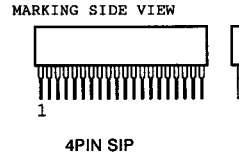

IS474

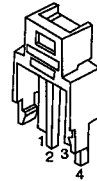

LM2901M

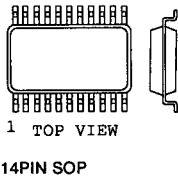

M5216P

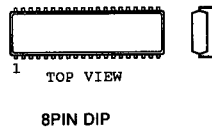

MM1313AD

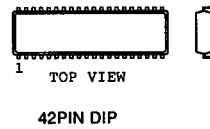

NJM2129M-TE2

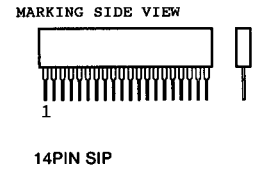

NJM2902M

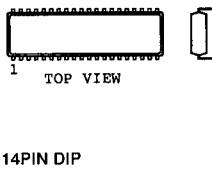

NJM2903M
NJM2904M
ST24CO2FM6TR
UPC4558G2

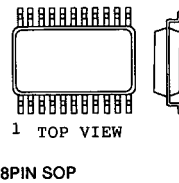

NJM78M05FA
TA7805S



SBX1790-51

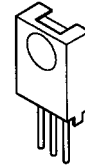

SDA9288X

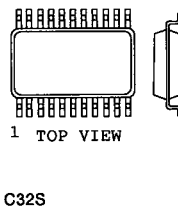

IRF614

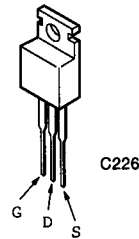

STV9379

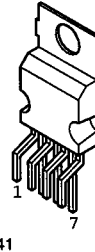

TDA2009A

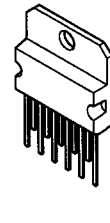

FMGAT148
2SC5418

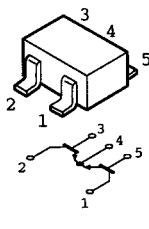

2SA1037AK-T146-R
2SA1162-G
2SA1130-06
2SD601A-Q

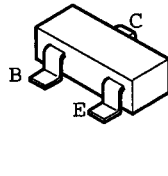

2SA1091-0

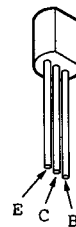

2SA1175-HFE
2SC2785-HFE

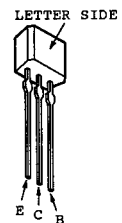

2SA1837
2SC4159-E

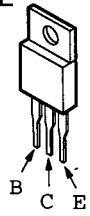

T046

2SC2611

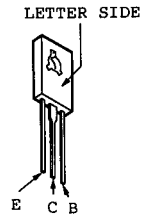

2SC4834M

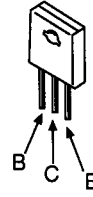

2SC3209LK

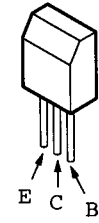

T075

D10SC4M



D216

D1NS4
MTZJ-3.3
MTZJ-33A
MTZJ-6.2B
MTZJ-7.5B
RD10ESB2
RD39ES-B2
RD5.6ESB2
1SS19-25

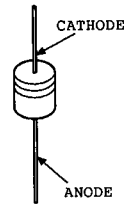

D026

D2L2OU
EL1Z
EZ0150AV1
GP08D
MTZJ-T-77-3.9
RGP02-17EL-6433

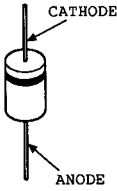

D032

D4SB60L
RBA-1004B

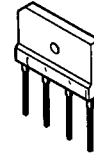

D029

ERC06-15S
ISSI33T-77

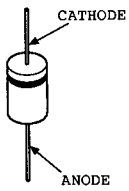

D030

ERD29-08J

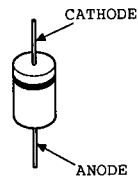

D095

SECTION 5 EXPLODED VIEWS

- Items with no part number and no description are not stocked because they are seldom required for routine service.
- The construction parts of an assembled part are indicated with a collation number in the remark column.

- Items marked "*" are not stocked since they are seldom required for routine service. Some delay should be anticipated when ordering these items.

Note:

The components identified by shading and mark Δ are critical for safety. Replace only with part number specified.

Note:

Les composants identifiés par un trame et une marque Δ sont critiques pour la sécurité. Ne les remplacer que par une pièce portant le numéro spécifié.

5-1. CHASSIS (32V26/32V36/34V36C ONLY)

- 7-685-663-71 SCREW +BVTP 4X16

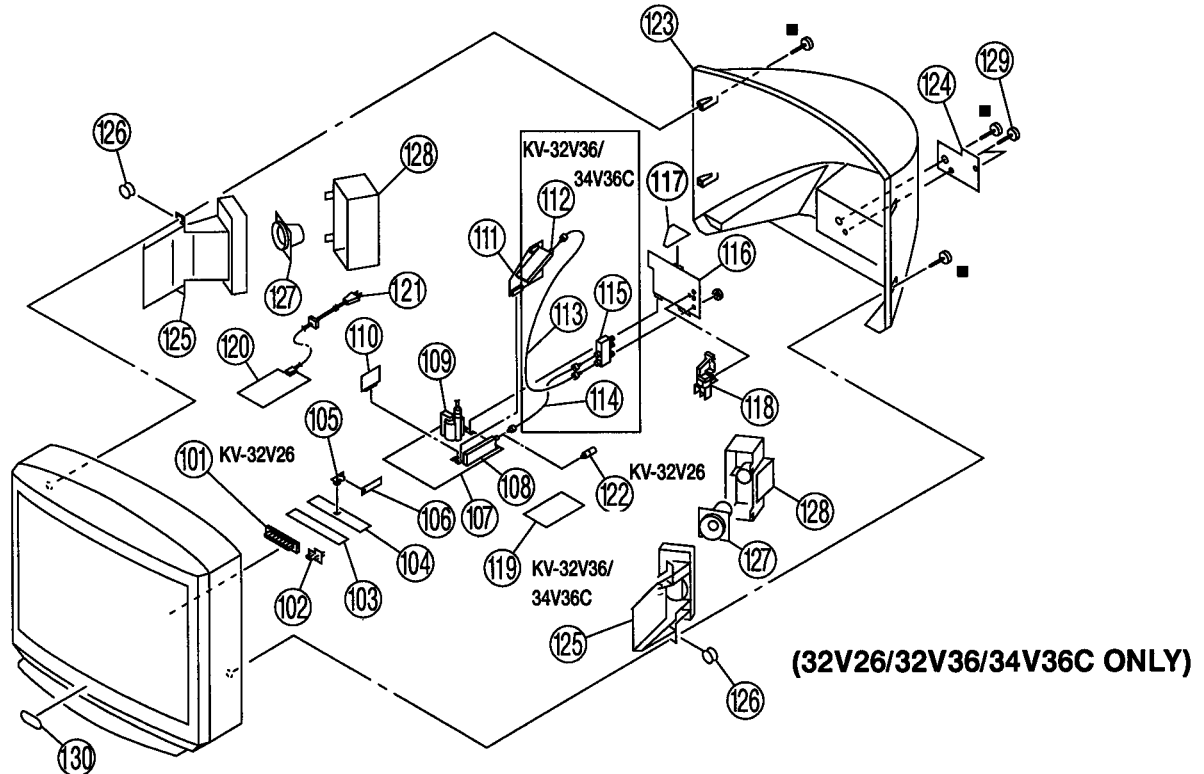

REF.NO.	PART NO.	DESCRIPTION	REMARK
101	4-052-907-01	BUTTON, MULTI (KV-32V26)	
102	* 4-052-897-01	GUIDE, LED	
103	* A-1372-325-A	HV BOARD, COMPLETE (KV-32V26)	
103	* A-1372-330-A	HV BOARD, COMPLETE (KV-32V36/34V36C)	
104	* A-1372-326-A	HS BOARD	
105	* 3-696-606-02	HINGE, VI	
106	* 1-659-757-11	SA BOARD	
107	* A-1298-062-A	A BOARD, COMPLETE (KV-32V26)	
107	* A-1298-082-A	A BOARD, COMPLETE (KV-32V36/34V36C)	
108	Δ 8-598-340-00	TUNER BTF-WA404	
109	Δ 1-453-207-11	TRANSFORMER ASSY, FLYBACK (NX-2609)	
110	* A-1195-115-A	P BOARD, COMPLETE	
111	* A-1297-720-A	AV BOARD, COMPLETE (KV-32V36/34V36C)	
111	* A-1297-850-A	AV BOARD, COMPLETE (KV-32V26)	
112	Δ 8-598-339-00	TUNER BTF-LA402 (KV-32V36/34V36C)	
113	* 1-557-056-31	CABLE, P-P (KV-32V36/34V36C)	
114	* 1-556-945-21	CABLE, P-P (KV-32V36/34V36C)	
115	8-598-414-00	SWITCH, ANTENNA AS-2F (KV-32V36/34V36C)	
116	* A-1394-846-A	UV BOARD, COMPLETE (KV-32V36/34V36C)	
116	* A-1394-844-A	UV BOARD, COMPLETE (KV-32V26)	

REF.NO.	PART NO.	DESCRIPTION	REMARK
117	* A-1390-585-A	SC BOARD, COMPLETE	
118	* 4-052-905-01	BRACKET, V5/6 (KV-32V36/34V36C)	
119	* A-1380-518-A	K BOARD, COMPLETE (KV-32V36/34V36C)	
120	* A-1316-252-A	G BOARD, COMPLETE (KV-34V36C)	
120	* A-1316-261-A	G BOARD, COMPLETE (KV-32V26/34V36C)	
121	Δ 1-751-059-11	CORD POWER (WITH CONNECTOR) (KV-32V26/32V36)	
121	Δ 1-769-796-41	CORD POWER (WITH CONNECTOR) (KV-34V36C)	
122	1-766-374-11	PLUG, F-PIN (KV-32V26)	
123	4-053-766-11	COVER, REAR	
124	4-052-898-11	LABEL, TERMINAL (KV-32V36/34V36C)	
124	4-052-899-11	LABEL, TERMINAL (KV-32V26)	
125	4-043-457-11	BAFFLE, SPEAKER	
126	4-374-745-31	CUSHION (A)	
127	1-504-524-11	SPEAKER (8CM) (KV-32V26)	
127	1-505-326-11	SPEAKER (8CM) (KV-32V36/34V36C)	
128	X-4032-226-1	COVER ASSY, SPEAKER (KV-32V26)	
128	X-4033-616-1	COVER ASSY, SPEAKER (KV-32V36/34V36C)	
129	4-041-165-01	SCREW (3X12) TAPPING, +BV	
130	4-046-160-01	EMBLEM (NO.9), SONY	

Note:

The components identified by shading and mark Δ are critical for safety. Replace only with part number specified.

Note:

Les composants identifiés par un triangle et une marque Δ sont critiques pour la sécurité. Ne les remplacer que par une pièce portant le numéro spécifié.

5-2. PICTURE TUBE (32V26/32V36/34V36C ONLY)

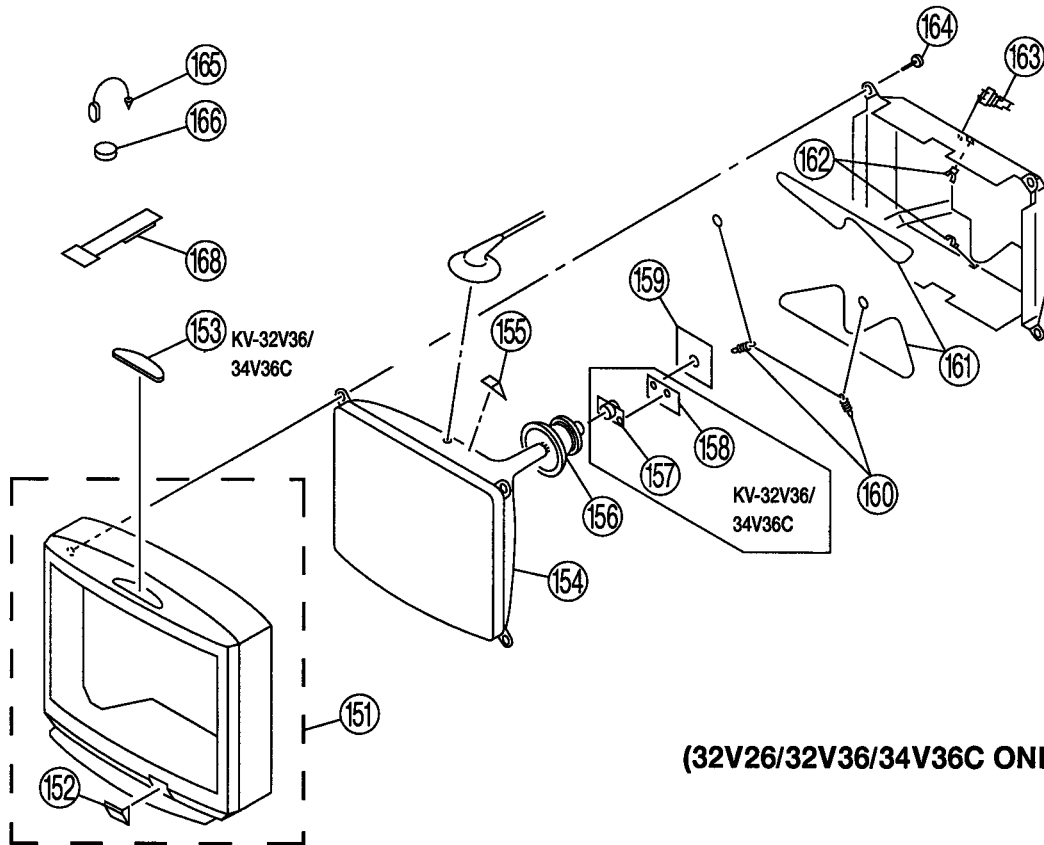

(32V26/32V36/34V36C ONLY)

REF.NO.	PART NO.	DESCRIPTION	REMARK
151	X-4034-596-1	BEZNET ASSY (KV-32V26)	152
151	X-4033-597-1	BEZNET ASSY (KV-32V36/34V36C)	152
152	4-052-906-21	DOOR, CONTROL (KV-32V26)	
152	4-052-906-51	DOOR, CONTROL (KV-32V36/34V36C)	
153	1-473-549-11	SWITCH BLOCK, CONTROL (KV-32V36/34V36C)	
154 Δ	8-733-745-05	CRT34FXD2 (M80JYV51X) (KV-32V26/32V36)	
154 Δ	8-733-746-05	CRT34FXD2 (M80JYV51X) (KV-34V36C)	
155	4-053-005-01	SPACER, DEFLECTION YOKE	
156	8-451-482-21	DEFLECTION YOKE (Y34FXA2-X)	
157 Δ	1-452-579-21	NECK ASSY, CRT (NA322) (KV-34V36C)	

REF.NO.	PART NO.	DESCRIPTION	REMARK
158 *	A-1372-225-A	WB BOARD, COMPLETE (KV-32V36/34V36C)	
159 *	A-1331-549-A	C BOARD, COMPLETE	
160	4-036-329-01	SPRING (B), TENSION	
161 Δ	1-402-952-11	COIL, DEMAGNETIC (KV-32V26/32V36)	
161 Δ	1-411-474-11	COIL, DEMAGNETIC (KV-34V36C)	
162	4-371-629-01	STOPPER WIRE	
163	4-033-681-01	HOLDER, LEAD	
164	4-041-268-01	SCREW (7), TAPPING	
165	4-308-870-00	CLIP LEAD WIRE	
166	1-452-032-00	MAGNET, DISC	
168	4-051-737-21	PIECE A (100), CONV. CORRECT	

5-3. CHASSIS (35V36/35V76/37V36M ONLY)

- 7-685-648-79 SCREW +BVTP 3X12
- 7-685-663-71 SCREW +BVTP 4X16

Note:

The components identified by shading and mark Δ are critical for safety. Replace only with part number specified.

Note:

Les composants identifiés par un trame et une marque Δ sont critiques pour la sécurité. Ne les remplacer que par une pièce portant le numéro spécifié.

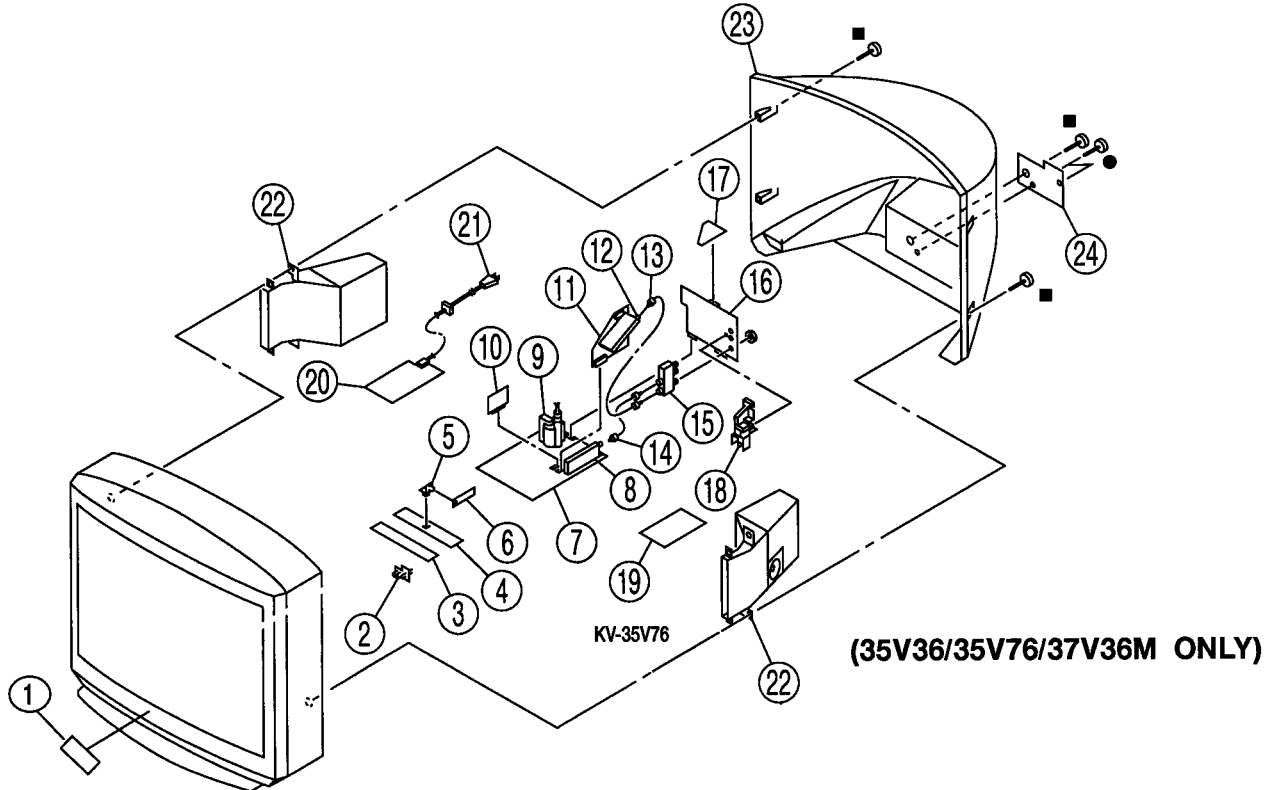

REF.NO.	PART NO.	DESCRIPTION	REMARK
1	4-046-160-01	EMBLEM (NO. 9) SONY	
2 *	4-052-897-01	GUIDE, LED	
3 *	A-1372-330-A	HV BOARD, COMPLETE	
4 *	A-1372-326-A	HS BOARD, COMPLETE	
5 *	3-696-606-02	HINGE, VI	
6	1-659-757-13	SA BOARD	
7 *	A-1298-087-A	A BOARD, COMPLETE (KV-35V36/37V36M)	
7 *	A-1298-088-A	A BOARD, COMPLETE (KV-35V76)	
8 Δ	8-598-340-00	TUNER BTF-WA404	
9 Δ	1-453-126-11	TRANSFORMER ASSY, FLYBACK (NX-300A3)	(KV-35V36/35V76)
9 Δ	1-439-50-11	TRANSFORMER ASSY, FLYBACK (NX-3001)	(KV-37V36M)
10 *	A-1195-115-A	P BOARD, COMPLETE	
11 *	A-1297-720-A	AV BOARD, COMPLETE	
12 Δ	8-598-339-00	TUNER BTF-LA402	

REF.NO.	PART NO.	DESCRIPTION	REMARK
13 *	1-557-056-31	CABLE, P-P	
14 *	1-556-945-21	CABLE, P-P	
15	8-598-414-00	ANTENNA SWITCH AS-2F	
16 *	A-1394-846-A	UV BOARD, COMPLETE (KV-35V76)	
16 *	A-1394-847-A	UV BOARD, COMPLETE (KV-35V36/37V36M)	
17 *	A-1390-585-A	SC BOARD, COMPLETE	
18 *	4-052-905-01	BRACKET, V5/6	
19 *	A-1380-518-A	K BOARD, COMPLETE (KV-35V76)	
20 *	A-1316-262-A	G BOARD, COMPLETE	
21	1-751-059-11	CORD, POWER (WITH CONNECTOR) 10A/125V	
22	1-505-684-11	SPEAKER UNIT, BOX TYPE-2 WAY	
23	4-052-903-01	COVER, REAR	
24	4-052-898-11	LABEL, TERMINAL (KV-35V76)	
24	4-052-899-11	LABEL, TERMINAL (KV-35V36/37V36M)	

5-4. PICTURE TUBE (35V36/35V76/37V36M ONLY)

- : 7-685-648-79 +BVTP 3X12
- : 7-685-663-79 +BVTP 4X16

Note:

The components identified by shading and mark Δ are critical for safety. Replace only with part number specified.

Note:

Les composants identifiés par un trame et une marque Δ sont critiques pour la sécurité. Ne les remplacer que par une pièce portant le numéro spécifié.

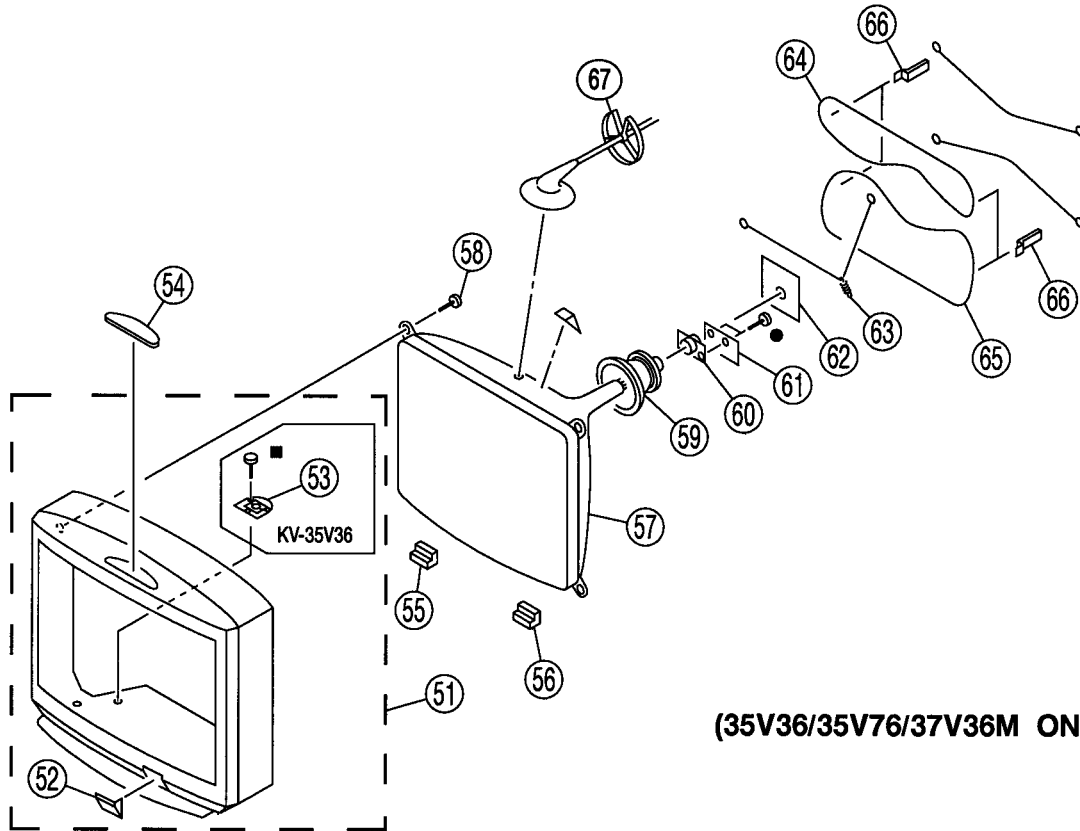

(35V36/35V76/37V36M ONLY)

REF.NO.	PART NO.	DESCRIPTION	REMARK
51	X-4034-522-1	BEZNET ASSY (KV-35V36/37V36M)	52
51	X-4034-523-2	BEZNET ASSY (KV-35V76)	52, 53
52	4-052-906-51	DOOR, CONTROL	
53	X-4032-889-1	CLAMP ASSY (KV-35V76)	
54	1-473-549-11	SWITCH BLOCK, CONTROL	
55	4-052-902-01	CRT SUPPORT (L)	
56	4-052-901-01	CRT SUPPORT (R)	
57	Δ 8-733-760-71	ITC 37GX-A1	
58	4-046-765-01	SCREW, TAPPING	
60	8-453-007-11	NA324-M	
61	* A-1372-211-A	WA BOARD, COMPLETE	
62	* A-1331-522-A	C BOARD, COMPLETE	
63	4-036-329-01	SPRING (B), TENSION	
64	1-411-881-11	COIL, DEMAGNETIC	
66	* 4-052-900-01	HOLDER, DGC	
67	3-704-372-31	HOLDER, HV CABLE	

5-5. CABINET BASE (KV-35V76 ONLY)

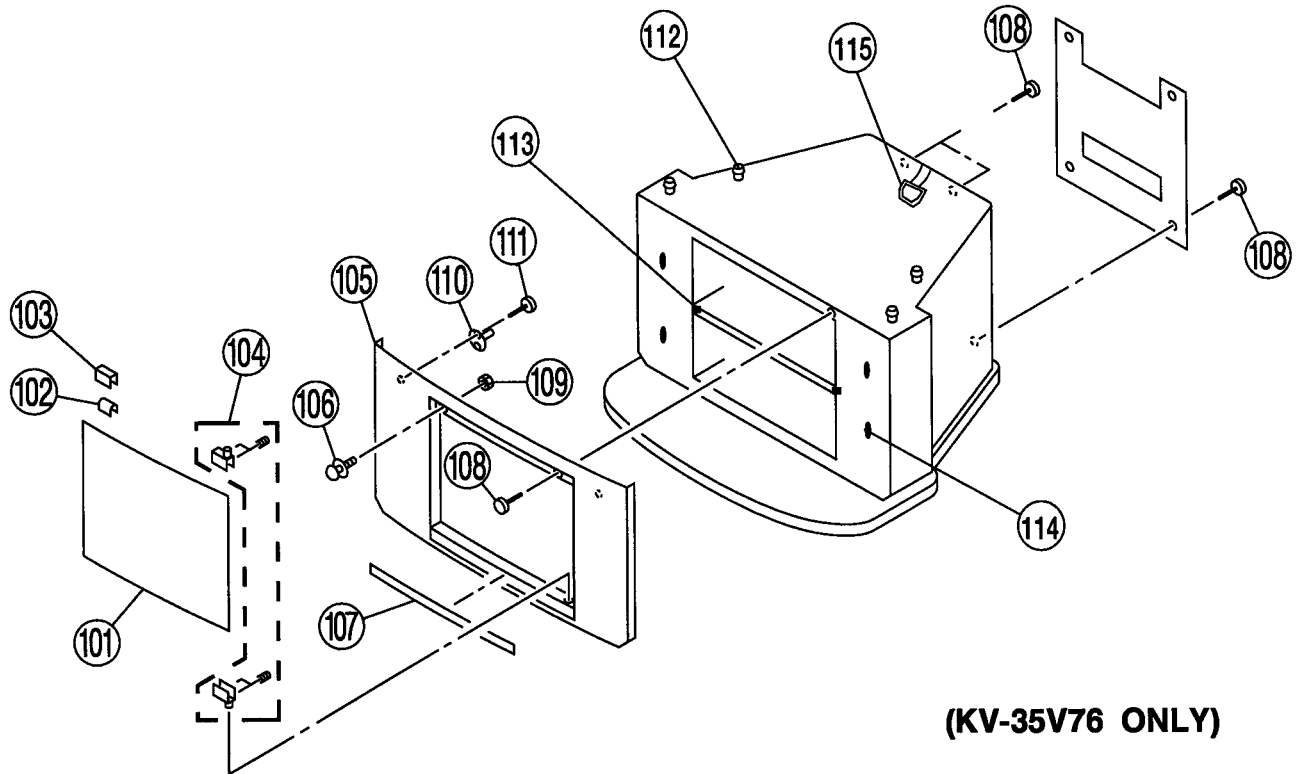

(KV-35V76 ONLY)

REF.NO.	PART NO.	DESCRIPTION	REMARK
101	X-4033-459-1	DOOR ASSY, GLASS	
102	2-352-981-01	SPACER	
103	2-359-505-01	RETAINER, MAGNET	
104	4-041-362-01	HINGE SET	
105	4-052-922-01	COVER, FRONT	
106	4-032-322-02	MAGNET, PUSH	
107 *	4-052-919-01	PANEL, FRONT	
108	4-041-164-11	SCREW (4X20), TAPPING	
109	4-046-172-01	NUT, HEXAGON HEAD	
110	4-843-806-00	STRIKE	
111	7-685-648-79	SCREW 93X12) TAPPING +BV	
112	4-054-376-01	WASHER (4)	
113	4-041-162-01	PIN RACK (4)	
114	4-838-438-02	LATCH (4)	
115	X-4033-016-1	BUCKLE ASSY	

P

SECTION 7 ELECTRICAL PARTS LIST

Note:

The components identified by shading and mark Δ are critical for safety. Replace only with part number specified.

Note:

Les composants identifiés par un trame et une marque Δ sont critiques pour la sécurité. Ne les remplacer que par une pièce portant le numéro spécifié.

The components identified by Δ in this manual have been carefully factory-selected for each set in order to satisfy regulations regarding X-ray radiation. Should replacement be required, replace only with the value originally used.

- Items marked "*" are not stocked since they are seldom required for routine service. Some delay should be anticipated when ordering these items.
- All variable and adjustable resistors have characteristic curve B, unless otherwise noted.

RESISTORS

- All resistors are in ohms
- F : nonflammable

CAPACITORS

- MF : μ F

INDUCTORSUH : μ H

When indicating parts by reference number, please include the board name

REF.NO.	PART NO.	DESCRIPTION	REMARK	REF.NO.	PART NO.	DESCRIPTION	REMARK
P							
* A-1195-103-A P BOARD, COMPLETE							
<u>CAPACITOR</u>							
C3301	1-163-017-00	CERAMIC CHIP	0.0047MF 10% 50V	C3346	1-163-251-11	CERAMIC CHIP	100PF 5% 50V
C3302	1-164-346-11	CERAMIC CHIP	1MF 16V	C3347	1-126-960-11	ELECT	1MF 20% 50V
C3303	1-163-038-91	CERAMIC CHIP	0.1MF 25V	C3348	1-126-967-11	ELECT	47MF 20% 16V
C3304	1-126-960-11	ELECT	1MF 20% 50V	C3349	1-163-121-00	CERAMIC CHIP	150PF 5% 50V
C3305	1-163-038-91	CERAMIC CHIP	0.1MF 25V	C3350	1-164-004-11	CERAMIC CHIP	0.1MF 10% 25V
C3306	1-126-967-11	ELECT	47MF 20% 16V	C3351	1-163-251-11	CERAMIC CHIP	100PF 5% 50V
C3307	1-163-038-91	CERAMIC CHIP	0.1MF 25V	<u>CONNECTOR</u>			
C3308	1-163-231-11	CERAMIC CHIP	15PF 5% 50V	CN3301*	1-764-816-11	CONNECTOR, BOARD TO BOARD 20P	
C3309	1-163-017-00	CERAMIC CHIP	0.0047MF 10% 50V	<u>IC</u>			
C3310	1-164-004-11	CERAMIC CHIP	0.1MF 10% 25V	IC3301	8-759-366-24	IC TDA8315T/N3A-T	
C3313	1-163-038-91	CERAMIC CHIP	0.1MF 25V	IC3302	8-759-231-53	IC TA7805S	
C3314	1-163-038-91	CERAMIC CHIP	0.1MF 25V	IC3303	8-759-438-61	IC SDA9288X-A141	
C3315	1-164-346-11	CERAMIC CHIP	1MF 16V	<u>COIL</u>			
C3319	1-163-031-11	CERAMIC CHIP	0.01MF 50V	L3301	1-408-413-00	INDUCTOR	22UH
C3320	1-126-960-11	ELECT	1MF 20% 50V	L3302	1-410-473-11	INDUCTOR	18UH
C3321	1-163-239-11	CERAMIC CHIP	33PF 5% 50V	L3303	1-408-418-00	INDUCTOR	56UH
C3322	1-163-239-11	CERAMIC CHIP	33PF 5% 50V	<u>TRANSISTOR</u>			
C3323	1-163-031-11	CERAMIC CHIP	0.01MF 50V	Q3301	8-729-422-27	TRANSISTOR 2SD601A-Q	
C3324	1-126-967-11	ELECT	47MF 20% 16V	Q3305	8-729-216-22	TRANSISTOR 2SA1162-G	
C3325	1-163-038-91	CERAMIC CHIP	0.1MF 25V	Q3306	8-729-216-22	TRANSISTOR 2SA1162-G	
C3326	1-163-038-91	CERAMIC CHIP	0.1MF 25V	Q3307	8-729-216-22	TRANSISTOR 2SA1162-G	
C3327	1-163-038-91	CERAMIC CHIP	0.1MF 25V	Q3308	8-729-422-27	TRANSISTOR 2SD601A-Q	
C3328	1-126-967-11	ELECT	47MF 20% 16V	Q3310	8-729-422-27	TRANSISTOR 2SD601A-Q	
C3329	1-126-967-11	ELECT	47MF 20% 16V	Q3312	8-729-216-22	TRANSISTOR 2SA1162-G	
C3330	1-163-031-11	CERAMIC CHIP	0.01MF 50V	Q3313	8-729-422-27	TRANSISTOR 2SD601A-Q	
C3331	1-126-967-11	ELECT	47MF 20% 16V	<u>RESISTOR</u>			
C3332	1-104-664-11	ELECT	47MF 20% 25V	R3301	1-216-075-00	METAL GLAZE	12K 5% 1/10W
C3333	1-164-695-11	CERAMIC CHIP	0.0022MF 5% 50V	R3302	1-216-043-91	METAL GLAZE	560 5% 1/10W
C3334	1-163-031-11	CERAMIC CHIP	0.01MF 50V	R3303	1-216-295-91	CONDUCTOR, CHIP	(2012)
C3335	1-163-038-91	CERAMIC CHIP	0.1MF 25V	R3304	1-216-043-91	METAL GLAZE	560 5% 1/10W
C3336	1-163-038-91	CERAMIC CHIP	0.1MF 25V	R3306	1-215-882-00	METAL OXIDE	22 5% 2W F
C3337	1-164-005-11	CERAMIC CHIP	0.47MF 25V	R3307	1-216-097-91	METAL GLAZE	100K 5% 1/10W
C3338	1-163-141-00	CERAMIC CHIP	0.001MF 5% 50V	R3308	1-216-051-00	METAL GLAZE	1.2K 5% 1/10W
C3340	1-163-031-11	CERAMIC CHIP	0.01MF 50V	R3309	1-216-051-00	METAL GLAZE	1.2K 5% 1/10W

Note: The components identified by shading and mark Δ are critical for safety. Replace only with part number specified.

Note: Les composants identifiés par un trame et une marque Δ sont critiques pour la sécurité. Ne les remplacer que par une pièce portant le numéro spécifié.



REF.NO.	PART NO.	DESCRIPTION	REMARK
R3310	1-216-689-11	METAL GLAZE	39K 5% 1/10W
R3311	1-216-689-11	METAL GLAZE	39K 5% 1/10W
R3312	1-216-037-00	METAL GLAZE	330 5% 1/10W
R3313	1-216-041-00	METAL GLAZE	470 5% 1/10W
R3314	1-216-041-00	METAL GLAZE	470 5% 1/10W
R3315	1-216-041-00	METAL GLAZE	470 5% 1/10W
R3316	1-216-053-00	METAL GLAZE	1.5K 5% 1/10W
R3319	1-216-053-00	METAL GLAZE	1.5K 5% 1/10W
R3321	1-216-053-00	METAL GLAZE	1.5K 5% 1/10W
R3322	1-216-065-00	METAL GLAZE	4.7K 5% 1/10W
R3323	1-216-065-00	METAL GLAZE	4.7K 5% 1/10W
R3324	1-216-065-00	METAL GLAZE	4.7K 5% 1/10W
R3326	1-216-037-00	METAL GLAZE	330 5% 1/10W
R3327	1-216-031-00	METAL GLAZE	180 5% 1/10W
R3328	1-216-037-00	METAL GLAZE	330 5% 1/10W
R3329	1-216-069-00	METAL GLAZE	6.8K 5% 1/10W
R3330	1-216-035-00	METAL GLAZE	270 5% 1/10W
R3331	1-216-073-00	METAL GLAZE	10K 5% 1/10W
R3332	1-216-041-00	METAL GLAZE	470 5% 1/10W
R3337	1-216-033-00	METAL GLAZE	220 5% 1/10W
R3338	1-216-033-00	METAL GLAZE	220 5% 1/10W
R3339	1-216-041-00	METAL GLAZE	470 5% 1/10W
R3340	1-216-041-00	METAL GLAZE	470 5% 1/10W
R3341	1-216-057-00	METAL GLAZE	2.2K 5% 1/10W
R3342	1-216-057-00	METAL GLAZE	2.2K 5% 1/10W
R3343	1-216-049-91	METAL GLAZE	1K 5% 1/10W
R3346	1-216-049-91	METAL GLAZE	1K 5% 1/10W
R3351	1-216-295-91	CONDUCTOR, CHIP (2012)	
R3352	1-216-049-91	METAL GLAZE	1K 5% 1/10W
R3358	1-216-047-91	METAL GLAZE	820 5% 1/10W
R3359	1-216-047-91	METAL GLAZE	820 5% 1/10W
R3360	1-216-053-00	METAL GLAZE	1.5K 5% 1/10W
R3361	1-216-053-00	METAL GLAZE	1.5K 5% 1/10W
R3362	1-216-029-00	METAL GLAZE	150 5% 1/10W
R3363	1-216-031-00	METAL GLAZE	180 5% 1/10W
R3364	1-216-035-00	METAL GLAZE	270 5% 1/10W
R3365	1-216-105-91	METAL GLAZE	220K 5% 1/10W
R3366	1-216-105-91	METAL GLAZE	220K 5% 1/10W
R3367	1-216-095-00	METAL GLAZE	82K 5% 1/10W
R3368	1-216-103-00	METAL GLAZE	180K 5% 1/10W
R3369	1-216-101-00	METAL GLAZE	150K 5% 1/10W
R3370	1-216-041-00	METAL GLAZE	470 5% 1/10W
R3371	1-216-095-00	METAL GLAZE	82K 5% 1/10W
R3372	1-216-041-00	METAL GLAZE	470 5% 1/10W
R3373	1-216-035-00	METAL GLAZE	270 5% 1/10W

CRYSTAL

X3301	1-567-505-11	OSCILLATOR, CRYSTAL
X3302	1-760-095-21	VIBRATOR, CRYSTAL

REF.NO.	PART NO.	DESCRIPTION	REMARK
---------	----------	-------------	--------



- * A-1297-720-A AV BOARD, COMPLETE (EXCEPT KV-32V26)
- * A-1297-850-A AV BOARD, COMPLETE (KV-32V36)

CAPACITOR

C101	1-126-960-11	ELECT	1MF	20% 50V
				(except KV-32V26)
C102	1-164-161-11	CERAMIC CHIP	0.0022MF	10% 50V
				(except KV-32V26)
C104	1-126-964-11	ELECT	10MF	20% 50V
				(except KV-32V26)
C106	1-104-664-11	ELECT	47MF	20% 25V
				(except KV-32V26)
C108	1-126-933-11	ELECT	100MF	20% 16V
				(except KV-32V26)
C109	1-163-259-91	CERAMIC CHIP	220PF	5% 50V
				(except KV-32V26)
C110	1-104-760-11	CERAMIC CHIP	0.047MF	10% 50V
				(except KV-32V26)
C111	1-126-960-11	ELECT	1MF	20% 50V
				(except KV-32V26)
C113	1-126-934-11	ELECT	220MF	20% 16V
				(except KV-32V26)
C1902	1-126-964-11	ELECT	10MF	20% 50V
C1903	1-102-129-00	CERAMIC	0.01MF	10% 50V
C1904	1-102-129-00	CERAMIC	0.01MF	10% 50V
C1905	1-126-964-11	ELECT	10MF	20% 50V
C1906	1-102-129-00	CERAMIC	0.01MF	10% 50V
C1907	1-126-964-11	ELECT	10MF	20% 50V
C1908	1-102-074-00	CERAMIC	0.001MF	10% 50V
C1909	1-102-074-00	CERAMIC	0.001MF	10% 50V
C1910	1-164-232-11	CERAMIC CHIP	0.01MF	10% 50V
C1911	1-164-232-11	CERAMIC CHIP	0.01MF	10% 50V

CONNECTOR

CN101	1-573-301-21	CONNECTOR, BOARD TO BOARD 20P
CN102	1-573-979-21	CONNECTOR, BOARD TO BOARD 11P
CN103	* 1-564-507-11	PLUG, CONNECTOR 4P (except KV-32V26)
CN106	* 1-564-506-11	PLUG, CONNECTOR 3P

DIODE

D101	8-719-109-89	DIODE RD5.6ESB2 (except KV-32V26)
D103	8-719-991-33	DIODE 1SS133T-77
D104	8-719-991-33	DIODE 1SS133T-77 (except KV-32V26)

IC

IC1901	8-752-058-68	IC CXA1315M
IC1902	8-759-981-61	IC LM2901M
IC1903	8-759-356-27	IC NJM2129M-TE2

AV

Note: The components identified by shading and mark Δ are critical for safety. Replace only with part number specified.

Note: Les composants identifiés par un trame et une marque Δ sont critiques pour la sécurité. Ne les remplacer que par une pièce portant le numéro spécifié.

REF.NO.	PART NO.	DESCRIPTION	REMARK	REF.NO.	PART NO.	DESCRIPTION	REMARK
COIL				R1905	1-216-073-00	METAL GLAZE	10K 5% 1/10W
L102	1-410-470-11	INDUCTOR	10UH (except KV-32V26)	R1906	1-216-025-91	METAL GLAZE	100 5% 1/10W
L105	1-408-421-00	INDUCTOR	100UH (except KV-32V26)	R1907	1-216-089-91	METAL GLAZE	47K 5% 1/10W
TRANSISTOR				R1908	1-216-073-00	METAL GLAZE	10K 5% 1/10W
Q101	8-729-119-78	TRANSISTOR 2SC2785-HFE	(except KV-32V26)	R1909	1-216-041-00	METAL GLAZE	470 5% 1/10W
Q103	8-729-216-22	TRANSISTOR 2SA1162-G	(except KV-32V26)	R1910	1-216-073-00	METAL GLAZE	10K 5% 1/10W
Q104	8-729-216-22	TRANSISTOR 2SA1162-G	(except KV-32V26)	R1911	1-216-073-00	METAL GLAZE	10K 5% 1/10W
Q105	8-729-216-22	TRANSISTOR 2SA1162-G	(except KV-32V26)	R1915	1-216-073-00	METAL GLAZE	10K 5% 1/10W
Q1901	8-729-216-22	TRANSISTOR 2SA1162-G		R1916	1-216-073-00	METAL GLAZE	10K 5% 1/10W
Q1902	8-729-216-22	TRANSISTOR 2SA1162-G		R1922	1-216-043-91	METAL GLAZE	560 5% 1/10W
Q1906	8-729-216-22	TRANSISTOR 2SA1162-G		R1923	1-216-043-91	METAL GLAZE	560 5% 1/10W
Q1908	8-729-216-22	TRANSISTOR 2SA1162-G		R1928	1-216-041-00	METAL GLAZE	470 5% 1/10W
Q1911	8-729-422-27	TRANSISTOR 2SD601A-Q		R1929	1-216-089-91	METAL GLAZE	47K 5% 1/10W
Q1912	8-729-422-27	TRANSISTOR 2SD601A-Q		R1930	1-216-073-00	METAL GLAZE	10K 5% 1/10W
Q1914	8-729-216-22	TRANSISTOR 2SA1162-G		R1931	1-216-025-91	METAL GLAZE	100 5% 1/10W
Q1916	8-729-422-27	TRANSISTOR 2SD601A-Q		R1932	1-216-073-00	METAL GLAZE	10K 5% 1/10W
Q1917	8-729-422-27	TRANSISTOR 2SD601A-Q		R1934	1-216-097-91	METAL GLAZE	100K 5% 1/10W
Q1918	8-729-422-27	TRANSISTOR 2SD601A-Q		R1935	1-216-295-91	CONDUCTOR, CHIP (2012)	
Q1919	8-729-422-27	TRANSISTOR 2SD601A-Q		R1936	1-208-804-11	METAL GLAZE	8.2K 0.50% 1/10W
RESISTOR				R1937	1-208-790-11	METAL GLAZE	2.2K 0.50% 1/10W
R101	1-216-065-00	METAL GLAZE	4.7K 5% 1/10W (except KV-32V26)	R1940	1-216-065-00	METAL GLAZE	4.7K 5% 1/10W
R102	1-216-083-00	METAL GLAZE	27K 5% 1/10W (except KV-32V26)	R2901	1-208-808-11	METAL GLAZE	12K 0.50% 1/10W
R103	1-216-689-11	METAL GLAZE	39K 5% 1/10W (except KV-32V26)	R2903	1-216-065-00	METAL GLAZE	4.7K 5% 1/10W
R104	1-216-045-00	METAL GLAZE	680 5% 1/10W (except KV-32V26)	R2904	1-216-033-00	METAL GLAZE	220 5% 1/10W
R106	1-216-081-00	METAL GLAZE	22K 5% 1/10W (except KV-32V26)	R2905	1-216-033-00	METAL GLAZE	220 5% 1/10W
R107	1-216-081-00	METAL GLAZE	22K 5% 1/10W (except KV-32V26)	R2906	1-216-033-00	METAL GLAZE	220 5% 1/10W
R108	1-216-081-00	METAL GLAZE	22K 5% 1/10W (except KV-32V26)	R2907	1-216-065-00	METAL GLAZE	4.7K 5% 1/10W
R109	1-216-081-00	METAL GLAZE	22K 5% 1/10W (except KV-32V26)	R2908	1-216-073-00	METAL GLAZE	10K 5% 1/10W
R112	1-249-421-11	CARBON	2.2K 5% 1/4W (except KV-32V26)	R2909	1-216-073-00	METAL GLAZE	10K 5% 1/10W
R113	1-216-097-91	METAL GLAZE	100K 5% 1/10W (except KV-32V26)	R2910	1-216-073-00	METAL GLAZE	10K 5% 1/10W
R114	1-216-121-91	METAL GLAZE	1M 5% 1/10W (except KV-32V26)	R2911	1-216-061-00	METAL GLAZE	3.3K 5% 1/10W
R115	1-216-073-00	METAL GLAZE	10K 5% 1/10W (except KV-32V26)	R2912	1-249-425-11	CARBON	4.7K 5% 1/4W
R116	1-216-073-00	METAL GLAZE	10K 5% 1/10W (except KV-32V26)	R2913	1-216-073-00	METAL GLAZE	10K 5% 1/10W
R117	1-216-065-00	METAL GLAZE	4.7K 5% 1/10W (except KV-32V26)	R2914	1-216-073-00	METAL GLAZE	10K 5% 1/10W
R1904	1-216-073-00	METAL GLAZE	10K 5% 1/10W	R2916	1-216-073-00	METAL GLAZE	10K 5% 1/10W
				TUNER			
				TU101 Δ	8-598-339-00	TUNER BTF-LA402	(except KV-32V26)

Note: **The components identified by shading and mark Δ are critical for safety. Replace only with part number specified.**

Note: **Les composants identifiés par un trame et une marque Δ sont critiques pour la sécurité. Ne les remplacer que par une pièce portant le numéro spécifié.**

A

REF.NO. PART NO. DESCRIPTION REMARK

A

* A-1298-062-A A BOARD COMPLETE (KV-32V26)
 * A-1298-082-A A BOARD COMPLETE (KV-32V36/34V36C)
 * A-1298-087-A A BOARD COMPLETE (KV-35V36/37V36M)
 * A-1298-088-A A BOARD COMPLETE (KV-35V76)

* 4-051-927-01 CASE, SHIELD
 4-382-854-11 SCREW (M3X10), P, SW (+)

CAPACITOR

C001	1-163-259-91	CERAMIC CHIP	220PF	5%	50V
C003	1-104-760-11	CERAMIC CHIP	0.047MF	10%	50V
C005	1-126-960-11	ELECT	1MF	20%	50V
C009	1-126-967-11	ELECT	47MF	20%	50V
C010	1-163-033-91	CERAMIC CHIP	0.022MF		50V
C012	1-216-033-00	METAL GLAZE	220	5%	1/10W
C013	1-216-121-91	METAL GLAZE	1M	5%	1/10W
C014	1-164-161-11	CERAMIC CHIP	0.0022MF	10%	50V
C023	1-163-259-91	CERAMIC CHIP	220PF	5%	50V
C028	1-163-227-11	CERAMIC CHIP	10PF	0.5PF	50V
C029	1-163-227-11	CERAMIC CHIP	10PF	0.5PF	50V
C030	1-163-009-11	CERAMIC CHIP	0.001MF	10%	50V
C035	1-163-237-11	CERAMIC CHIP	27PF	5%	50V
C036	1-163-231-11	CERAMIC CHIP	15PF	5%	50V
C037	1-163-243-11	CERAMIC CHIP	47PF	5%	50V
C038	1-163-243-11	CERAMIC CHIP	47PF	5%	50V
C039	1-163-243-11	CERAMIC CHIP	47PF	5%	50V
C040	1-163-243-11	CERAMIC CHIP	47PF	5%	50V
C051	1-164-161-11	CERAMIC CHIP	0.0022MF	10%	50V
C053	1-164-232-11	CERAMIC CHIP	0.01MF	10%	50V
C056	1-163-243-11	CERAMIC CHIP	47PF	5%	50V
C061	1-163-033-91	CERAMIC CHIP	0.022MF		50V
C062	1-163-033-91	CERAMIC CHIP	0.022MF		50V
C063	1-126-935-11	ELECT	470MF	20%	16V
C071	1-164-096-11	CERAMIC	0.01MF		50V
C072	1-164-161-11	CERAMIC CHIP	0.0022MF	10%	50V
C075	1-107-823-11	CERAMIC CHIP	0.47MF	10%	16V
C353	1-163-231-11	CERAMIC CHIP	15PF	5%	50V
C354	1-163-133-00	CERAMIC CHIP	470PF	5%	50V
C355	1-126-959-11	ELECT	0.47MF	20%	50V
C356	1-126-963-11	ELECT	4.7MF	20%	50V
C357	1-126-959-11	ELECT	0.47MF	20%	50V
C358	1-164-232-11	CERAMIC CHIP	0.01MF	10%	50V
C359	1-126-933-11	ELECT	100MF	20%	16V
C363	1-164-232-11	CERAMIC CHIP	0.01MF	10%	50V
C364	1-164-232-11	CERAMIC CHIP	0.01MF	10%	50V
C365	1-164-232-11	CERAMIC CHIP	0.01MF	10%	50V
C366	1-137-399-11	FILM	0.1MF	5%	50V

REF.NO. PART NO. DESCRIPTION REMARK

C367	1-137-399-11	FILM	0.1MF	5%	50V
C368	1-137-399-11	FILM	0.1MF	5%	50V
C369	1-163-243-11	CERAMIC CHIP	47PF	5%	50V
C370	1-163-037-11	CERAMIC CHIP	0.022MF	10%	50V
C371	1-163-141-00	CERAMIC CHIP	0.001MF	5%	50V
C372	1-126-959-11	ELECT	0.47MF	20%	50V
C373	1-126-960-11	ELECT	1MF	20%	50V
C376	1-126-964-11	ELECT	10MF	20%	50V
C377	1-137-399-11	FILM	0.1MF	5%	50V
C378	1-136-244-11	FILM	0.1MF	5%	50V
C379	1-164-232-11	CERAMIC CHIP	0.01MF	10%	50V
C380	1-126-935-11	ELECT	470MF	20%	16V
C381	1-163-003-11	CERAMIC CHIP	330PF	10%	50V
C383	1-137-399-11	FILM	0.1MF	5%	50V
C385	1-164-182-11	CERAMIC CHIP	0.0033MF	10%	50V
C386	1-164-232-11	CERAMIC CHIP	0.01MF	10%	50V
C387	1-126-961-11	ELECT	2.2MF	20%	50V
C388	1-126-959-11	ELECT	0.47MF	20%	50V
C390	1-126-960-11	ELECT	1MF	20%	50V
C391	1-163-017-00	CERAMIC CHIP	0.0047MF	10%	50V
C392	1-163-251-11	CERAMIC CHIP	100PF	5%	50V
C461	1-126-964-11	ELECT	10MF	20%	50V (KV-32V26/35V36/37V36M/35V76)
C461	1-126-964-11	ELECT	33MF	20%	25V (KV-32V36/34V36C)
C462	1-126-961-11	ELECT	2.2MF	20%	50V
C463	1-126-961-11	ELECT	2.2MF	20%	50V
C464	1-163-017-00	CERAMIC CHIP	.0047MF	10%	50V (KV-32V36/34V36C)
C466	1-104-666-11	ELECT	220MF	20%	25V
C467	1-163-017-00	CERAMIC CHIP	.0047MF	10%	50V (KV-32V36/34V36C)
C468	1-104-664-11	ELECT	47MF	20%	25V
C470	1-126-961-11	ELECT	2.2MF	20%	50V
C471	1-104-666-11	ELECT	220MF	20%	25V
C472	1-136-173-00	FILM	0.47MF	5%	50V
C473	1-136-169-00	FILM	0.22MF	5%	50V
C474	1-126-942-61	ELECT	1000MF	20%	25V
C475	1-136-169-00	FILM	0.22MF	5%	50V
C476	1-126-942-61	ELECT	1000MF	20%	25V (KV-32V36/35V36/37V36M)
C477	1-126-942-61	ELECT	1000MF	20%	25V (KV-32V36/35V36/37V36M)
C478	1-126-934-11	ELECT	220MF	20%	16V (KV-32V36/34V36C/35V76)
C478	1-126-965-11	ELECT	22MF	20%	50V (KV-35V36/37V36M)
C479	1-126-964-11	ELECT	10MF	20%	50V (KV-35V76)
C479	1-126-961-11	ELECT	2.2MF	20%	50V (KV-35V36/37V36M)



Note: The components identified by shading and mark Δ are critical for safety. Replace only with part number specified.

Note: Les composants identifiés par un trame et une marque Δ sont critiques pour la sécurité. Ne les remplacer que par une pièce portant le numéro spécifié.

REF.NO.	PART NO.	DESCRIPTION	REMARK
C501	1-102-110-00	CERAMIC	220PF 10% 50V
C502	1-126-959-11	ELECT	0.47MF 20% 50V
C503	1-163-003-11	CERAMIC CHIP	330PF 10% 50V
C504	1-102-212-00	CERAMIC	820PF 10% 500V
C505	1-102-002-00	CERAMIC	680PF 10% 500V
C506	1-106-383-00	MYLAR	0.047MF 10% 200V
C507 Δ	1-162-116-00	CERAMIC	680PF 10% 2KV
C508	1-102-244-00	CERAMIC	220PF 10% 500V
C509	1-162-116-00	CERAMIC	680PF 10% 2KV
C510	1-137-150-11	MYLAR	0.01MF 10% 100V
C511 Δ	1-115-460-11	FILM	0.022MF 3% 1.2KV
C513 Δ	1-129-720-00	FILM	0.033MF 5% 630V (KV-35V36/37V36M/35V76)
C513 Δ	1-130-895-00	FILM	0.056MF 5% 400V (KV-32V26/32V36M/34V36C)
C514 Δ	1-136-540-11	FILM	0.82MF 5% 200V (KV-35V36/37V36M/35V76)
C514 Δ	1-104-844-11	FILM	0.62MF 5% 200V (KV-32V26/32V36M/34V36C)
C515	1-106-343-00	MYLAR	0.001MF 10% 100V
C516	1-115-461-11	FILM	2MF 5% 200V
C517	1-107-649-11	ELECT	2.2MF 20% 250V
C518	1-106-395-00	MYLAR	0.15MF 10% 200V
C519	1-162-815-11	CERAMIC	47PF 5% 500V
C520	1-164-645-11	CERAMIC	1000PF 10% 500V
C521	1-164-161-11	CERAMIC CHIP	0.0022MF 10% 50V
C522	1-126-960-11	ELECT	1MF 20% 50V
C525	1-102-244-00	CERAMIC	220PF 10% 500V
C526	1-107-662-11	ELECT	22MF 20% 250V
C527	1-162-116-00	CERAMIC	680PF 10% 2KV
C528	1-164-161-11	CERAMIC CHIP	0.0022MF 10% 50V
C529	1-128-551-11	ELECT	22MF 20% 25V
C530	1-137-366-11	FILM	0.0022MF 5% 50V
C531	1-126-965-11	ELECT	22MF 20% 50V
C532	1-126-965-11	ELECT	22MF 20% 50V
C537	1-126-942-61	ELECT	1000MF 20% 25V (KV-35V36/37V36M/35V76)
C537	1-126-941-11	ELECT	470MF 20% 25V (KV-32V26/32V36/34V36C)
C539 Δ	1-107-914-11	ELECT	1000MF 20% 25V (KV-35V36/37V36M/35V76)
C539 Δ	1-126-935-11	ELECT	470MF 20% 16V (KV-32V26/32V36/34V36C)
C540	1-123-024-21	ELECT	33MF 160V
C541	1-128-560-11	ELECT	22MF 20% 100V
C542	1-106-383-00	MYLAR	0.047MF 10% 200V (KV-35V36/37V36M/35V76)
C543	1-162-131-11	CERAMIC	220PF 10% 2KV (KV-35V36/37V36M/35V76)
C545	1-106-387-00	MYLAR	0.068MF 10% 200V
C546	1-106-343-00	MYLAR	0.001MF 10% 100V

REF.NO.	PART NO.	DESCRIPTION	REMARK
C547	1-106-343-00	MYLAR	0.001MF 10% 100V
C551	1-163-037-11	CERAMIC CHIP	0.022MF 10% 50V
C561	1-126-967-11	ELECT	47MF 20% 50V
C563	1-126-923-11	ELECT	220MF 20% 10V
C564	1-126-960-11	ELECT	1MF 20% 50V
C565	1-126-969-11	ELECT	220MF 20% 50V
C566	1-126-964-11	ELECT	10MF 20% 50V
C568	1-136-169-00	FILM	0.22MF 5% 50V
C571	1-104-664-11	ELECT	47MF 20% 25V (KV-32V26/32V36/34V36C)
C1002	1-126-964-11	ELECT	10MF 20% 50V
C1101	1-126-768-11	ELECT	2200MF 20% 16V
C1103	1-126-965-11	ELECT	22MF 20% 50V
C1104	1-126-967-11	ELECT	47MF 20% 16V
C1105	1-126-967-11	ELECT	47MF 20% 16V
C1106	1-126-964-11	ELECT	10MF 20% 50V
C1107	1-163-037-11	CERAMIC CHIP	0.022MF 10% 50V
C1108	1-126-960-11	ELECT	1MF 20% 50V
C1109	1-126-964-11	ELECT	10MF 20% 50V
C1110	1-163-227-11	CERAMIC CHIP	10PF 0.5PF 50V
C1111	1-163-227-11	CERAMIC CHIP	10PF 0.5PF 50V
C1112	1-163-227-11	CERAMIC CHIP	10PF 0.5PF 50V
C1244	1-126-959-11	ELECT	0.47MF 20% 50V
C1245	1-126-959-11	ELECT	0.47MF 20% 50V
C1351	1-163-251-11	CERAMIC CHIP	100PF 5% 50V
C1352	1-126-933-11	ELECT	100MF 20% 16V
C1353	1-163-037-11	CERAMIC CHIP	0.022MF 10% 50V
C1354	1-216-295-91	CONDUCTOR, CHIP	(2012)
C1401	1-126-959-11	ELECT	0.47MF 20% 50V
C1402	1-126-964-11	ELECT	10MF 20% 50V
C1403	1-126-959-11	ELECT	0.47MF 20% 50V
C1404	1-165-319-11	CERAMIC CHIP	0.1MF 50V
C1405	1-165-319-11	CERAMIC CHIP	0.1MF 50V
C1406	1-165-319-11	CERAMIC CHIP	0.1MF 50V
C1407	1-165-319-11	CERAMIC CHIP	0.1MF 50V
C1408	1-164-161-11	CERAMIC CHIP	0.0022MF 10% 50V (KV-32V26/35V36/35V76/37V36M)
C1408	1-164-182-11	CERAMIC CHIP	0.0033MF 10% 50V (KV-32V36/34V36C)
C1409	1-164-161-11	CERAMIC CHIP	0.0022MF 10% 50V (KV-32V26/35V36/35V76/37V36M)
C1409	1-164-182-11	CERAMIC CHIP	0.0033MF 10% 50V (KV-32V36/34V36C)
C1410	1-164-161-11	CERAMIC CHIP	0.0022MF 10% 50V (KV-32V26/35V36/35V76/37V36M)
C1410	1-164-182-11	CERAMIC CHIP	0.0033MF 10% 50V (KV-32V36/34V36C)
C1411	1-164-161-11	CERAMIC CHIP	0.0022MF 10% 50V (KV-32V26/35V36/35V76/37V36M)
C1408	1-164-182-11	CERAMIC CHIP	0.0033MF 10% 50V (KV-32V36/34V36C)

Note: The components identified by shading and mark Δ are critical for safety. Replace only with part number specified.

Note: Les composants identifiés par un trame et une marque Δ sont critiques pour la sécurité. Ne les remplacer que par une pièce portant le numéro spécifié.



REF.NO.	PART NO.	DESCRIPTION	REMARK
C1412	1-126-961-11	ELECT	2.2MF 20% 50V
C1413	1-126-961-11	ELECT	2.2MF 20% 50V
C1414	1-164-489-11	CERAMIC CHIP	0.22MF 10% 16V
C1415	1-126-965-11	ELECT	22MF 20% 50V
C1416	1-126-933-11	ELECT	100MF 20% 16V
C1417	1-126-767-11	ELECT	1000MF 20% 16V
C1420	1-164-005-11	CERAMIC CHIP	0.47MF 25V
C1501	1-115-462-11	FILM	0.12MF 5% 200V (KV-32V26/32V36/34V36C)
CONNECTOR			
CN270	1-573-298-11	CONNECTOR, BOARD TO BOARD	20P
CN271	1-573-978-21	CONNECTOR, BOARD TO BOARD	11P
CN351	* 1-564-509-11	PLUG, CONNECTOR	6P
CN461	* 1-564-510-11	PLUG, CONNECTOR	7P (KV-32V36/34V36C/35V76)
CN461	* 1-564-507-11	PLUG, CONNECTOR	4P (KV-32V26/35V36/37V36M)
CN501	* 1-580-798-11	CONNECTOR PIN (DY)	6P
CN502	* 1-508-784-00	PIN, CONNECTOR (5MM PITCH)	1P (KV-35V36/37V36M/35V76)
CN503	* 1-564-507-11	PLUG, CONNECTOR	4P
CN1001	* 1-564-512-11	PLUG, CONNECTOR	9P
CN1101	1-573-298-11	CONNECTOR, BOARD TO BOARD	20P
CN1103	1-573-979-21	CONNECTOR, BOARD TO BOARD	11P
CN1231	1-564-511-11	PLUG, CONNECTOR	8P
CN1641	* 1-564-515-11	PLUG, CONNECTOR	12P
CN1941	1-564-511-11	PLUG, CONNECTOR	8P (KV-35V36/37V36M/35V76)
CN1941	1-564-508-11	PLUG, CONNECTOR	5P (KV-32V36/34V36C)
CN3001	1-573-298-11	CONNECTOR, BOARD TO BOARD	20P
DIODE			
D001	8-719-991-33	DIODE 1SS133T-77	
D002	8-719-109-89	DIODE RD5.6ESB2	
D003	8-719-991-33	DIODE 1SS133T-77	
D004	8-719-110-17	DIODE RD10ESB2	
D011	8-719-983-14	DIODE MTZJ-T-77-3.9	
D013	8-719-991-33	DIODE 1SS133T-77	
D014	8-719-991-33	DIODE 1SS133T-77	
D015	8-719-991-33	DIODE 1SS133T-77	
D353	8-719-991-33	DIODE 1SS133T-77	
D356	8-719-991-33	DIODE 1SS133T-77	
D360	8-719-110-17	DIODE RD10ESB2	
D362	8-719-991-33	DIODE 1SS133T-77	
D368	8-719-991-33	DIODE 1SS133T-77	
D462	8-719-991-33	DIODE 1SS133T-77	
D501	8-719-109-89	DIODE RD5.6ESB2	
D502	8-719-945-80	DIODE ERC06-15S	
D503	8-719-945-80	DIODE ERC06-15S	
D504	8-719-900-26	DIODE ERD29-08J	
D505	8-719-908-03	DIODE GP08D	
D506	8-719-908-03	DIODE GP08D	

REF.NO.	PART NO.	DESCRIPTION	REMARK
D507	8-719-991-33	DIODE 1SS133T-77	
D515	8-719-302-43	DIODE EL1Z	
D516	8-719-991-33	DIODE 1SS133T-77	
D518	8-719-991-33	DIODE 1SS133T-77	
D519	Δ 8-719-302-43	DIODE EL1Z	
D520	8-719-991-33	DIODE 1SS133T-77	
D521	8-719-921-63	DIODE MTZJ-7.5B	
D530	8-719-979-85	DIODE EGP20G	
D531	8-719-979-85	DIODE EGP20G	
D534	8-719-302-43	DIODE EL1Z	
D535	8-719-028-72	DIODE RGP02-17PKG23	(KV-35V36/37V36M/35V76)
D561	8-719-908-03	DIODE GP08D	
D562	8-719-991-33	DIODE 1SS133T-77	
D1102	8-719-982-24	DIODE MTZJ-33A	
D1103	8-719-109-89	DIODE RD5.6ESB2	
D1248	8-719-981-99	DIODE MTZJ-3.3	
D1263	8-719-110-17	DIODE RD10ESB2	
D1264	8-719-110-17	DIODE RD10ESB2	
FERRITE BEAD			
FB501	1-410-396-41	FERRITE BEAD INDUCTOR	0.45UH
FB502	1-410-397-21	FERRITE BEAD INDUCTOR	1.1UH
FB503	1-410-397-21	FERRITE BEAD INDUCTOR	1.1UH
IC			
IC001	8-752-880-88	IC CXP85840-002S	
IC002	8-759-354-28	IC ST24C02FM6TR	
IC351	8-752-076-76	IC CXA2025AS	
IC461	8-759-980-43	IC TDA2009A	
IC501	8-759-700-07	IC NJM2903M	
IC561	8-759-192-71	IC STV9379	(KV-35V36/37V36M/35V76)
IC561	8-759-980-58	IC STV9379	(KV-32V26/32V36/34V36C)
IC1001	8-752-058-68	IC CXA1315M	
IC1401	8-759-369-39	IC BH3856FS-E2	
IC1402	8-759-100-96	IC UPC4558G2	
CHIP CONDUCTOR			
JR001	1-216-295-91	CONDUCTOR, CHIP	(2012)
JR164	1-216-295-91	CONDUCTOR, CHIP	(2012)
JR165	1-216-295-91	CONDUCTOR, CHIP	(2012)
JR240	1-216-295-91	CONDUCTOR, CHIP	(2012)
JR501	1-216-295-91	CONDUCTOR, CHIP	(2012) (KV-32V26/32V36/34V36C)
JR1351	1-216-295-91	CONDUCTOR, CHIP	(2012)
JR1352	1-216-295-91	CONDUCTOR, CHIP	(2012)
JR4101	1-216-295-91	CONDUCTOR, CHIP	(2012)
JR4108	1-216-295-91	CONDUCTOR, CHIP	(2012)
JR4110	1-216-295-91	CONDUCTOR, CHIP	(2012)



Note: The components identified by shading and mark Δ are critical for safety. Replace only with part number specified.

Note: Les composants identifiés par un trame et une marque Δ sont critiques pour la sécurité. Ne les remplacer que par une pièce portant le numéro spécifié.

REF.NO.	PART NO.	DESCRIPTION	REMARK
JR4114	1-216-295-91	CONDUCTOR, CHIP (2012)	
JR4116	1-216-295-91	CONDUCTOR, CHIP (2012)	
JR4120	1-216-295-91	CONDUCTOR, CHIP (2012)	
<u>COIL</u>			
L001	1-408-421-00	INDUCTOR	100UH
L002	1-408-421-00	INDUCTOR	100UH
L003	1-410-470-11	INDUCTOR	10UH
L004	1-410-470-11	INDUCTOR	10UH
L352	1-412-537-31	INDUCTOR	100UH
L461	1-408-424-00	INDUCTOR	180UH (KV-35V76)
L461	1-408-425-00	INDUCTOR	220UH (KV-35V36/37V36M)
L461	1-408-418-00	INDUCTOR	56UH (KV-32V36/34V36C)
L461	1-410-472-41	INDUCTOR	15UH (KV-32V26)
L501 Δ	1-409-861-11	COIL, HORIZONTAL LINEARITY	
L502	1-412-552-11	INDUCTOR	2.2MMH
L503	1-406-677-11	COIL, CHOKE	10MMH
L511	1-406-607-11	COIL, CHOKE	15MMH
L517	1-412-552-11	INDUCTOR	2.2MMH
L541	1-406-677-11	COIL, CHOKE	10MMH (KV-35V36/37V36M/35V76)
L1101	1-408-421-00	INDUCTOR	100UH
L1102	1-410-470-11	INDUCTOR	10UH
L1401	1-410-494-11	INDUCTOR	1MMH
<u>IC LINK</u>			
PS461 Δ	1-532-984-11	LINK, IC 2A/90V	
<u>TRANSISTOR</u>			
Q001	8-729-216-22	TRANSISTOR 2SA1162-G	
Q002	8-729-422-27	TRANSISTOR 2SD601A-Q	
Q003	8-729-422-27	TRANSISTOR 2SD601A-Q	
Q004	8-729-216-22	TRANSISTOR 2SA1162-G	
Q010	8-729-422-27	TRANSISTOR 2SD601A-Q	
Q011	8-729-422-27	TRANSISTOR 2SD601A-Q	
Q012	8-729-422-27	TRANSISTOR 2SD601A-Q	
Q013	8-729-422-27	TRANSISTOR 2SD601A-Q	
Q014	8-729-422-27	TRANSISTOR 2SD601A-Q	
Q015	8-729-422-27	TRANSISTOR 2SD601A-Q	
Q016	8-729-422-27	TRANSISTOR 2SD601A-Q	
Q017	8-729-216-22	TRANSISTOR 2SA1162-G	
Q301	8-729-216-22	TRANSISTOR 2SA1162-G	
Q302	8-729-216-22	TRANSISTOR 2SA1162-G	
Q303	8-729-216-22	TRANSISTOR 2SA1162-G	
Q354	8-729-422-27	TRANSISTOR 2SD601A-Q	
Q356	8-729-216-22	TRANSISTOR 2SA1162-G	
Q357	8-729-422-27	TRANSISTOR 2SD601A-Q (EXCEPT KV-32V26)	
Q358	8-729-422-27	TRANSISTOR 2SD601A-Q	
Q461	8-729-422-27	TRANSISTOR 2SD601A-Q	

REF.NO.	PART NO.	DESCRIPTION	REMARK
Q462	8-729-216-22	TRANSISTOR 2SA1162-G	
Q501	8-729-140-50	TRANSISTOR 2SC3209LK	
Q502 Δ	8-729-035-75	TRANSISTOR 2SC5148 (LBSONY)	
Q511 Δ	8-729-422-27	TRANSISTOR 2SD601A-Q	
Q512 Δ	8-729-809-29	TRANSISTOR 2SC4159-E	
Q551	8-729-216-22	TRANSISTOR 2SA1162-G	
Q552	8-729-422-27	TRANSISTOR 2SD601A-Q	
Q561	8-729-422-27	TRANSISTOR 2SD601A-Q	
Q562	8-729-422-27	TRANSISTOR 2SD601A-Q	
Q563	8-729-105-08	TRANSISTOR 2SA1330-06	
Q1102	8-729-119-78	TRANSISTOR 2SC2785-HFE	
Q1103	8-729-422-27	TRANSISTOR 2SD601A-Q	
Q1231	8-729-422-27	TRANSISTOR 2SD601A-Q	
Q1232	8-729-422-27	TRANSISTOR 2SD601A-Q	
<u>RESISTOR</u>			
R001	1-216-045-00	METAL GLAZE	680 5% 1/10W
R002	1-247-815-91	CARBON	220 5% 1/4W
R003	1-216-097-91	METAL GLAZE	100K 5% 1/10W
R004	1-216-121-91	METAL GLAZE	1M 5% 1/10W
R005	1-247-815-91	CARBON	220 5% 1/4W
R006	1-247-815-91	CARBON	220 5% 1/4W
R007	1-216-073-00	METAL GLAZE	10K 5% 1/10W
R008	1-247-815-91	CARBON	220 5% 1/4W
R009	1-216-073-00	METAL GLAZE	10K 5% 1/10W
R010	1-216-037-00	METAL GLAZE	330 5% 1/10W
R011	1-216-065-00	METAL GLAZE	4.7K 5% 1/10W
R012	1-216-033-00	METAL GLAZE	220 5% 1/10W
R013	1-216-065-00	METAL GLAZE	4.7K 5% 1/10W
R014	1-216-065-00	METAL GLAZE	4.7K 5% 1/10W
R015	1-216-073-00	METAL GLAZE	10K 5% 1/10W
R016	1-216-073-00	METAL GLAZE	10K 5% 1/10W
R019	1-249-425-11	CARBON	4.7K 5% 1/4W
R020	1-216-065-00	METAL GLAZE	4.7K 5% 1/10W
R022	1-249-429-11	CARBON	10K 5% 1/4W
R023	1-216-089-91	METAL GLAZE	47K 5% 1/10W
R025	1-163-010-11	CERAMIC CHIP	0.0012MF 10% 50V
R026	1-163-038-91	CERAMIC CHIP	0.1MF 25V
R028	1-249-417-11	CARBON	1K 5% 1/4W
R029	1-216-025-91	METAL GLAZE	100 5% 1/10W
R030	1-249-425-11	CARBON	4.7K 5% 1/4W
R031	1-247-815-91	CARBON	220 5% 1/4W
R032	1-247-815-91	CARBON	220 5% 1/4W
R034	1-247-815-91	CARBON	220 5% 1/4W
R035	1-247-815-91	CARBON	220 5% 1/4W
R036	1-216-049-91	METAL GLAZE	1K 5% 1/10W
R037	1-216-049-91	METAL GLAZE	1K 5% 1/10W
R038	1-216-049-91	METAL GLAZE	1K 5% 1/10W
R039	1-247-807-31	CARBON	100 5% 1/4W

Note: The components identified by shading and mark Δ are critical for safety. Replace only with part number specified.

Note: Les composants identifiés par un trame et une marque Δ sont critiques pour la sécurité. Ne les remplacer que par une pièce portant le numéro spécifié.



REF.NO.	PART NO.	DESCRIPTION	REMARK
R040	1-247-815-91	CARBON	220 5% 1/4W
R041	1-216-065-00	METAL GLAZE	4.7K 5% 1/10W
R042	1-216-065-00	METAL GLAZE	4.7K 5% 1/10W
R043	1-216-049-91	METAL GLAZE	1K 5% 1/10W
R045	1-247-815-91	CARBON	220 5% 1/4W
R044	1-216-049-91	METAL GLAZE	1K 5% 1/10W
R046	1-247-815-91	CARBON	220 5% 1/4W
R047	1-249-417-11	CARBON	1K 5% 1/4W
R048	1-249-417-11	CARBON	1K 5% 1/4W
R049	1-249-417-11	CARBON	1K 5% 1/4W
R050	1-247-815-91	CARBON	220 5% 1/4W
R051	1-247-815-91	CARBON	220 5% 1/4W
R052	1-216-061-00	METAL GLAZE	3.3K 5% 1/10W
R053	1-216-061-00	METAL GLAZE	3.3K 5% 1/10W
R054	1-216-061-00	METAL GLAZE	3.3K 5% 1/10W
R055	1-216-097-91	METAL GLAZE	100K 5% 1/10W
R056	1-216-033-00	METAL GLAZE	220 5% 1/10W
R057	1-249-417-11	CARBON	1K 5% 1/4W
R058	1-216-033-00	METAL GLAZE	220 5% 1/10W
R064	1-247-815-91	CARBON	220 5% 1/4W
R065	1-247-815-91	CARBON	220 5% 1/4W
R066	1-247-815-91	CARBON	220 5% 1/4W
R067	1-249-413-11	CARBON	470 5% 1/4W
R068	1-247-815-91	CARBON	220 5% 1/4W
R069	1-247-815-91	CARBON	220 5% 1/4W
R070	1-247-815-91	CARBON	220 5% 1/4W
R071	1-216-057-00	METAL GLAZE	2.2K 5% 1/10W
R072	1-216-033-00	METAL GLAZE	220 5% 1/10W
R073	1-216-033-00	METAL GLAZE	220 5% 1/10W
R074	1-216-033-00	METAL GLAZE	220 5% 1/10W
R075	1-216-033-00	METAL GLAZE	220 5% 1/10W
R076	1-216-033-00	METAL GLAZE	220 5% 1/10W
R077	1-216-033-00	METAL GLAZE	220 5% 1/10W
R078	1-249-417-11	CARBON	1K 5% 1/4W
R079	1-216-033-00	METAL GLAZE	220 5% 1/10W
R080	1-216-065-00	METAL GLAZE	4.7K 5% 1/10W
R081	1-216-025-91	METAL GLAZE	100 5% 1/10W
R082	1-216-025-91	METAL GLAZE	100 5% 1/10W
R083	1-249-429-11	CARBON	10K 5% 1/4W
R084	1-216-049-91	METAL GLAZE	1K 5% 1/10W
R087	1-247-815-91	CARBON	220 5% 1/4W
R090	1-216-033-00	METAL GLAZE	220 5% 1/10W
R092	1-249-429-11	CARBON	10K 5% 1/4W
R097	1-216-065-00	METAL GLAZE	4.7K 5% 1/10W
R099	1-216-065-00	METAL GLAZE	4.7K 5% 1/10W
R131	1-216-035-00	METAL GLAZE	270 5% 1/10W
R132	1-216-115-00	METAL GLAZE	560K 5% 1/10W
R133	1-216-039-00	METAL GLAZE	390 5% 1/10W
R135	1-216-073-00	METAL GLAZE	10K 5% 1/10W

REF.NO.	PART NO.	DESCRIPTION	REMARK
R136	1-216-073-00	METAL GLAZE	10K 5% 1/10W
R137	1-216-033-00	METAL GLAZE	220 5% 1/10W
R353	1-208-786-11	METAL GLAZE	1.5K 0.50% 1/10W
R354	1-216-077-00	METAL GLAZE	15K 5% 1/10W
R355	1-216-033-00	METAL GLAZE	220 5% 1/10W
R356	1-216-033-00	METAL GLAZE	220 5% 1/10W
R358	1-247-815-91	CARBON	220 5% 1/4W
R359	1-247-815-91	CARBON	220 5% 1/4W
R360	1-247-815-91	CARBON	220 5% 1/4W
R361	1-216-025-91	METAL GLAZE	100 5% 1/10W
R362	1-216-025-91	METAL GLAZE	100 5% 1/10W
R363	1-216-025-91	METAL GLAZE	100 5% 1/10W
R364	1-216-101-00	METAL GLAZE	150K 5% 1/10W
R365	1-216-101-00	METAL GLAZE	150K 5% 1/10W
R366	1-216-089-91	METAL GLAZE	47K 5% 1/10W
R367	1-216-097-91	METAL GLAZE	100K 5% 1/10W
R368	1-249-441-11	CARBON	100K 5% 1/4W
R369	1-216-097-91	METAL GLAZE	100K 5% 1/10W
R370	1-249-417-11	CARBON	1K 5% 1/4W
(KV-32V36/34V36C/35V36/37V36M/35V76)			
R371	1-216-053-00	METAL GLAZE	1.5K 5% 1/10W
(KV-32V36/34V36C/35V36/37V36M/35V76)			
R372	1-216-113-00	METAL GLAZE	470K 5% 1/10W
R373	1-216-073-00	METAL GLAZE	10K 5% 1/10W
R374	1-216-125-00	METAL GLAZE	1.5M 5% 1/10W
R375	1-216-025-91	METAL GLAZE	100 5% 1/10W
R376	1-216-073-00	METAL GLAZE	10K 5% 1/10W
R379	1-216-033-00	METAL GLAZE	220 5% 1/4W
R380	1-247-815-91	CARBON	220 5% 1/4W
R381	1-247-815-91	CARBON	220 5% 1/4W
R382	1-216-033-00	METAL GLAZE	220 5% 1/10W
R383	1-216-049-91	METAL GLAZE	1K 5% 1/10W
R384	1-216-109-00	METAL GLAZE	330K 5% 1/10W
R385	1-249-422-11	CARBON	2.7K 5% 1/4W
R386	1-216-049-91	METAL GLAZE	1K 5% 1/10W
R387	1-216-049-91	METAL GLAZE	1K 5% 1/10W
R388	1-216-089-91	METAL GLAZE	47K 5% 1/10W
R389	1-216-067-00	METAL GLAZE	5.6K 5% 1/10W
R390	1-216-035-00	METAL GLAZE	270 5% 1/10W
R391	1-208-810-11	METAL GLAZE	15K 0.50% 1/10W
R392	1-216-025-91	METAL GLAZE	100 5% 1/10W
R393	1-216-043-91	METAL GLAZE	560 5% 1/10W
R394	1-216-059-00	METAL GLAZE	2.7K 5% 1/10W
R395	1-216-061-00	METAL GLAZE	3.3K 5% 1/10W
R396	1-249-417-11	CARBON	1K 5% 1/4W
(KV-32V36/34V36C/35V36/37V36M/35V76)			
R397	1-249-425-11	CARBON	4.7K 5% 1/4W
R461	1-216-065-00	METAL GLAZE	4.7K 5% 1/10W
R462	1-216-089-91	METAL GLAZE	47K 5% 1/10W

A

Note:

The components identified by **A** in this manual have been carefully factory-selected for each set in order to satisfy regulations regarding X-ray radiation. Should replacement be required, replace only with the value originally used.

Note:

The components identified by shading and mark **Δ** are critical for safety. Replace only with part number specified.

REF.NO.	PART NO.	DESCRIPTION	REMARK
R463	1-249-435-11	CARBON	33K 5% 1/4W
R464	1-216-097-91	METAL GLAZE	100K 5% 1/10W
R465	1-249-413-11	CARBON	470 5% 1/4W
R466	1-249-382-11	CARBON	1.2 5% 1/4W F (KV-32V26/32V36/34V36C)
R467	1-216-069-00	METAL GLAZE	6.8K 5% 1/10W
R469	1-216-067-00	METAL GLAZE	5.6K 5% 1/10W (KV-32V36/34V36C/35V76)
R469	1-216-057-00	METAL GLAZE	2.2K 5% 1/10W (KV-35V36/37V36M)
R469	1-216-055-00	METAL GLAZE	1.8K 5% 1/10W (KV-32V26)
R470	1-216-077-00	METAL GLAZE	15K 5% 1/10W (KV-32V36/34V36C)
R471	1-216-069-00	METAL GLAZE	6.8K 5% 1/10W
R472	1-216-067-00	METAL GLAZE	5.6K 5% 1/10W (KV-32V36/34V36C/35V76)
R472	1-216-057-00	METAL GLAZE	2.2K 5% 1/10W (KV-35V36/37V36M)
R472	1-216-055-00	METAL GLAZE	1.8K 5% 1/10W (KV-32V26)
R473	1-249-398-11	CARBON	27 5% 1/4W
R474	1-216-077-00	METAL GLAZE	15K 5% 1/10W (KV-32V36/34V36C)
R475	1-249-430-11	CARBON	12K 5% 1/4W
R476	1-249-430-11	CARBON	12K 5% 1/4W
R477	1-249-398-11	CARBON	27 5% 1/4W
R478	1-249-418-11	CARBON	1.2K 5% 1/4W F
R479	1-249-418-11	CARBON	1.2K 5% 1/4W F
R480	1-249-385-11	CARBON	2.2 5% 1/4W F
R481	1-249-385-11	CARBON	2.2 5% 1/4W F
R482	1-249-421-11	CARBON	2.2 5% 1/4W F (KV-32V26/35V36/37V36M)
R483	1-249-421-11	CARBON	2.2 5% 1/4W F (KV-32V26/35V36/37V36M)
R501	1-216-037-00	METAL GLAZE	330 5% 1/10W
R502	1-216-061-00	METAL GLAZE	3.3K 5% 1/10W
R503	1-249-426-11	CARBON	5.6K 5% 1/4W F
R504 Δ	1-215-917-11	METAL OXIDE	1K 5% 3W F
R505	1-249-431-11	CARBON	15K 5% 1/4W
R506	1-215-861-00	METAL OXIDE	47 5% 1W F
R507	1-249-401-11	CARBON	47 5% 1/4W
R508	1-249-427-11	CARBON	6.8K 5% 1/4W
R509	1-247-750-11	CARBON	680 5% 1/2W F
R510 Δ	1-215-860-11	METAL OXIDE	33 5% 1W F
R511 Δ	1-215-886-11	METAL OXIDE	100 5% 2W F (KV-35V36/37V36M/35V76)
R511 Δ	1-215-885-00	METAL OXIDE	68 5% 2W F (KV-32V26/32V36/34V36C)
R512 Δ	1-215-886-11	METAL OXIDE	100 5% 2W F

REF.NO.	PART NO.	DESCRIPTION	REMARK
R515	1-216-083-00	METAL GLAZE	27K 5% 1/10W
R516	1-216-057-00	METAL GLAZE	2.2K 5% 1/10W
R517	1-249-415-11	CARBON	680 5% 1/4W
R518	1-216-073-00	METAL GLAZE	10K 5% 1/10W
R519	1-249-411-11	CARBON	330 5% 1/4W
R523	1-216-071-00	METAL GLAZE	8.2K 5% 1/10W (KV-35V36/37V36M/35V76)
R523	1-216-073-00	METAL GLAZE	10K 5% 1/10W (KV-32V26/32V36/34V36C)
R524	1-249-429-11	CARBON	10K 5% 1/4W
R525	1-216-071-00	METAL GLAZE	8.2K 5% 1/10W
R528	1-216-081-00	METAL GLAZE	22K 5% 1/10W
R529	1-208-812-11	METAL GLAZE	18K 0.50% 1/10W (KV-35V36/37V36M/35V76)
R529	1-208-814-11	METAL GLAZE	22K 0.50% 1/10W (KV-32V26/32V36/34V36C)
Δ R530 Δ		METAL GLAZE	1/10W
Δ R531 Δ		METAL GLAZE	1/10W (KV-35V36/37V36M/35V76)
Δ R531 Δ		METAL GLAZE	1/10W (KV-32V26/32V36/34V36C)
R532	1-208-760-11	METAL GLAZE	120 0.50% 1/10W
R533 Δ	1-215-878-00	METAL OXIDE	33K 5% 1W F (KV-35V36/37V36M/35V76)
R533 Δ	1-215-902-11	METAL OXIDE	47K 5% 1W F (KV-32V26/32V36/34V36C)
R535	1-216-101-00	METAL GLAZE	150K 5% 1/10W
R536 Δ	1-216-397-11	METAL OXIDE	4.7 5% 3W F (KV-35V36/37V36M/35V76)
R536 Δ	1-260-288-11	METAL OXIDE	4.7 5% 1/2W F (KV-32V26/32V36/34V36C)
R537 Δ	1-216-470-00	METAL OXIDE	18 5% 3W F (KV-35V36/37V36M/35V76)
R537 Δ	1-216-288-11	METAL OXIDE	47 5% 1/2W F (KV-32V26/32V36/34V36C)
R538	1-247-887-00	CARBON	220K 5% 1/4W
R541 Δ	1-249-377-11	CARBON	0.47 5% 1/4W F (KV-35V36/37V36M/35V76)
R542 Δ	1-249-397-11	CARBON	22 5% 1/4W F (KV-35V36/37V36M/35V76)
R543	1-249-377-11	CARBON	0.47 5% 1/4W F
R546	1-215-451-00	METAL	18K 1% 1/4W (KV-35V36/37V36M/35V76)
R546	1-215-453-00	METAL	22K 1% 1/4W (KV-32V26/32V36/34V36C)
R547	1-215-457-00	METAL	33K 1% 1/4W
R548 Δ	1-215-872-11	METAL OXIDE	3.3K 5% 1W F (KV-35V36/37V36M/35V76)
R549	1-215-437-00	METAL	4.7K 1% 1/4W
R550 Δ	1-249-377-11	CARBON	0.47 5% 1/4W F

Note: The components identified by shading and mark Δ are critical for safety. Replace only with part number specified.

Note: Les composants identifiés par un trame et une marque Δ sont critiques pour la sécurité. Ne les remplacer que par une pièce portant le numéro spécifié.



REF.NO.	PART NO.	DESCRIPTION	REMARK
R551 Δ	1-215-873-00	METAL OXIDE	4.7K 5% 1W F
R552	1-216-069-00	METAL GLAZE	6.8K 5% 1/10W
R553 Δ	1-249-377-11	CARBON	0.47 5% 1/4W F
R554	1-216-057-00	METAL GLAZE	2.2K 5% 1/10W
R561	1-216-073-00	METAL GLAZE	10K 5% 1/10W
R563 Δ	1-216-351-00	METAL OXIDE	1.5 5% 1W F
R564	1-249-393-11	CARBON	10 5% 1/4W
R565 Δ	1-215-890-11	METAL OXIDE	470 5% 2W F
R566	1-216-073-00	METAL GLAZE	10K 5% 1/10W
R567 Δ	1-249-385-11	CARBON	2.2 5% 1/4W F
R568	1-216-073-00	METAL GLAZE	10K 5% 1/10W
R569	1-216-073-00	METAL GLAZE	10K 5% 1/10W
R570	1-216-097-91	METAL GLAZE	100K 5% 1/10W
R571	1-216-081-00	METAL GLAZE	22K 5% 1/10W
R572	1-216-081-00	METAL GLAZE	22K 5% 1/10W
R573	1-216-097-91	METAL GLAZE	100K 5% 1/10W
R574 Δ	1-216-365-00	METAL OXIDE	0.47 5% 2W F
R575	1-216-113-00	METAL GLAZE	470K 5% 1/10W
R576	1-216-073-00	METAL GLAZE	10K 5% 1/10W
R577	1-216-097-91	METAL GLAZE	100K 5% 1/10W
R578	1-208-784-11	METAL GLAZE	1.2K 0.50% 1/10W
R579	1-208-842-11	METAL GLAZE	330K 0.50% 1/10W
R580	1-249-441-11	CARBON	100K 5% 1/4W
R1001	1-247-807-31	CARBON	100 5% 1/4W
R1002	1-247-807-31	CARBON	100 5% 1/4W
R1005	1-216-073-00	METAL GLAZE	10K 5% 1/10W
R1101	1-216-049-91	METAL GLAZE	1K 5% 1/10W
R1102	1-215-900-11	METAL OXIDE	22K 5% 2W F
R1103	1-216-051-00	METAL GLAZE	1.2K 5% 1/10W
R1104	1-216-083-00	METAL GLAZE	27K 5% 1/10W
R1105	1-216-689-11	METAL GLAZE	39K 5% 1/10W
R1106	1-216-049-91	METAL GLAZE	1K 5% 1/10W
R1107	1-216-065-00	METAL GLAZE	4.7K 5% 1/10W
R1108	1-216-073-00	METAL GLAZE	10K 5% 1/10W
R1109	1-216-019-00	METAL GLAZE	56 5% 1/10W
R1110	1-216-019-00	METAL GLAZE	56 5% 1/10W
R1111	1-216-019-00	METAL GLAZE	56 5% 1/10W
R1115	1-216-045-00	METAL GLAZE	680 5% 1/10W
R1117	1-249-425-11	CARBON	4.7K 5% 1/4W
R1118	1-249-425-11	CARBON	4.7K 5% 1/4W
R1120	1-216-057-00	METAL GLAZE	2.2K 5% 1/10W
R1121	1-216-035-00	METAL GLAZE	270 5% 1/10W
R1122	1-216-115-00	METAL GLAZE	560K 5% 1/10W
R1123	1-216-039-00	METAL GLAZE	390 5% 1/10W
R1125	1-216-057-00	METAL GLAZE	2.2K 5% 1/10W
R1126	1-216-035-00	METAL GLAZE	270 5% 1/10W
R1127	1-216-115-00	METAL GLAZE	560K 5% 1/10W
R1128	1-216-039-00	METAL GLAZE	390 5% 1/10W
R1130	1-216-057-00	METAL GLAZE	2.2K 5% 1/10W

REF.NO.	PART NO.	DESCRIPTION	REMARK
R1255	1-216-295-91	CONDUCTOR, CHIP (2012)	
R1258	1-216-061-00	METAL GLAZE	3.3K 5% 1/10W
R1259	1-216-097-91	METAL GLAZE	100K 5% 1/10W
R1260	1-216-061-00	METAL GLAZE	3.3K 5% 1/10W
R1294	1-216-049-91	METAL GLAZE	1K 5% 1/10W
R1295	1-216-049-91	METAL GLAZE	1K 5% 1/10W
R1351	1-247-815-91	CARBON	220 5% 1/4W
R1352	1-247-815-91	CARBON	220 5% 1/4W
R1353	1-247-815-91	CARBON	220 5% 1/4W
R1354	1-216-033-00	METAL GLAZE	220 5% 1/10W
R1355	1-216-025-91	METAL GLAZE	100 5% 1/10W
R1356	1-216-025-91	METAL GLAZE	100 5% 1/10W
R1357	1-216-025-91	METAL GLAZE	100 5% 1/10W
R1358	1-247-807-31	CARBON	100 5% 1/4W
R1359	1-216-025-91	METAL GLAZE	100 5% 1/10W
R1360	1-216-065-00	METAL GLAZE	4.7K 5% 1/10W
R1361	1-216-062-00	METAL GLAZE	3.6K 5% 1/10W
R1362	1-216-295-91	CONDUCTOR, CHIP (2012)	
R1407	1-216-073-00	METAL GLAZE	10K 5% 1/10W
R1408	1-249-429-11	CARBON	10K 5% 1/4W
R1409	1-249-429-11	CARBON	10K 5% 1/4W
R1411	1-216-073-00	METAL GLAZE	10K 5% 1/10W
R1412	1-216-093-00	METAL GLAZE	68K 5% 1/10W
R1413	1-216-089-91	METAL GLAZE	47K 5% 1/10W
R1414	1-216-089-91	METAL GLAZE	47K 5% 1/10W
R1415	1-216-025-91	METAL GLAZE	100 5% 1/10W
R1418	1-216-093-00	METAL GLAZE	68K 5% 1/10W
R1419	1-216-089-91	METAL GLAZE	47K 5% 1/10W
R1420	1-216-089-91	METAL GLAZE	47K 5% 1/10W
R1421	1-216-025-91	METAL GLAZE	100 5% 1/10W
R1424	1-247-807-31	CARBON	100 5% 1/4W
R1425	1-247-807-31	CARBON	100 5% 1/4W
SWITCH			
S501	1-572-707-11	SWITCH, LEVER	
TRANSFORMER			
T501	1-437-210-11	TRANSFORMER, HORIZONTAL DRIVE	
T502 Δ	1-429-408-11	TRANSFORMER, FERRITE (PMT)	500uH (KV-35V36/37V36M/35V76)
T502 Δ	1-429-545-11	TRANSFORMER, FERRITE (PMT)	400uH (KV-32V26/32V36/34V76C)
T503 Δ	1-439-520-11	TRANSFORMER ASSY, FLYBACK (NX-3001)	(KV-35V36/37V36M/35V76)
T503 Δ	1-439-207-11	TRANSFORMER ASSY, FLYBACK (NX-A2609)	(KV-32V26/32V36/34V76C)
T504	1-413-059-00	TRANSFORMER, FERRITE (DFT)	(KV-35V36/37V36M/35V76)



Note: The components identified by shading and mark Δ are critical for safety. Replace only with part number specified.

Note: Les composants identifiés par un trame et une marque Δ sont critiques pour la sécurité. Ne les remplacer que par une pièce portant le numéro spécifié.

REF.NO.	PART NO.	DESCRIPTION	REMARK
CRYSTAL			
X001	1-578-774-11	VIBRATOR, CRYSTAL	
X353	1-567-505-11	OSCILLATOR, CRYSTAL	
X354	1-577-611-11	OSCILLATOR, CERAMIC	
TUNER			
TU102 Δ	8-598-340-00	TUNER BTF-WA404	
G			
* A-1316-252-A	G BOARD, COMPLETE (KV-34V36C)		
* A-1316-261-A	G BOARD, COMPLETE (KV-32V26/32V36)		
* A-1316-262-A	G BOARD, COMPLETE (KV-35V36C/35V76/37V36M)		
4-382-854-11	SCREW (M3X10), P, SW (+)		
CAPACITOR			
C601	1-130-711-00	FILM	0.22MF 20% 250V (KV-35V36/35V76/37V36M)
C602	1-126-963-11	ELECT	4.7MF 20% 50V (KV-34V36C)
C603 Δ	1-113-915-11	CERAMIC	0.001MF 20% 250V
C604 Δ	1-136-346-21	FILM	0.22MF 20% 125V (KV32V26/32V36/35V36/35V76/37V36M)
C605 Δ	1-136-346-51	FILM	0.22MF 20% 125V (KV32V26/32V36/35V36/35V76/37V36M)
C605 Δ	1-136-346-61	FILM	0.22MF 20% 300V (KV-34V36C)
C606 Δ	1-115-388-11	ELECT	560MF 20% 200V
C607 Δ	1-115-388-11	ELECT	560MF 20% 200V
C608	1-164-625-11	CERAMIC	680PF 10% 500V (KV-32V26/32V36/35V36/35V76/37V36M)
C608	1-164-645-11	CERAMIC	1000PF 10% 500V (KV-34V36C)
C609	1-136-173-00	FILM	0.47MF 5% 50V
C610	1-136-173-00	FILM	0.47MF 5% 50V
C611	1-136-169-00	FILM	0.22MF 5% 50V
C612	1-136-169-00	FILM	0.22MF 5% 50V
C613	1-164-645-11	CERAMIC	1000PF 10% 500V
C614	1-164-645-11	CERAMIC	1000PF 10% 500V
C615	1-136-759-11	FILM	0.039MF 5% 630V
C617 Δ	1-113-915-11	CERAMIC	0.001MF 20% 250V
C626 Δ	1-113-897-11	CERAMIC	100PF 10% 250V (KV-34V36C)
C641	1-126-943-11	ELECT	2200MF 20% 25V
C642	1-126-767-11	ELECT	1000MF 20% 16V
C643	1-107-641-11	ELECT	220MF 20% 160V
C646	1-126-933-11	ELECT	100MF 20% 16V
C647	1-128-551-11	ELECT	22MF 20% 25V

REF.NO.	PART NO.	DESCRIPTION	REMARK
C648	1-126-933-11	ELECT	100MF 20% 16V
C651	1-137-366-11	FILM	0.0022MF 5% 50V
C652	1-106-351-00	MYLAR	0.0022MF 99% 200V
C653	1-107-636-11	ELECT	10MF 20% 160V
C654	1-164-625-11	CERAMIC	680PF 10% 500V
C655	1-164-625-11	CERAMIC	680PF 10% 500V
C656	1-164-625-11	CERAMIC	680PF 10% 500V
C657	1-164-625-11	CERAMIC	680PF 10% 500V
C661	1-126-963-11	ELECT	4.7MF 20% 50V (KV-32V26/32V36/35V36/35V76/37V36M)
C690	1-164-645-11	CERAMIC	1000PF 10% 500V
C691	1-164-645-11	CERAMIC	1000PF 10% 500V
CONNECTOR			
CN601	* 1-573-963-11	PIN, CONNECTOR (PC BOARD) 3P (KV-35V36/35V76/37V36M)	
CN601	* 1-508-765-21	PIN, CONNECTOR (5MM PITCH) 3P (KV-32V26/32V36/34V36C)	
CN602	* 1-580-844-11	PIN, CONNECTOR (POWER) 2P	
CN603	* 1-573-963-11	PIN, CONNECTOR (PC BOARD) 3P (KV-35V36/35V76/37V36M)	
CN641	* 1-564-515-11	PLUG, CONNECTOR 12P	
DIODE			
D601	8-719-911-19	DIODE 1SS119-25	
D602 Δ	8-719-510-53	DIODE D4SB60L	
D603	8-719-911-19	DIODE 1SS119-25	
D604	8-719-911-19	DIODE 1SS119-25	
D605	8-719-911-19	DIODE 1SS119-25	
D606	8-719-911-19	DIODE 1SS119-25	
D607	8-719-911-19	DIODE 1SS119-25	
D608	8-719-911-19	DIODE 1SS119-25	
D609	8-719-911-19	DIODE 1SS119-25	
D610	8-719-911-19	DIODE 1SS119-25	
D615	8-719-028-45	DIODE D2L20U	
D641	8-719-052-40	DIODE RBA-1004B	
D643	8-719-028-45	DIODE D2L20U	
D644	8-719-028-45	DIODE D2L20U	
D645	8-719-028-45	DIODE D2L20U	
D646	8-719-510-12	DIODE D10SC4M	
D648	8-719-057-52	DIODE EZ0150AV1	
D649	8-719-510-02	DIODE D1NS4	
D650	8-719-510-02	DIODE D1NS4	
FUSE			
F601 Δ	1-533-223-11	HOLDER, FUSE	
F601 Δ	1-576-193-11	FUSE 6.3A/125V (KV-32V26/32V36/35V36/35V76/37V36M)	
F601 Δ	1-532-506-51	FUSE 6.3A/250V (KV-34V36C)	



Note: The components identified by shading and mark Δ are critical for safety. Replace only with part number specified.

Note: Les composants identifiés par un trame et une marque Δ sont critiques pour la sécurité. Ne les remplacer que par une pièce portant le numéro spécifié.

REF.NO.	PART NO.	DESCRIPTION	REMARK
FERRITE BEAD			
FB601	1-410-397-21	FERRITE BEAD INDUCTOR	1.1UH
FB602	1-410-397-21	FERRITE BEAD INDUCTOR	1.1UH
FB641	1-410-397-21	FERRITE BEAD INDUCTOR	1.1UH
FB642	1-410-397-21	FERRITE BEAD INDUCTOR	1.1UH
FB643	1-410-397-21	FERRITE BEAD INDUCTOR	1.1UH
FB644	1-410-397-21	FERRITE BEAD INDUCTOR	1.1UH
FB645	1-410-397-21	FERRITE BEAD INDUCTOR	1.1UH
FB646	1-410-397-21	FERRITE BEAD INDUCTOR	1.1UH
FB647	1-410-397-21	FERRITE BEAD INDUCTOR	1.1UH
FB648	1-410-397-21	FERRITE BEAD INDUCTOR	1.1UH
IC			
IC641	8-749-920-58	IC SI-3090CA	
IC642	8-759-701-56	IC NJM78M05FA	
IC643	8-749-012-13	IC DM-58	
COIL			
L642	1-412-529-11	INDUCTOR	22UH
L643	1-412-525-31	INDUCTOR	10UH
TRANSISTOR			
Q601 Δ	8-729-019-49	TRANSISTOR 2SC4834MNP	
Q602 Δ	8-729-019-49	TRANSISTOR 2SC4834MNP	
Q644	8-729-119-78	TRANSISTOR 2SC2785-HFE	
Q645	8-729-119-76	TRANSISTOR 2SA1175-HFE	
Q646	8-729-119-78	TRANSISTOR 2SC3311A	
		(KV-32V26/32V36/35V36/35V76/37V36M)	
RESISTOR			
R603 Δ	1-219-776-11	CARBON	2.2M 10% 1/2W
		(KV-32V26/32V36/35V36/35V76/37V36M)	
R603 Δ	1-247-289-00	CARBON	8.2M 5% 1W
		(KV-34V36C)	
R605	1-247-893-11	CARBON	390K 5% 1/4W
R606	1-247-893-11	CARBON	390K 5% 1/4W
R607 Δ	1-202-933-61	FUSIBLE	0.1 10% 1/2W F
R608 Δ	1-216-372-11	METAL OXIDE	1.8 5% 2W F
		(KV-32V26/32V36/35V36/35V76/37V36M)	
R608 Δ	1-216-369-00	METAL OXIDE	1 5% 2W F
		(KV-34V36C)	
R609	1-247-791-91	CARBON	22 5% 1/4W
R610	1-247-791-91	CARBON	22 5% 1/4W
R611 Δ	1-216-372-11	METAL OXIDE	1.8 5% 2W F
		(KV-32V26/32V36/35V36/35V76/37V36M)	
R611 Δ	1-216-369-00	METAL OXIDE	1 5% 2W F
		(KV-34V36C)	
R612	1-247-887-00	CARBON	220K 5% 1/4W
R613	1-247-887-00	CARBON	220K 5% 1/4W

REF.NO.	PART NO.	DESCRIPTION	REMARK
R614	1-247-887-00	CARBON	220K 5% 1/4W
R615	1-247-887-00	CARBON	220K 5% 1/4W
R616	1-247-791-91	CARBON	22 5% 1/4W
R617	1-247-791-91	CARBON	22 5% 1/4W
R622	1-212-958-00	FUSIBLE	10 5% 1/2W F
R623 Δ	1-243-032-11	WIREWOUND	1 5% 20W
		(KV-32V26/32V36/35V36/35V76/37V36M)	
R623 Δ	1-205-943-11	WIREWOUND	3.9 5% 20W
		(KV-34V36C)	
R641	1-247-843-11	CARBON	3.3K 5% 1/4W
R642	1-247-843-11	CARBON	3.3K 5% 1/4W
R643	1-249-387-11	CARBON	3.3 5% 1/4W F
R644 Δ	1-215-882-00	METAL OXIDE	22 5% 2W F
R645 Δ	1-260-304-51	CARBON	10 5% 1/2W
		(KV-34V36C)	
R647	1-249-417-11	CARBON	1K 5% 1/4W
R648	1-247-887-00	CARBON	220K 5% 1/4W
R649	1-249-425-11	CARBON	4.7K 5% 1/4W F
R652	1-249-421-11	CARBON	2.2K 5% 1/4W
R659	1-249-429-11	CARBON	10K 5% 1/4W
		(KV-34V36C)	
R661	1-249-413-11	CARBON	470 5% 1/4W F
R662	1-249-429-11	CARBON	10K 5% 1/4W
R663 Δ	1-249-377-11	CARBON	0.47 5% 1/4W F
R664 Δ	1-249-377-11	CARBON	0.47 5% 1/4W F
R665 Δ	1-249-377-11	CARBON	0.47 5% 1/4W F
R666 Δ	1-249-377-11	CARBON	0.47 5% 1/4W F
R667 Δ	1-249-377-11	CARBON	0.47 5% 1/4W F
R668 Δ	1-249-377-11	CARBON	0.47 5% 1/4W F
R670 Δ	1-249-377-11	CARBON	0.47 5% 1/4W F
R671 Δ	1-249-377-11	CARBON	0.47 5% 1/4W F
R672 Δ	1-249-377-11	CARBON	0.47 5% 1/4W F
R678	1-247-863-91	CARBON	22K 5% 1/4W
		(KV-32V26/32V36/35V36/35V76/37V36M)	
R679	1-247-863-91	CARBON	22K 5% 1/4W
		(KV-32V26/32V36/35V36/35V76/37V36M)	
R680	1-249-429-11	CARBON	10K 5% 1/4W
		(KV-32V26/32V36/35V36/35V76/37V36M)	
R681	1-249-407-11	CARBON	150 5% 1/4W
		(KV-32V26/32V36/35V36/35V76/37V36M)	
RELAY			
RY601 Δ	1-755-146-11	RELAY (KV-32V26/32V36/35V36/35V76/37V36M)	
RY601 Δ	1-755-018-11	RELAY (KV-34V36C)	
TRANSFORMER			
T601 Δ	1-426-717-11	TRANSFORMER, LINE FILTER (LFT)	
		(KV-32V26/32V36/35V36/35V76/37V36M)	
T602 Δ	1-424-220-11	TRANSFORMER, LINE FILTER	
		(KV-32V26/32V36/35V36/35V76/37V36M)	



Note: The components identified by shading and mark Δ are critical for safety. Replace only with part number specified.

Note: Les composants identifiés par un trame et une marque Δ sont critiques pour la sécurité. Ne les remplacer que par une pièce portant le numéro spécifié.

REF.NO.	PART NO.	DESCRIPTION	REMARK
T602	Δ 1-426-717-11	TRANSFORMER, LINE FILTER (KV-34V36C)	
T603	Δ 1-427-864-11	TRANSFORMER, CONVERTER (PRT)	
T605	1-429-415-11	TRANSFORMER, CONVERTER (PIT)	

THERMISTOR

THP601	Δ 1-809-539-11	THERMISTOR, POSITIVE (KV-32V26/32V36/35V36/35V76/37V36M)	
THP601	Δ 1-809-827-11	THERMISTOR, POSITIVE (KV-34V36C)	

VARISTOR

VDR601	1-810-974-21	VARISTOR	
--------	--------------	----------	--



* A-1331-522-A C BOARD, MOUNTED (KV-35V36/35V76/37V36M)
* A-1331-549-A C BOARD MOUNTED (KV-32V26/32V36/34V36C)

4-382-854-11 SCREW (M3X10), P, SW (+)

CAPACITOR

C1765	1-102-116-00	CERAMIC	680PF	10%	50V
C1766	1-102-117-00	CERAMIC	820PF	10%	50V
C1767	1-102-116-00	CERAMIC	680PF	10%	50V
C1775	1-102-116-00	CERAMIC	680PF	10%	50V
C1776	1-102-117-00	CERAMIC	820PF	10%	50V
C1777	1-102-116-00	CERAMIC	680PF	10%	50V
C1785	1-102-116-00	CERAMIC	680PF	10%	50V
C1786	1-102-117-00	CERAMIC	820PF	10%	50V
C1787	1-102-116-00	CERAMIC	680PF	10%	50V
C1790	1-102-129-00	CERAMIC	0.01MF	10%	50V
C1791	1-126-933-11	ELECT	100MF	20%	16V
C1793	1-107-651-11	ELECT	4.7MF	20%	250V
C1795	1-102-074-00	CERAMIC	0.001MF	10%	50V
C1797	1-106-375-12	MYLAR	0.022MF	99%	200V
C1798	1-106-375-12	MYLAR	0.022MF	99%	200V
C1799	1-162-114-00	CERAMIC	0.0047MF		2KV

CONNECTOR

CN1761*	1-564-509-11	PLUG, CONNECTOR 6P	
CN1762*	1-508-784-00	PIN, CONNECTOR (5MM PITCH) 1P (KV-35V36/35V76/37V36M)	
CN1764*	1-564-507-11	PLUG, CONNECTOR 4P	
CN1765	1-695-915-11	TAB (CONTACT) (KV-32V26/32V36/34V36C)	
CN1766	1-695-915-11	TAB (CONTACT) 1P	

DIODE

D1761	8-719-991-33	DIODE 1SS133T-77	
D1762	8-719-991-33	DIODE 1SS133T-77	
D1763	8-719-991-33	DIODE 1SS133T-77	

REF.NO.	PART NO.	DESCRIPTION	REMARK
D1771	8-719-991-33	DIODE 1SS133T-77	
D1772	8-719-991-33	DIODE 1SS133T-77	
D1773	8-719-991-33	DIODE 1SS133T-77	
D1781	8-719-991-33	DIODE 1SS133T-77	
D1782	8-719-991-33	DIODE 1SS133T-77	

D1783	8-719-991-33	DIODE 1SS133T-77	
D1790	8-719-991-33	DIODE 1SS133T-77	
D1792	8-719-983-14	DIODE MTZJ-T-77-3.9	

JACK

J1761	Δ 1-251-328-11	SOCKET, CRT	
-------	-----------------------	-------------	--

COIL

L1790	1-410-667-31	INDUCTOR	22UH
-------	--------------	----------	------

TRANSISTOR

Q1761	8-729-119-78	TRANSISTOR 2SC2785-HFE	
Q1762	8-729-326-11	TRANSISTOR 2SC2611	
Q1763	8-729-200-17	TRANSISTOR 2SA1091-0	
Q1771	8-729-119-78	TRANSISTOR 2SC2785-HFE	
Q1772	8-729-326-11	TRANSISTOR 2SC2611	
Q1773	8-729-200-17	TRANSISTOR 2SA1091-0	
Q1781	8-729-119-78	TRANSISTOR 2SC2785-HFE	
Q1782	8-729-326-11	TRANSISTOR 2SC2611	
Q1783	8-729-200-17	TRANSISTOR 2SA1091-0	
Q1790	8-729-119-76	TRANSISTOR 2SA1175-HFE	

RESISTOR

R1760	1-260-105-11	CARBON	3.3K	5%	1/2W
R1761	1-247-807-31	CARBON	100	5%	1/4W
R1763	1-249-409-11	CARBON	220	5%	1/4W F
R1764	Δ 1-216-486-00	METAL OXIDE	8.2K	5%	3W F
R1765	1-249-411-11	CARBON	330	5%	1/4W
R1766	1-249-393-11	CARBON	10	5%	1/4W
R1767	1-249-429-11	CARBON	10K	5%	1/4W
R1768	1-249-411-11	CARBON	330	5%	1/4W
R1770	1-260-105-11	CARBON	3.3K	5%	1/2W
R1771	1-247-807-31	CARBON	100	5%	1/4W
R1773	1-249-409-11	CARBON	220	5%	1/4W F
R1774	Δ 1-216-486-00	METAL OXIDE	8.2K	5%	3W F
R1775	1-249-407-11	CARBON	150	5%	1/4W
R1776	1-249-393-11	CARBON	10	5%	1/4W
R1777	1-249-429-11	CARBON	10K	5%	1/4W
R1780	1-260-105-11	CARBON	3.3K	5%	1/2W
R1781	1-247-807-31	CARBON	100	5%	1/4W
R1783	1-249-409-11	CARBON	220	5%	1/4W F
R1784	Δ 1-216-486-00	METAL OXIDE	8.2K	5%	3W F
R1785	1-249-407-11	CARBON	150	5%	1/4W

Note: The components identified by shading and mark Δ are critical for safety. Replace only with part number specified.

Note: Les composants identifiés par un trame et une marque Δ sont critiques pour la sécurité. Ne les remplacer que par une pièce portant le numéro spécifié.



REF.NO.	PART NO.	DESCRIPTION	REMARK
R1786	1-249-393-11	CARBON	10 5% 1/4W
R1787	1-249-429-11	CARBON	10K 5% 1/4W
R1789	1-249-437-11	CARBON	47K 5% 1/4W
R1792	1-247-815-91	CARBON	220 5% 1/4W
R1793	1-247-863-91	CARBON	22K 5% 1/4W
R1794	1-249-417-11	CARBON	1K 5% 1/4W
R1795	1-260-087-11	CARBON	100 5% 1/2W
R1796 Δ	1-216-365-00	METAL OXIDE	0.47 5% 2W F (KV-35V36/35V76/37V36M)
R1796 Δ	1-216-374-00	METAL OXIDE	2.7 5% 2W F (KV-32V26/32V36/34V36C)
R1797	1-260-123-11	CARBON	100K 5% 1/2W
R1798	1-260-133-11	CARBON	680K 5% 1/2W (KV-35V36/35V76/37V36M)
R1799	1-260-123-11	CARBON	100K 5% 1/2W (KV-35V36/35V76/37V36M)

VARIABLE RESISTOR

RV1791 1-230-641-11 RES, ADJ, METAL GLAZE 2.2M
(KV-35V36/35V76/37V36M)

WA

*A-1372-211-A WA BOARD, MOUNTED (KV-35V36/35V76/37V36M)
4-382-854-11 SCREW (M3X10), P, SW (+)

CAPACITOR

C941	1-126-935-11	ELECT	470MF 20% 16V
C944	1-164-232-11	CERAMIC CHIP	0.01MF 10% 50V
C945	1-163-001-11	CERAMIC CHIP	220PF 10% 50V
C946	1-126-933-11	ELECT	100MF 20% 16V
C949	1-161-830-00	CERAMIC	0.0047MF 500V
C950	1-126-933-11	ELECT	100MF 20% 16V
C951	1-107-638-11	ELECT	33MF 20% 160V
C952	1-104-999-11	MYLAR	0.1MF 10% 200V
C953	1-106-383-00	MYLAR	0.047MF 10% 200V
C954	1-137-364-11	FILM	0.001MF 5% 50V
C955	1-107-667-11	ELECT	2.2MF 20% 160V
C956	1-137-364-11	FILM	0.001MF 5% 50V
C957	1-106-383-00	MYLAR	0.047MF 10% 200V
C958	1-126-933-11	ELECT	100MF 20% 16V
C961	1-163-251-11	CERAMIC CHIP	100PF 5% 50V
C962	1-164-232-11	CERAMIC CHIP	0.01MF 10% 50V
C965	1-163-035-00	CERAMIC CHIP	0.047MF 50V
C966	1-163-009-11	CERAMIC CHIP	0.001MF 10% 50V
C967	1-129-718-00	FILM	0.022MF 5% 630V
C968	1-137-579-11	FILM	0.068MF 5% 100V
C969	1-163-035-00	CERAMIC CHIP	0.047MF 50V

REF.NO.	PART NO.	DESCRIPTION	REMARK
C981	1-126-941-11	ELECT	470MF 20% 25V
C983	1-137-366-11	FILM	0.0022MF 5% 50V

CONNECTOR

CN941 1-564-511-11 PLUG, CONNECTOR 8P
CN961 * 1-770-723-11 CONNECTOR, BOARD TO BOARD 8P
CN981 * 1-564-506-11 PLUG, CONNECTOR 3P

DIODE

D941 8-719-991-33 DIODE 1SS133T-77
D946 8-719-110-88 DIODE RD39ESB2
D947 8-719-110-88 DIODE RD39ESB2
D961 8-719-109-89 DIODE RD5.6ESB2
D962 8-719-991-33 DIODE 1SS133T-77

D964 8-719-302-43 DIODE EL1Z

IC

IC961 8-759-700-07 IC NJM2903M
IC981 8-759-603-37 IC M5216P

COIL

L942 1-215-863-11 METAL OXIDE 100 5% 1W F
L962 1-406-989-21 COIL, CHOKE 10MMH
L963 1-406-675-11 COIL, CHOKE 4.7MMH

TRANSISTOR

Q943 8-729-422-27 TRANSISTOR 2SD601A-Q
Q944 8-729-422-27 TRANSISTOR 2SD601A-Q
Q945 8-729-422-27 TRANSISTOR 2SD601A-Q
Q946 8-729-017-05 TRANSISTOR 2SA1837
Q947 8-729-017-06 TRANSISTOR 2SC4793

Q962 8-729-931-45 TRANSISTOR IRF614
Q963 8-729-216-22 TRANSISTOR 2SA1162-G
Q965 8-729-422-27 TRANSISTOR 2SD601A-Q
Q966 8-729-216-22 TRANSISTOR 2SA1162-G
Q981 8-729-422-27 TRANSISTOR 2SD601A-Q

RESISTOR

R943 1-216-025-91 METAL GLAZE 100 5% 1/10W
R948 1-216-049-91 METAL GLAZE 1K 5% 1/10W
R949 1-216-049-91 METAL GLAZE 1K 5% 1/10W
R950 1-216-049-91 METAL GLAZE 1K 5% 1/10W
R951 1-216-049-91 METAL GLAZE 1K 5% 1/10W
R952 1-216-037-00 METAL GLAZE 330 5% 1/10W
R953 1-216-021-00 METAL GLAZE 68 5% 1/10W
R954 1-216-033-00 METAL GLAZE 220 5% 1/10W
R955 1-216-047-91 METAL GLAZE 820 5% 1/10W
R956 1-216-295-91 CONDUCTOR, CHIP (2012)

WA WB

Note: The components identified by shading and mark Δ are critical for safety. Replace only with part number specified.

Note: Les composants identifiés par un trame et une marque Δ sont critiques pour la sécurité. Ne les remplacer que par une pièce portant le numéro spécifié.

REF.NO.	PART NO.	DESCRIPTION	REMARK
R957	1-216-073-00	METAL GLAZE	10K 5% 1/10W
R958	1-216-295-91	CONDUCTOR, CHIP	(2012)
R959	1-216-021-00	METAL GLAZE	68 5% 1/10W
R960	1-216-689-11	METAL GLAZE	39K 5% 1/10W
R961	1-216-073-00	METAL GLAZE	10K 5% 1/10W
R962	1-216-057-00	METAL GLAZE	2.2K 5% 1/10W
R963	1-216-097-91	METAL GLAZE	100K 5% 1/10W
R964	1-216-073-00	METAL GLAZE	10K 5% 1/10W
R965	1-216-073-00	METAL GLAZE	10K 5% 1/10W
R966	1-216-097-91	METAL GLAZE	100K 5% 1/10W
R967	1-216-065-00	METAL GLAZE	4.7K 5% 1/10W
R968	1-216-083-00	METAL GLAZE	27K 5% 1/10W
R969	1-216-295-91	CONDUCTOR, CHIP	(2012)
R970	1-216-033-00	METAL GLAZE	220 5% 1/10W
R971	1-247-899-11	CARBON	680K 5% 1/4W
R972	1-216-073-00	METAL GLAZE	10K 5% 1/10W
R973	1-216-121-91	METAL GLAZE	1M 5% 1/10W
R974	1-216-073-00	METAL GLAZE	10K 5% 1/10W
R975 Δ	1-216-446-00	METAL OXIDE	18 5% 2W F
R976 Δ	1-216-423-11	METAL OXIDE	27 5% 1W F
R979	1-216-017-91	METAL GLAZE	47 5% 1/10W
R981	1-216-081-00	METAL GLAZE	22K 5% 1/10W
R982	1-216-081-00	METAL GLAZE	22K 5% 1/10W
R983	1-216-081-00	METAL GLAZE	22K 5% 1/10W
R984	1-216-081-00	METAL GLAZE	22K 5% 1/10W
R987	1-216-049-91	METAL GLAZE	1K 5% 1/10W
R988	1-216-295-91	CONDUCTOR, CHIP	(2012)
R989	1-216-304-11	METAL GLAZE	3.3 5% 1/10W
R992	1-216-073-00	METAL GLAZE	10K 5% 1/10W
R1941	1-260-311-11	CARBON	39 5% 1/2W
R1942	1-249-384-11	CARBON	1.8 5% 1/4W F
R1943	1-249-414-11	CARBON	560 5% 1/4W F
R1944	1-249-432-11	CARBON	18K 5% 1/4W
R1945	1-216-476-11	METAL OXIDE	180 5% 3W F
R1946	1-249-417-11	CARBON	1K 5% 1/4W F
R1947	1-249-432-11	CARBON	18K 5% 1/4W
R1948	1-249-414-11	CARBON	560 5% 1/4W
R1949	1-249-384-11	CARBON	1.8 5% 1/4W F
R1950	1-249-400-11	CARBON	39 5% 1/4W F

WB

* A-1372-225-A MOUNTED PCB, WB (KV-32V36/34V36C)

4-382-854-11 SCREW (M3X10), P, SW (+)

CAPACITOR

C2941	1-126-935-11	ELECT	470MF	20%	16V
C2944	1-164-232-11	CERAMIC CHIP	0.01MF	10%	50V

REF.NO.	PART NO.	DESCRIPTION	REMARK
C2946	1-126-933-11	ELECT	100MF 20% 16V
C2949	1-161-830-00	CERAMIC	0.0047MF 500V
C2950	1-126-933-11	ELECT	100MF 20% 16V
C2951	1-107-638-11	ELECT	33MF 20% 160V
C2952	1-104-999-11	MYLAR	0.1MF 10% 200V
C2953	1-106-383-00	MYLAR	0.047MF 10% 200V
C2954	1-137-364-11	FILM	0.001MF 5% 50V
C2955	1-107-667-11	ELECT	2.2MF 20% 160V
C2956	1-137-364-11	FILM	0.001MF 5% 50V
C2957	1-106-383-00	MYLAR	0.047MF 10% 200V
C2958	1-126-933-11	ELECT	100MF 20% 16V
C2975	1-163-001-11	CERAMIC CHIP	220PF 10% 50V

CONNECTOR

CN2941 *1-564-508-11 PLUG, CONNECTOR 5P

DIODE

D2941	8-719-991-33	DIODE 1SS133T-77
D2946	8-719-110-88	DIODE RD39ESB2
D2947	8-719-110-88	DIODE RD39ESB2

COIL

L2942 1-215-863-11 METAL OXIDE 100 5% 1W F

TRANSISTOR

Q2943	8-729-422-27	TRANSISTOR 2SD601A-Q
Q2944	8-729-422-27	TRANSISTOR 2SD601A-Q
Q2945	8-729-422-27	TRANSISTOR 2SD601A-Q
Q2946	8-729-017-05	TRANSISTOR 2SA1837
Q2947	8-729-017-06	TRANSISTOR 2SC4793

Q2965	8-729-422-27	TRANSISTOR 2SD601A-Q
Q2966	8-729-216-22	TRANSISTOR 2SA1162-G

RESISTOR

R2943	1-216-025-91	METAL GLAZE	100	5%	1/10W
R2948	1-216-049-91	METAL GLAZE	1K	5%	1/10W
R2949	1-216-049-91	METAL GLAZE	1K	5%	1/10W
R2950	1-216-049-91	METAL GLAZE	1K	5%	1/10W
R2951	1-216-049-91	METAL GLAZE	1K	5%	1/10W

R2952	1-216-037-00	METAL GLAZE	330	5%	1/10W
R2953	1-216-021-00	METAL GLAZE	68	5%	1/10W
R2954	1-216-033-00	METAL GLAZE	220	5%	1/10W
R2955	1-216-047-91	METAL GLAZE	820	5%	1/10W
R2956	1-216-295-91	CONDUCTOR, CHIP	(2012)		

R2957	1-216-073-00	METAL GLAZE	10K	5%	1/10W
R2958	1-216-295-91	CONDUCTOR, CHIP	(2012)		
R2959	1-216-021-00	METAL GLAZE	68	5%	1/10W
R2979	1-216-017-91	METAL GLAZE	47	5%	1/10W

Note: The components identified by shading and mark Δ are critical for safety. Replace only with part number specified.

Note: Les composants identifiés par un trame et une marque Δ sont critiques pour la sécurité. Ne les remplacer que par une pièce portant le numéro spécifié.

HS HV

REF.NO.	PART NO.	DESCRIPTION	REMARK
R4941	1-260-311-11	CARBON	39 5% 1/2W
R4942	1-249-384-11	CARBON	1.8 5% 1/4W F
R4943	1-249-414-11	CARBON	560 5% 1/4W F
R4944	1-249-432-11	CARBON	18K 5% 1/4W
R4945	1-216-476-11	METAL OXIDE	180 5% 3W F
R4946	1-249-417-11	CARBON	1K 5% 1/4W F
R4947	1-249-432-11	CARBON	18K 5% 1/4W
R4948	1-249-414-11	CARBON	560 5% 1/4W
R4949	1-249-384-11	CARBON	1.8 5% 1/4W F
R4950	1-249-400-11	CARBON	39 5% 1/4W F

HS

* A-1372-326-A HS BOARD, MOUNTED (EXCEPT KV-37V36M)

CAPACITOR

C2168	1-104-665-11	ELECT	100MF	20%	25V
C2169	1-126-959-11	ELECT	0.47MF	20%	50V

CONNECTOR

CN2101	1-564-524-11	PLUG, CONNECTOR 9P
CN2102	1-564-523-11	PLUG, CONNECTOR 8P

HV

* A-1372-330-A HV BOARD, MOUNTED (EXCEPT KV-32V26)

* A-1372-325-A HV BOARD, MOUNTED (KV-32V26)

CAPACITOR

C2068	1-104-665-11	ELECT	100MF	20%	25V
C2070	1-165-319-11	CERAMIC CHIP	0.1MF	50V	
C2231	1-163-031-11	CERAMIC CHIP	0.01MF	50V	
C2232	1-136-161-00	FILM	0.047MF	5%	50V
C2233	1-136-161-00	FILM	0.047MF	5%	50V
C2234	1-126-960-11	ELECT	1MF	20%	50V
C2235	1-126-960-11	ELECT	1MF	20%	50V
C2236	1-126-933-11	ELECT	100MF	20%	16V

CONNECTOR

CN2002	*1-564-518-11	PLUG, CONNECTOR 3P
		(KV-32V36/34V36C/35V36/35V76/37V36M)

DIODE

D2006	1-810-039-11	LED UNIT
D2231	8-719-110-17	DIODE RD10ESB2
		(KV-32V36/34V36C/35V36/35V76/37V36M)

REF.NO.	PART NO.	DESCRIPTION	REMARK
D2232	8-719-110-17	DIODE RD10ESB2	
		(KV-32V36/34V36C/35V36/35V76/37V36M)	
D2233	8-719-110-17	DIODE RD10ESB2	
		(KV-32V36/34V36C/35V36/35V76/37V36M)	
D2236	8-719-110-17	DIODE RD10ESB2	

IC

IC2003	8-742-014-10	HIC SBX1981-51
IC2004	8-749-012-12	IC IS474

JACK

J2231	1-691-110-11	JACK, PIN 3P
J2232	1-694-063-11	TERMINAL, S
		(KV-32V36/34V36C/35V36/35V76/37V36M)

TRANSISTOR

Q2008	8-729-216-22	TRANSISTOR 2SA1162-G
Q2009	8-729-422-27	TRANSISTOR 2SD601A-Q

RESISTOR

R2009	1-216-033-00	METAL GLAZE	220	5%	1/10W
R2010	1-216-033-00	METAL GLAZE	220	5%	1/10W
R2011	1-216-025-91	METAL GLAZE	100	5%	1/10W
R2012	1-216-089-91	METAL GLAZE	47K	5%	1/10W
R2013	1-216-105-91	METAL GLAZE	220K	5%	1/10W
R2014	1-216-033-00	METAL GLAZE	220	5%	1/10W
R2015	1-247-807-31	CARBON	100	5%	1/4W
R2016	1-216-133-00	METAL GLAZE	3.3M	5%	1/10W
					(KV-32V26)
R2059	1-216-047-91	METAL GLAZE	820	5%	1/10W
					(KV-32V26)
R2060	1-216-049-91	METAL GLAZE	1K	5%	1/10W
					(KV-32V26)
R2061	1-216-055-00	METAL GLAZE	1.8K	5%	1/10W
					(KV-32V26)
R2062	1-216-065-00	METAL GLAZE	4.7K	5%	1/10W
					(KV-32V26)
R2063	1-216-073-00	METAL GLAZE	10K	5%	1/10W
					(KV-32V26)
R2231	1-216-022-00	METAL GLAZE	75	5%	1/10W
					(KV-32V36/34V36C/35V36/35V76/37V36M)
R2232	1-216-022-00	METAL GLAZE	75	5%	1/10W
					(KV-32V36/34V36C/35V36/35V76/37V36M)
R2233	1-216-065-00	METAL GLAZE	4.7K	5%	1/10W
					(KV-32V36/34V36C/35V36/35V76/37V36M)
R2235	1-216-022-00	METAL GLAZE	75	5%	1/10W
R2236	1-216-113-00	METAL GLAZE	470K	5%	1/10W
R2237	1-216-065-00	METAL GLAZE	4.7K	5%	1/10W
R2238	1-216-113-00	METAL GLAZE	470K	5%	1/10W
R2239	1-216-065-00	METAL GLAZE	4.7K	5%	1/10W



Note: The components identified by shading and mark Δ are critical for safety. Replace only with part number specified.

Note: Les composants identifiés par un trame et une marque Δ sont critiques pour la sécurité. Ne les remplacer que par une pièce portant le numéro spécifié.

REF.NO.	PART NO.	DESCRIPTION	REMARK
S2001	1-692-431-21	SWITCH, TACTILE (KV-32V26)	
S2002	1-692-431-21	SWITCH, TACTILE (KV-32V26)	
S2003	1-692-431-21	SWITCH, TACTILE (KV-32V26)	
S2004	1-692-431-21	SWITCH, TACTILE (KV-32V26)	
S2005	1-692-431-21	SWITCH, TACTILE (KV-32V26)	
S2006	1-692-431-21	SWITCH, TACTILE (KV-32V26)	
S2007	1-692-431-21	SWITCH, TACTILE (KV-32V26)	



*A-1380-518-A MOUNTED PWB, K (KV-32V36/34V36C/35V76)

4-382-854-11 SCREW (M3X10), P, SW (+)

CAPACITOR

C1462	1-126-961-11	ELECT	2.2MF	20%	50V
C1463	1-126-961-11	ELECT	2.2MF	20%	50V
C1464	1-126-969-11	ELECT	220MF	20%	50V
C1465	1-104-664-11	ELECT	47MF	20%	25V
C1466	1-126-969-11	ELECT	220MF	20%	50V
C1467	1-126-961-11	ELECT	2.2MF	20%	50V
C1469	1-136-173-00	FILM	0.47MF	5%	50V
C1470	1-136-169-00	FILM	0.22MF	5%	50V
C1471	1-136-169-00	FILM	0.22MF	5%	50V
C1472	1-128-548-11	ELECT	4700MF	20%	25V
C1473	1-126-943-11	ELECT	2200MF	20%	25V
C1474	1-126-943-11	ELECT	2200MF	20%	25V
C1475	1-128-548-11	ELECT	4700MF	20%	25V
C1476	1-124-564-11	ELECT	4700MF	20%	25V

CONNECTOR

CN1461* 1-564-510-11 PLUG, CONNECTOR 7P
 CN1462* 1-564-507-11 PLUG, CONNECTOR 4P

DIODE

D1461 8-719-991-33 DIODE 1SS133T-77

IC

IC1461 8-759-980-43 IC TDA2009A

IC LINK

PS1461 Δ 1-532-984-11 LINK, IC 2A/90V

TRANSISTOR

Q1461 8-729-422-27 TRANSISTOR 2SD601A-Q
 Q1462 8-729-216-22 TRANSISTOR 2SA1162-G

REF.NO.	PART NO.	DESCRIPTION	REMARK
---------	----------	-------------	--------

RESISTOR

R1461	1-216-065-00	METAL GLAZE	4.7K	5%	1/10W
R1462	1-216-089-91	METAL GLAZE	47K	5%	1/10W
R1463	1-249-435-11	CARBON	33K	5%	1/4W
R1464	1-208-775-11	METAL GLAZE	510	0.50%	1/10W
R1465	1-216-011-00	METAL GLAZE	27	5%	1/10W
R1467	1-216-011-00	METAL GLAZE	27	5%	1/10W
R1468	1-208-775-11	METAL GLAZE	510	0.50%	1/10W
R1469	1-216-011-00	METAL GLAZE	27	5%	1/10W
R1471	1-216-011-00	METAL GLAZE	27	5%	1/10W
R1472	1-249-418-11	CARBON	1.2K	5%	1/4W F
R1473	1-249-413-11	CARBON	470	5%	1/4W
R1474	1-249-441-11	CARBON	100K	5%	1/4W
R1475	1-249-430-11	CARBON	12K	5%	1/4W
R1476	1-249-430-11	CARBON	12K	5%	1/4W
R1477	1-249-385-11	CARBON	2.2	5%	1/4W F
R1478	1-249-418-11	CARBON	1.2K	5%	1/4W F
R1479	1-249-385-11	CARBON	2.2	5%	1/4W F
R1480	1-249-421-11	CARBON	2.2K	5%	1/4W
R1481	1-249-421-11	CARBON	2.2K	5%	1/4W
R1482	1-249-421-11	CARBON	2.2K	5%	1/4W
R1483	1-249-421-11	CARBON	2.2K	5%	1/4W



* A-1390-585-A SC BOARD, MOUNTED

CONNECTOR

CN104 1-573-978-21 CONNECTOR, BOARD TO BOARD 11P
 CN105 1-573-978-21 CONNECTOR, BOARD TO BOARD 11P



*A-1394-844-A UV BOARD, COMPLETE (KV-32V26)
 *A-1394-846-A UV BOARD, COMPLETE (KV-35V36/35V76/34V36C)
 *A-1394-847-A UV BOARD, COMPLETE (KV-35V36/37V36M)

CAPACITOR

C151	1-126-960-11	ELECT	1MF	20%	50V
C152	1-126-960-11	ELECT	1MF	20%	50V
C153	1-164-489-11	CERAMIC CHIP	0.22MF	10%	16V
C154	1-164-489-11	CERAMIC CHIP	0.22MF	10%	16V
C156	1-164-182-11	CERAMIC CHIP	0.0033MF	10%	50V
C157	1-163-123-00	CERAMIC CHIP	180PF	5%	50V
C158	1-163-034-00	CERAMIC CHIP	0.033MF		50V
C159	1-163-017-00	CERAMIC CHIP	0.0047MF	10%	50V
C160	1-126-959-11	ELECT	0.47MF	20%	50V
C161	1-126-960-11	ELECT	1MF	20%	50V

Note: The components identified by shading and mark Δ are critical for safety. Replace only with part number specified.

Note: Les composants identifiés par un trame et une marque Δ sont critiques pour la sécurité. Ne les remplacer que par une pièce portant le numéro spécifié.

UV

REF.NO.	PART NO.	DESCRIPTION	REMARK
C162	1-126-960-11	ELECT	1MF 20% 50V
C163	1-165-319-11	CERAMIC CHIP	0.1MF 50V
C164	1-165-319-11	CERAMIC CHIP	0.1MF 50V
C165	1-165-319-11	CERAMIC CHIP	0.1MF 50V
C166	1-165-319-11	CERAMIC CHIP	0.1MF 50V
C167	1-126-933-11	ELECT	100MF 20% 16V
C168	1-126-964-11	ELECT	10MF 20% 50V
C170	1-163-123-00	CERAMIC CHIP	180PF 5% 50V
C231	1-163-031-11	CERAMIC CHIP	0.01MF 50V
C232	1-136-161-00	FILM	0.047MF 5% 50V
C233	1-136-161-00	FILM	0.047MF 5% 50V
C234	1-126-960-11	ELECT	1MF 20% 50V
C235	1-126-960-11	ELECT	1MF 20% 50V
C236	1-136-161-00	FILM	0.047MF 5% 50V
C237	1-126-960-11	ELECT	1MF 20% 50V
C238	1-126-960-11	ELECT	1MF 20% 50V
C241	1-126-941-11	ELECT	470MF 20% 25V
C242	1-126-959-11	ELECT	0.47MF 20% 50V
C244	1-126-959-11	ELECT	0.47MF 20% 50V
C245	1-126-941-11	ELECT	470MF 20% 25V (KV-32V36/34V36C/35V76)
C246	1-126-959-11	ELECT	0.47MF 20% 50V (KV-32V36/34V36C/35V76)
C247	1-126-959-11	ELECT	0.47MF 20% 50V (KV-32V36/34V36C/35V76)
C261	1-136-161-00	FILM	0.047MF 5% 50V (KV-35V36/37V36M/34V36C/32V36/35V76)
C262	1-104-664-11	ELECT	47MF 20% 25V
C263	1-136-161-00	FILM	0.047MF 5% 50V
C264	1-126-941-11	ELECT	470MF 20% 25V
C265	1-104-664-11	ELECT	47MF 20% 25V
C266	1-126-960-11	ELECT	1MF 20% 50V (KV-35V36/37V36M/34V36C/32V36/35V76)
C267	1-126-960-11	ELECT	1MF 20% 50V (KV-35V36/37V36M/34V36C/32V36/35V76)
C270	1-126-960-11	ELECT	1MF 20% 50V
C271	1-126-960-11	ELECT	1MF 20% 50V
C273	1-136-165-00	FILM	0.1MF 5% 50V
C274	1-163-031-11	CERAMIC CHIP	0.01MF 50V
C275	1-104-664-11	ELECT	47MF 20% 25V
C276	1-163-251-11	CERAMIC CHIP	100PF 5% 50V
C301	1-126-935-11	ELECT	470MF 20% 16V
C302	1-126-935-11	ELECT	470MF 20% 16V (KV-35V36/37V36M/34V36C/32V36/35V76)
<u>FILTER BLOCK</u>			
CM301	1-467-554-21	FILTER BLOCK, COMB	(KV-32V26)
CM302	1-467-656-11	FILTER BLOCK, COMB	(EXCEPT KV-32V26)

REF.NO.	PART NO.	DESCRIPTION	REMARK
<u>CONNECTOR</u>			
CN261	1-573-979-21	CONNECTOR, BOARD TO BOARD	11P
CN262	1-573-301-21	CONNECTOR, BOARD TO BOARD	20P
CN263*	1-564-506-11	PLUG, CONNECTOR	3P
CN264	1-573-979-21	CONNECTOR, BOARD TO BOARD	11P
<u>DIODE</u>			
D231	8-719-110-17	DIODE RD10ESB2	
D232	8-719-110-17	DIODE RD10ESB2	
D233	8-719-110-17	DIODE RD10ESB2	
D234	8-719-110-17	DIODE RD10ESB2	
D235	8-719-110-17	DIODE RD10ESB2	
D236	8-719-110-17	DIODE RD10ESB2	
D237	8-719-981-99	DIODE MTZJ-3.3	
D238	8-719-981-99	DIODE MTZJ-3.3	
D239	8-719-981-99	DIODE MTZJ-3.3	(KV-32V36/34V36C/35V76)
D240	8-719-110-17	DIODE RD10ESB2	
D241	8-719-110-17	DIODE RD10ESB2	
D242	8-719-110-17	DIODE RD10ESB2	
D243	8-719-110-17	DIODE RD10ESB2	
D244	8-719-110-17	DIODE RD10ESB2	
D245	8-719-981-99	DIODE MTZJ-3.3	(KV-32V36/34V36C/35V76)
D246	8-719-981-99	DIODE MTZJ-3.3	(KV-32V36/34V36C/35V76)
D264	8-719-110-17	DIODE RD10ESB2	
D265	8-719-110-17	DIODE RD10ESB2	
D902	8-719-921-54	DIODE MTZJ-6.2B	
<u>IC</u>			
IC151	8-759-700-44	IC NJM2902M	
IC152	8-759-700-44	IC NJM2902M	
IC153	8-759-100-96	IC UPC4558G2	
IC154	8-759-068-07	IC CD4052BCN	
IC261	8-759-366-78	IC MM1313AD	
<u>JACK</u>			
J231	1-750-515-11	TERMINAL BLOCK, S	3P
J232	1-750-517-11	JACK BLOCK, PIN	3P
J233	1-750-516-11	JACK BLOCK, PIN	2P
J234	1-750-517-11	JACK BLOCK, PIN	3P
J235	1-750-517-11	JACK BLOCK, PIN	3P (KV-34V36C/32V36/35V76)
J902	1-764-143-11	JACK	3P
J903	1-764-143-11	JACK	3P
J904	1-764-143-11	JACK	3P
<u>CHIP CONDUCTOR</u>			
JR151	1-216-295-91	CONDUCTOR, CHIP	(2012)
JR152	1-216-295-91	CONDUCTOR, CHIP	(2012)



Note: The components identified by shading and mark Δ are critical for safety. Replace only with part number specified.

Note: Les composants identifiés par un trame et une marque Δ sont critiques pour la sécurité. Ne les remplacer que par une pièce portant le numéro spécifié.

REF.NO.	PART NO.	DESCRIPTION	REMARK
JR201	1-216-295-91	CONDUCTOR, CHIP (2012)	
JR202	1-216-295-91	CONDUCTOR, CHIP (2012)	
JR204	1-216-295-91	CONDUCTOR, CHIP (2012)	
JR205	1-216-295-91	CONDUCTOR, CHIP (2012)	
JR206	1-216-295-91	CONDUCTOR, CHIP (2012)	
JR208	1-216-295-91	CONDUCTOR, CHIP (2012)	
JR209	1-216-295-91	CONDUCTOR, CHIP (2012)	
JR210	1-216-295-91	CONDUCTOR, CHIP (2012)	
JR211	1-216-295-91	CONDUCTOR, CHIP (2012)	
JR212	1-216-295-91	CONDUCTOR, CHIP (2012)	
JR213	1-216-295-91	CONDUCTOR, CHIP (2012)	
JR214	1-216-295-91	CONDUCTOR, CHIP (2012)	
JR215	1-216-295-91	CONDUCTOR, CHIP (2012)	
JR216	1-216-295-91	CONDUCTOR, CHIP (2012)	
JR217	1-216-295-91	CONDUCTOR, CHIP (2012)	
JR218	1-216-295-91	CONDUCTOR, CHIP (2012)	
JR219	1-216-295-91	CONDUCTOR, CHIP (2012)	
JR220	1-216-295-91	CONDUCTOR, CHIP (2012)	
JR221	1-216-295-91	CONDUCTOR, CHIP (2012)	
JR222	1-216-295-91	CONDUCTOR, CHIP (2012)	
JR223	1-216-295-91	CONDUCTOR, CHIP (2012)	
JR226	1-216-295-91	CONDUCTOR, CHIP (2012)	
JR228	1-216-295-91	CONDUCTOR, CHIP (2012)	
TRANSISTOR			
Q231	8-729-422-27	TRANSISTOR 2SD601A-Q	
Q232	8-729-422-27	TRANSISTOR 2SD601A-Q (KV-32V36/34V36C/35V76)	
Q233	8-729-422-27	TRANSISTOR 2SD601A-Q	
Q234	8-729-422-27	TRANSISTOR 2SD601A-Q	
Q235	8-729-422-27	TRANSISTOR 2SD601A-Q (KV-32V36/34V36C/35V76)	
Q236	8-729-422-27	TRANSISTOR 2SD601A-Q (KV-32V36/34V36C/35V76)	
Q237	8-729-216-22	TRANSISTOR 2SB709A-Q	
Q238	8-729-216-22	TRANSISTOR 2SB709A-Q	
Q239	8-729-216-22	TRANSISTOR 2SB709A-Q	
Q240	8-729-216-22	TRANSISTOR 2SB709A-Q (KV-32V36/34V36C/35V76)	
Q241	8-729-216-22	TRANSISTOR 2SB709A-Q (KV-32V36/34V36C/35V76)	
Q242	8-729-216-22	TRANSISTOR 2SB709A-Q (KV-32V36/34V36C/35V76)	
Q241	8-729-216-22	TRANSISTOR 2SB709A-Q (KV-32V36/34V36C/35V76)	
Q242	8-729-216-22	TRANSISTOR 2SB709A-Q (KV-32V36/34V36C/35V76)	
Q243	8-729-216-22	TRANSISTOR 2SB709A-Q	
Q261	8-729-422-27	TRANSISTOR 2SD601A-Q (EXCEPT KV-32V26)	
Q262	8-729-422-27	TRANSISTOR 2SD601A-Q	
Q263	8-729-216-22	TRANSISTOR 2SB709A-Q	
Q265	8-729-216-22	TRANSISTOR 2SB709A-Q	
RESISTOR			
R151	1-216-085-00	METAL GLAZE	33K 5% 1/10W
R152	1-216-075-00	METAL GLAZE	12K 5% 1/10W
R153	1-216-073-00	METAL GLAZE	10K 5% 1/10W

REF.NO.	PART NO.	DESCRIPTION	REMARK
R154	1-216-085-00	METAL GLAZE	33K 5% 1/10W
R155	1-216-075-00	METAL GLAZE	12K 5% 1/10W
R156	1-216-073-00	METAL GLAZE	10K 5% 1/10W
R157	1-216-079-00	METAL GLAZE	18K 5% 1/10W
R158	1-216-073-00	METAL GLAZE	10K 5% 1/10W
R159	1-216-073-00	METAL GLAZE	10K 5% 1/10W
R160	1-216-079-00	METAL GLAZE	18K 5% 1/10W
R161	1-216-073-00	METAL GLAZE	10K 5% 1/10W
R162	1-216-073-00	METAL GLAZE	10K 5% 1/10W
R163	1-216-073-00	METAL GLAZE	10K 5% 1/10W
R164	1-216-065-00	METAL GLAZE	4.7K 5% 1/10W
R165	1-216-073-00	METAL GLAZE	10K 5% 1/10W
R166	1-216-049-91	METAL GLAZE	1K 5% 1/10W
R167	1-216-065-00	METAL GLAZE	4.7K 5% 1/10W
R168	1-216-077-00	METAL GLAZE	15K 5% 1/10W
R169	1-216-099-00	METAL GLAZE	120K 5% 1/10W
R170	1-216-049-91	METAL GLAZE	1K 5% 1/10W
R171	1-216-049-91	METAL GLAZE	1K 5% 1/10W
R172	1-216-057-00	METAL GLAZE	2.2K 5% 1/10W
R173	1-216-065-00	METAL GLAZE	4.7K 5% 1/10W
R174	1-216-081-00	METAL GLAZE	22K 5% 1/10W
R175	1-216-081-00	METAL GLAZE	22K 5% 1/10W
R176	1-216-081-00	METAL GLAZE	22K 5% 1/10W
R177	1-216-049-91	METAL GLAZE	1K 5% 1/10W
R178	1-216-065-00	METAL GLAZE	4.7K 5% 1/10W
R179	1-216-065-00	METAL GLAZE	4.7K 5% 1/10W
R180	1-216-099-00	METAL GLAZE	120K 5% 1/10W
R181	1-216-049-91	METAL GLAZE	1K 5% 1/10W
R183	1-216-081-00	METAL GLAZE	22K 5% 1/10W
R184	1-216-081-00	METAL GLAZE	22K 5% 1/10W
R185	1-216-081-00	METAL GLAZE	22K 5% 1/10W
R186	1-216-089-91	METAL GLAZE	47K 5% 1/10W
R187	1-216-099-00	METAL GLAZE	120K 5% 1/10W
R188	1-216-097-91	METAL GLAZE	100K 5% 1/10W
R189	1-216-097-91	METAL GLAZE	100K 5% 1/10W
R190	1-216-081-00	METAL GLAZE	22K 5% 1/10W
R191	1-216-089-91	METAL GLAZE	47K 5% 1/10W
R192	1-216-063-91	METAL GLAZE	3.9K 5% 1/10W
R193	1-216-075-00	METAL GLAZE	12K 5% 1/10W
R194	1-216-099-00	METAL GLAZE	120K 5% 1/10W
R195	1-216-097-91	METAL GLAZE	47K 5% 1/10W
R196	1-216-089-91	METAL GLAZE	47K 5% 1/10W
R197	1-216-097-91	METAL GLAZE	100K 5% 1/10W
R198	1-216-081-00	METAL GLAZE	22K 5% 1/10W
R199	1-216-089-91	METAL GLAZE	47K 5% 1/10W
R200	1-216-081-00	METAL GLAZE	22K 5% 1/10W
R201	1-216-065-00	METAL GLAZE	4.7K 5% 1/10W
R202	1-216-049-91	METAL GLAZE	1K 5% 1/10W
R203	1-216-069-00	METAL GLAZE	6.8K 5% 1/10W

Note: The components identified by shading and mark Δ are critical for safety. Replace only with part number specified.

Note: Les composants identifiés par un trame et une marque Δ sont critiques pour la sécurité. Ne les remplacer que par une pièce portant le numéro spécifié.



REF.NO.	PART NO.	DESCRIPTION	REMARK
R204	1-216-069-00	METAL GLAZE	6.8K 5% 1/10W
R206	1-216-049-91	METAL GLAZE	1K 5% 1/10W (KV-32V36/34V36C/35V76)
R207	1-216-295-91	CONDUCTOR, CHIP (2012)	(KV-32V36/34V36C/35V76)
R208	1-216-049-91	METAL GLAZE	1K 5% 1/10W (KV-32V36/34V36C/35V76)
R209	1-216-069-00	METAL GLAZE	6.8K 5% 1/10W (KV-32V36/34V36C/35V76)
R210	1-216-069-00	METAL GLAZE	6.8K 5% 1/10W (32V36/34V36C/35V76)
R212	1-249-440-11	CARBON	82K 5% 1/4W
R213	1-216-065-00	METAL GLAZE	4.7K 5% 1/10W
R214	1-216-065-00	METAL GLAZE	4.7K 5% 1/10W
R215	1-249-413-11	CARBON	470 5% 1/4W
R216	1-216-025-91	METAL GLAZE	100 5% 1/10W
R217	1-216-025-91	METAL GLAZE	100 5% 1/10W
R218	1-216-025-91	METAL GLAZE	100 5% 1/10W
R219	1-216-065-00	METAL GLAZE	4.7K 5% 1/10W (32V36/34V36C/35V76)
R220	1-216-065-00	METAL GLAZE	4.7K 5% 1/10W (32V36/34V36C/35V76)
R221	1-249-413-11	CARBON	470 5% 1/4W (32V36/34V36C/35V76)
R222	1-216-025-91	METAL GLAZE	100 5% 1/10W (32V36/34V36C/35V76)
R223	1-216-025-91	METAL GLAZE	100 5% 1/10W (32V36/34V36C/35V76)
R224	1-216-025-91	METAL GLAZE	100 5% 1/10W (32V36/34V36C/35V76)
R225	1-247-815-91	CARBON	220 5% 1/4W
R226	1-247-815-91	CARBON	220 5% 1/4W
R227	1-249-440-11	CARBON	82K 5% 1/4W
R228	1-216-033-00	METAL GLAZE	220 5% 1/10W
R229	1-216-025-91	METAL GLAZE	100 5% 1/10W
R230	1-216-033-00	METAL GLAZE	220 5% 1/10W
R231	1-216-022-00	METAL GLAZE	75 5% 1/10W
R232	1-216-022-00	METAL GLAZE	75 5% 1/10W
R233	1-216-065-00	METAL GLAZE	4.7K 5% 1/10W
R234	1-216-022-00	METAL GLAZE	75 5% 1/10W
R235	1-216-113-00	METAL GLAZE	470K 5% 1/10W
R236	1-216-065-00	METAL GLAZE	4.7K 5% 1/10W
R237	1-216-113-00	METAL GLAZE	470K 5% 1/10W
R238	1-216-065-00	METAL GLAZE	4.7K 5% 1/10W
R239	1-216-022-00	METAL GLAZE	75 5% 1/10W
R240	1-216-113-00	METAL GLAZE	470K 5% 1/10W
R241	1-216-065-00	METAL GLAZE	4.7K 5% 1/10W
R242	1-216-113-00	METAL GLAZE	470K 5% 1/10W
R243	1-216-065-00	METAL GLAZE	4.7K 5% 1/10W
R244	1-216-113-00	METAL GLAZE	470K 5% 1/10W
R245	1-249-417-11	CARBON	1K 5% 1/4W

REF.NO.	PART NO.	DESCRIPTION	REMARK
R246	1-216-113-00	METAL GLAZE	470K 5% 1/10W
R247	1-249-417-11	CARBON	1K 5% 1/4W
R248	1-216-021-00	METAL GLAZE	68 5% 1/10W
R249	1-216-113-00	METAL GLAZE	470K 5% 1/10W
R250	1-216-113-00	METAL GLAZE	470K 5% 1/10W
R251	1-216-113-00	METAL GLAZE	470K 5% 1/10W
R252	1-216-019-00	METAL GLAZE	56 5% 1/10W (32V36/34V36C/35V76)
R253	1-216-113-00	METAL GLAZE	470K 5% 1/10W (32V36/34V36C/35V76)
R254	1-216-113-00	METAL GLAZE	470K 5% 1/10W (32V36/34V36C/35V76)
R255	1-216-113-00	METAL GLAZE	470K 5% 1/10W (32V36/34V36C/35V76)
R256	1-216-069-00	METAL GLAZE	6.8K 5% 1/10W
R258	1-216-069-00	METAL GLAZE	6.8K 5% 1/10W (32V36/34V36C/35V76)
R259	1-216-065-00	METAL GLAZE	4.7K 5% 1/10W
R260	1-247-807-31	CARBON	100 5% 1/4W
R261	1-216-009-00	METAL GLAZE	22 5% 1/10W
R264	1-247-815-91	CARBON	220 5% 1/4W
R265	1-247-815-91	CARBON	220 5% 1/4W
R266	1-216-043-91	METAL GLAZE	560 5% 1/10W (EXCEPT KV-32V26)
R267	1-249-415-11	CARBON	680 5% 1/4W (EXCEPT KV-32V26)
R268	1-216-025-91	METAL GLAZE	100 5% 1/10W
R269	1-216-025-91	METAL GLAZE	100 5% 1/10W
R270	1-216-041-00	METAL GLAZE	470 5% 1/10W
R271	1-249-415-11	CARBON	680 5% 1/4W
R272	1-249-417-11	CARBON	1K 5% 1/4W
R274	1-249-413-11	CARBON	470 5% 1/4W
R275	1-249-425-11	CARBON	4.7K 5% 1/4W (EXCEPT KV-32V26)
R276	1-249-425-11	CARBON	4.7K 5% 1/4W (EXCEPT KV-32V26)
R277	1-216-049-91	METAL GLAZE	1K 5% 1/10W
R278	1-249-413-11	CARBON	470 5% 1/4W (KV-32V36/34V36C/35V76)
R279	1-216-025-91	METAL GLAZE	100 5% 1/10W
R280	1-216-033-00	METAL GLAZE	220 5% 1/10W
R281	1-216-033-00	METAL GLAZE	220 5% 1/10W
R282	1-216-025-91	METAL GLAZE	100 5% 1/10W
R283	1-216-025-91	METAL GLAZE	100 5% 1/10W
R284	1-216-065-00	METAL GLAZE	4.7K 5% 1/10W
R285	1-216-065-00	METAL GLAZE	4.7K 5% 1/10W
R286	1-216-049-91	METAL GLAZE	1K 5% 1/10W
R288	1-247-815-91	CARBON	220 5% 1/4W
R289	1-247-815-91	CARBON	220 5% 1/4W
R290	1-247-815-91	CARBON	220 5% 1/4W
R291	1-216-025-91	METAL GLAZE	100 5% 1/10W



Note: The components identified by shading and mark Δ are critical for safety. Replace only with part number specified.

Note: Les composants identifiés par un trame et une marque Δ sont critiques pour la sécurité. Ne les remplacer que par une pièce portant le numéro spécifié.

REF.NO.	PART NO.	DESCRIPTION	REMARK
R293	1-216-025-91	METAL GLAZE	100 5% 1/10W
R294	1-216-049-91	METAL GLAZE	1K 5% 1/10W
R301	1-249-417-11	CARBON	1K 5% 1/4W
R304	1-249-417-11	CARBON	1K 5% 1/4W
R902	1-249-405-11	CARBON	100 5% 1/4W F
R919	1-216-295-91	CONDUCTOR,CHIP (2012)	
R920	1-249-405-11	CARBON	100 5% 1/4W F
R921	1-249-405-11	CARBON	100 5% 1/4W F
R922	1-216-049-91	METAL GLAZE	1K 5% 1/10W
R923	1-216-049-91	METAL GLAZE	1K 5% 1/10W
R924	1-216-049-91	METAL GLAZE	1K 5% 1/10W
R925	1-215-433-00	METAL	3.3K 1% 1/4W
R926	1-215-433-00	METAL	3.3K 1% 1/4W
R1151	1-216-053-00	METAL GLAZE	1.5K 5% 1/10W
R1152	1-216-049-91	METAL GLAZE	1K 5% 1/10W
R1153	1-216-089-91	METAL GLAZE	47K 5% 1/10W
R1154	1-216-049-91	METAL GLAZE	1K 5% 1/10W
R1155	1-216-089-91	METAL GLAZE	47K 5% 1/10W
R1156	1-216-073-00	METAL GLAZE	10K 5% 1/10W
R1157	1-216-073-00	METAL GLAZE	10K 5% 1/10W
R1158	1-216-065-00	METAL GLAZE	4.7K 5% 1/10W
R1159	1-216-065-00	METAL GLAZE	4.7K 5% 1/10W
R1160	1-216-295-91	CONDUCTOR,CHIP (2012)	
R1161	1-216-295-91	CONDUCTOR,CHIP (2012)	
R1164	1-216-049-91	METAL GLAZE	1K 5% 1/10W
R1165	1-216-049-91	METAL GLAZE	1K 5% 1/10W
R1166	1-216-049-91	METAL GLAZE	1K 5% 1/10W
R1167	1-216-049-91	METAL GLAZE	1K 5% 1/10W
R1168	1-21 6-049-91	METAL GLAZE	1K 5% 1/10W

MISCELLANEOUS

KV-32V26/32V36/34V36C ONLY

Δ	1-411-474-11	COIL, DEMAGNETIC (KV-34V36C)
Δ	1-411-952-11	COIL, DEMAGNETIC (KV-32V26/32V36)
	1-452-579-21	MAGNET, DISC (KV-32V26/32V36/34V36C)
Δ	1-452-579-21	NECK ASSY, CRT (NA322) (KV-34V36C)
	1-473-549-11	SWITCH BLOCK, CONTROL (EXCEPT KV-32V26)
	1-504-524-11	SPEAKER (8CM) (KV-32V26)
	1-505-326-11	SPEAKER (8CM) (KV-32V36/34V36C)
*	1-557-056-31	CABLE P-P (KV-32V36/34V36C)
*	1-556-945-21	CABLE P-P (KV-32V36/34V36C)
Δ	1-751-059-11	CORD, POWER (WITH CONNECTOR) (KV-34V36C)
	1-776-374-11	PLUG, F-PIN (KV-32V26)
Δ	8-451-482-11	DEFLECTION YOKE (Y34FXA2-X) (KV-32V26/32V36/34V36C)
	8-598-414-00	ANTENNA SWITCH (KV-32V26/34V36C)
Δ	8-733-745-05	CRT 34FXD2 (SPD) (XBR) (KV-32V26/32V36/34V36C)
	1-900-800-81	WIRE ASSY, G2 LEAD (KV-32V26)
	1-900-800-82	WIRE ASSY, FOCUS (KV-32V36)

REF.NO.	PART NO.	DESCRIPTION	REMARK
KV-35V36/35V76/37V36M ONLY			
Δ	1-411-881-11	COIL, DEMAGNETIC (KV-35V36/35V76/37V36M)	
Δ	1-411-882-11	COIL, DEMAGNETIC (KV-35V36/35V76/37V36M)	
	1-473-549-11	SWITCH BLOCK, CONTROL (KV-35V36/35V76/37V36M)	
	1-556-945-21	CABLE P-P	
	1-557-056-31	CABLE P-P (KV-35V36/35V76/37V36M)	
Δ	1-751-059-11	CORD, POWER (WITH CONNECTOR) (KV-35V36/35V76/37V36M)	
	8-453-007-11	NA324-M (KV-35V36/35V76/37V36M)	
	8-598-414-00	ANTENNA SWITCH (KV-35V36/35V76/37V36M)	
Δ	8-733-760-71	ITC 37GX-A1 (KV-35V36/35V76/37V36M)	

ACCESSORIES AND PACKING MATERIALS

3-701-627-00	BAG, POLYETHYLENE
3-859-518-21	MANUAL INSTRUCTION

KV-32V26/32V36/34V36C ONLY

*	4-049-758-11	BAG, PROTECTION (KV-32V26/32V36/34V36C)
*	4-054-067-01	CUSHION (UPPER ASSY) (KV-32V26/32V36/34V36C)
*	4-054-070-01	CUSHION (LOWER, ASSY) (KV-32V26/32V36/34V36C)
*	4-054-073-01	INDIVIDUAL CARTON (KV-32V26/32V36/34V36C)
*	4-054-074-01	INDIVIDUAL CARTON (KV-32V26/32V36/34V36C)

KV-35V76 ONLY

	2-352-981-01	SPACER (KV-35V76)
	2-359-505-01	RETAINER, MAGNET (KV-35V76)
*	4-030-895-01	JOINT (KV-35V76)
	4-041-162-01	PIN RACK (KV-35V76)
	4-041-362-01	HINGE SET (KV-35V76)
*	4-041-423-01	SHEET PROTECTION (KV-35V76)
*	4-041-425-01	BAG, PROTECTION (KV-35V76)
*	4-052-910-01	CUSHION (UPPER ASSY) (KV-35V76)
*	4-052-911-01	TRAY (KV-35V76)
*	4-052-914-01	INDIVIDUAL CARTON (KV-35V76)
*	4-053-277-01	CUSHION (LOWER, ASSY) (KV-35V76)
	4-054-376-01	WASHER (4) (KV-35V76)
	4-054-426-01	CUSHION (FRONT) (KV-35V76)
	4-055-014-01	SPACER (KV-35V76)
	4-055-138-01	SHEET FRONT (KV-35V76)
	4-838-438-00	LATCH (KV-35V76)

KV-35V36/37V36M ONLY

*	4-053-658-01	BAG, PROTECTION (KV-35V36/37V36M)
*	4-053-276-01	INDIVIDUAL CARTON (KV-35V36/37V36M)
*	4-053-277-01	CUSHION (UPPER ASSY) (KV-35V36/37V36M)
*	4-053-278-01	CUSHION (LOWER, ASSY) (KV-35V36/37V36M)

REMOTE COMMANDER

1-473-750-41	REMOTE COMMANDER RM-Y137A
4-978-977-01	LID, BATTERY COVER (FOR RM-Y137A)

9-965-827-01

Sony Corporation
Sony Technology Center
Product Quality Division
Service Promotion Department

English
97DJ74395-1
Printed in U.S.A.
© 1997.4